

IT 1900

2D-code hand-held scanner

en 01-2011/04 50115720

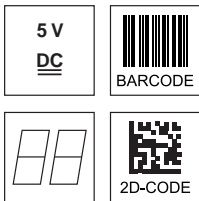

- Hand-held scanner for Data-Matrix Codes and Bar Codes
- Large reading field for the detection of high-contrast codes
- Robust trigger button
- Built-in decoder
- Read-display
- RS 232, USB and PS/2 interface
- Operating temperature from 0 through 50°C
- Larger reading field through higher resolution and improved decoding



We reserve the right to make changes • PAL_IT1900_en.fm

Accessories

- **RS 232 cable**
part no. 50115105
- **TTL-RS 232 cable**
part no. 50114517
- **PS/2 cable**
part no. 50114519
- **USB cable, 3m**
part no. 50114521
- **USB helix cable, 5m**
part no. 50114523
- **Power supply unit**
part no. 50114525

Dimensioned drawing

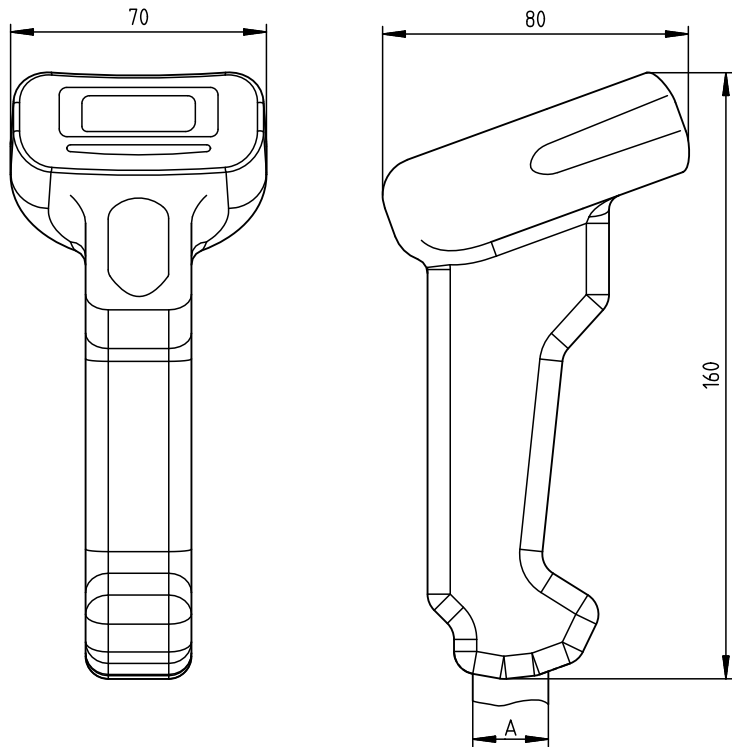

A Cable entry:
depending on the cable, max. Ø 20mm,
cable-Ø 5mm

Electrical connection

for RS 232 cable

9-pin Sub-D	Signal	Connection for power supply unit	IT 1900 RJ41
2	TXD		4
3	RXD		5
5	GND	external	3
7	CTS		6
8	RTS		8
9	5VDC	internal	7

for USB cable

USB type A	Signal	IT 1900 RJ41
1	5VDC	7
2	Data -	10
3	Data +	9
4	GND	3

for PS/2 cable

Mini DIN connector	Mini DIN socket	Signal	IT 1900 RJ41
1	-	PC Data	4
2	2	NC	
3	3	GND	3
4	4	5VDC	7
5	-	PC Clock	5
6	6	NC	
-	1	KB Data	8
-	5	KB Clock	6

Specifications

Electrical data

Operating voltage U_B 4 ... 5.5VDC
 Power consumption max. 2,3W

Interfaces

Interface type RS 232, PS/2 and USB
 Trigger via button or serial command

Code types

2D codes Data Matrix ECC 200, MaxiCode, PDF417, MicroPDF, QR Code, Aztec, Aztec Mesas, Code 49, EAN/UCC Composite
 Bar codes 2/5 Interleaved, Code 39, Code 128, Code 93, Codabar, UPC/EAN, Codablock, GS1 Databar

Optical data

Optical system high-resolution pixel array 838x640
 Symbol contrast PCS 20% minimum
 Light source integrated diffuse LED, wavelength 617nm \pm 18nm
 Read direction omnidirectional, various tilt and rotational angles up to 45°

Mechanical data

Weight 147g (without cable)
 Dimensions 104x71x160mm
 Shock resistance 50 falls from a height of 1.8m

Environmental data

Ambient temp. (operation/storage) 0°C ... +50°C/-40°C ... +70°C
 Relative air humidity 0 ... 95% (non-condensing)
 Protection class IP 41

Tables

Diagrams

Reading field

IT 1900g HD-2

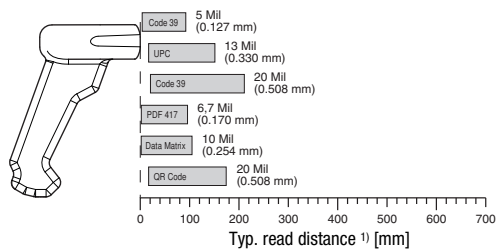

IT 1900g SR-2

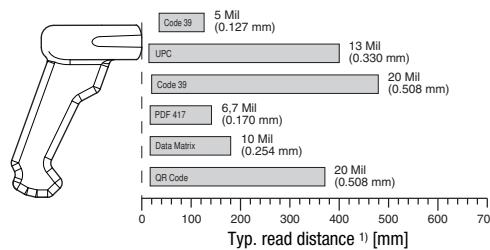

IT 1900g ER-2

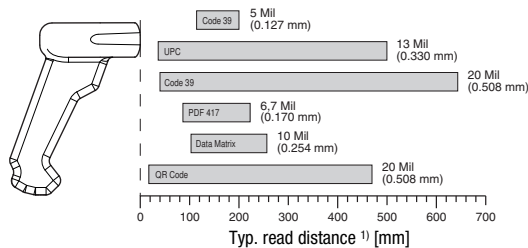

1) Dependent on code module

Order guide

2D code hand-held scanner (special optics for very small codes)

IT 1900g HD-2 with RS 232, PS/2 and USB interface

Part No.

50114507

2D-code hand-held scanner (standard range)

IT 1900g SR-2 with RS 232, PS/2 and USB interface

Part No.

50114509

2D code hand-held scanner (special optics with large range)

IT 1900g ER-2 with RS 232, PS/2 and USB interface

Part No.

50114504

Remarks

Ergonomically shaped hand-held scanner with integrated decoder for high-contrast codes.

Data transmission via configurable RS 232 interface.

Or keyboard-wedge operation via PS/2 or USB interface.

Switching off the computer

Information on switching off and shutting down the connected computer - which must always be performed before connecting peripheral devices, such as a scanner - can be found in the appropriate operating instructions for your computer.

Connecting the IT 1900

Shown in the adjacent figure is the location of the cable connection and trigger button of the scanner. The individual steps for installing the cable on the scanner are described below.

1. To secure the interface cable to the scanner, proceed as follows:
Insert the RJ 41 connector into the socket on the bottom of the hand-held scanner until the connector engages.
Connect the interface cable to the appropriate connection socket on the computer.
2. You may need a power supply unit for supplying voltage; alternatively, you can use a cable which supplies voltage from the computer system. Use the pin assignments (see "Electrical connection" on page 1) to select the appropriate cable for your application.
3. Connect the power supply unit to the power socket (not necessary if voltage is supplied from the computer).
4. Check the operational readiness of the scanner by pointing the scanning surface towards a flat surface and pulling the trigger. A red target line as well as the red illumination should now be visible. Now scan a sample label.
The scanner emits an audible signal to confirm that the label has been read; if necessary, the data are now passed on to the computer.

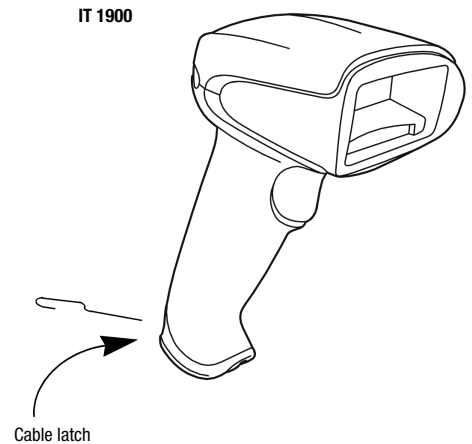

Configuration

The hand-held scanner can always be configured using bar codes. To do this, the barcode must first be selected on the package insert and then the trigger actuated in order to read the code. The configuration is then immediately accepted and executed.

Several of the most important configurations are listed in the following.

A second option is to configure the hand-held scanner with the USB and RS232 interfaces with the aid of the **EZ Config** PC program. You can download and install this program from our homepage at www.leuze.de.

The program can be used to make settings and transfer them to the hand-held scanner. The configuration can also be stored so that it can be reused at a later time.

Further information on this can be found in the User's Guide for the IT 1900/1902.

The standard applications are described and summarised below.



Notice!

Additional information on the device and short instructions can be found on the Internet at www.leuze.de.

Resetting the IT 1900 to factory settings

To reset all parameters to factory settings, scan the adjacent barcode.



Attention!

All settings are lost!!!



Trigger

To activate the read process, a trigger signal is to be sent via the serial RS 232 interface or USB interface (COM port emulation only). The command is to be sent at the set baud rate, parity, and data and stop bits.

The command for activation is: **SYN T CR** ASCII decimal values: 022; 084; 013

To cancel read readiness, send a deactivation.

The command for deactivation is: **SYN U CR** ASCII decimal values: 022; 085; 013

Following a successful read operation, the IT 1900 deactivates itself.

The second option is activation via the built-in trigger button.

Configuration for the Leuze standard protocol

Scan the adjacent 2D code.

The IT 1900 is set to the following transmission parameters:

RS 232 transmission with 9,600 baud, 8 data bits, 1 stop bit, no parity, prefix <STX>, terminators <CR><LF>.



IT 1900

2D-code hand-held scanner

Connecting the IT 1900 to the serial PC interface

With voltage supply via PIN 9 for RS232 cable (part. no. 50114517)

required parts:

- 1x IT 1900g XX-2
- 1x 50114517 KB 232-1 IT190x

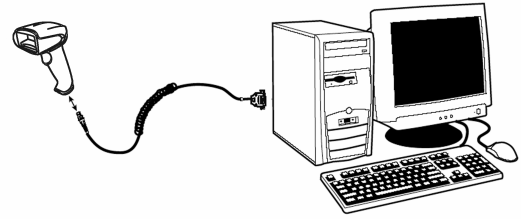

With voltage supply via power supply unit with cable RS232 (part no. 50114517)

required parts:

- 1x IT 1900g XX-2
- 1x 50114517 KB 232-1 IT190x
- 1x 50114525 Power supply unit

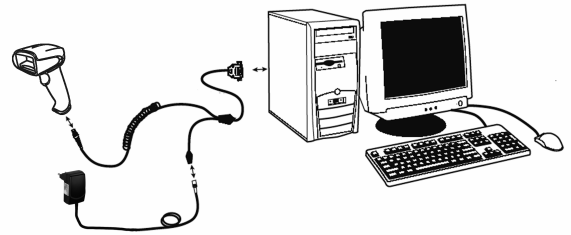

Notice!

The **KB 232-1 IT190x** cable (part. no. 50114517) uses TTL level (0V...5V) for data transmission. Alternatively, the **KB 232-2 IT190x** cable (part. no. 50115105) can be used which works with the regular RS232 level (-12V...+12V) and therefore features a higher interference rejection. Both cables are connection compatible.

Procedure:

1. Switch off the PC.
2. Connect the interface cable to a free COM port (RS 232) on the computer, to the IT 1900 as well as to the power supply unit (if present).
3. Switch the PC back on.
4. Scan the adjacent barcode.
The IT 1900 is set to the following transmission parameters:
RS 232 transmission with 115,200 baud, 8 data bits, 1 stop bit, no parity, terminators <CR><LF>.
5. If necessary, adjust the transmission parameters of the used COM port to those of the IT 1900.



Attention!

We recommend connecting the IT 1900 directly to a PC or to the MA 21 or MA 41... connector units. If connecting to other components, please note that the voltage level range is maintained on the data lines!

Connecting the IT 1900 to the MA 41 DP-K or MA 41 IS

required parts:

1x	IT 1900g XX-2	
1x	50114517 KB 232-1 IT190x	
1x	50114525 Power supply unit	
1x	50035421 KB 021 Z	
1x	50033638 MA 41 DP-K for Profibus (for Interbus: or	50028994 MA 41 IS 50030085 MA 41 IS PDP)

Pin assignments KB 021 Z:

Core colour:	signal	terminal in the MA 41:
brown	(RXD)	2
white	(TXD)	1
blue	(GND)	4
red	(VCC)	⊗
black	(GND)	⊗
bare (shield)	(PE)	21

Procedure:

1. Connect cable KB 021 Z to the MA 41... acc. to the above pin assignments.
2. Connect the interface cable to cable KB 021 Z.
3. Scan the adjacent 2D code.
The IT 1900 is set to the following transmission parameters:
RS 232 transmission with 9600 baud, 8 data bits, 1 stop bit, no parity, terminators <CR><LF>.



Connecting the IT 1900 to the MA 21

required parts:

1x	IT 1900g XX-2
1x	50114517 KB 232-1 IT190x
1x	50035421 KB 021 Z
1x	50030481 MA 21 100

Pin assignments KB021 Z:

Core colour:	signal	terminal in the MA 21:
brown	(RXD)	26
white	(TXD)	27
blue	(GND)	28
red	(VCC)	30
black	(GND)	31
bare (shield)	(PE)	21

Procedure:

1. Connect cable KB 021 Z to the MA 21... acc. to the above pin assignments.
2. Connect the interface cable to cable KB 021 Z.
3. Scan the adjacent 2D code.
The IT 1900 is set to the following transmission parameters:
RS 232 transmission with 9600 baud, 7 data bits, 1 stop bit, even parity, terminators <CR><LF>.



IT 1900

2D-code hand-held scanner

Connecting the IT 1900 to the MA 2xxi

required parts:

1x	IT 1900g XX-2
1x	50114517 KB 232-1 IT190x
1x	50113397 KB JST-HS-300
1x	MA 2xxi for the respective fieldbus system

Procedure:

1. Connect the KB JST-HS-300 cable to the system connectors in the MA 2xxi.
2. Connect the interface cable to cable KB JST-HS-300.
3. Scan the adjacent 2D code. The IT 1900 is set to the following transmission parameters:
RS 232 transmission with 9600 baud, 8 data bits, 1 stop bit, no parity, terminators
<CR><LF>.



Connecting the IT 1900 to the PS/2 interface

The operation of the IT 1900 in keyboard emulation mode is described in this section. A PC keyboard is emulated in this operating mode. The data which are read in are written directly to the currently activated program. Thus, the data can be processed further in all standard programs.

required parts:

1x	IT 1900g XX-2
1x	50114519 KB PS2-1 IT190x

Procedure:

1. Switch off the PC.
2. Disconnect the keyboard.
3. Plug in the IT 1900 hand-held scanner between the keyboard and the PC.
4. Switch the PC back on.
5. Scan the 2D code shown below.

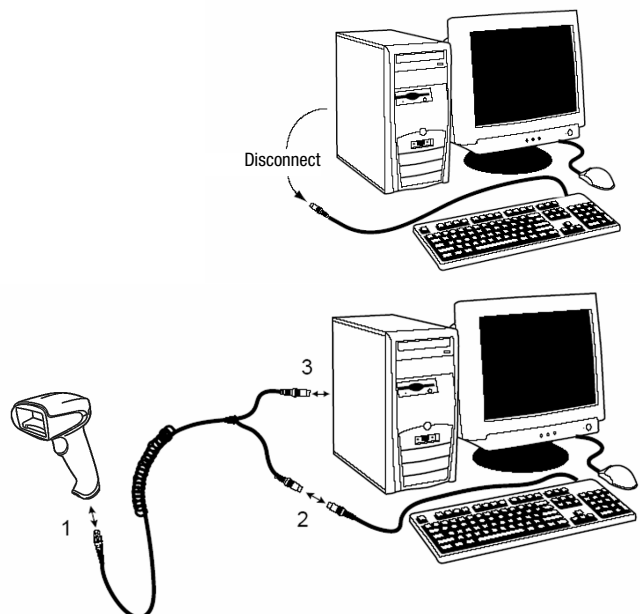

Connecting the IT 1900 to the USB interface (keyboard emulation)

The operation of the IT 1900 in keyboard-emulation mode on a USB port is described in this section. A PC keyboard is emulated in this operating mode. The data which are read in are written directly to the currently activated program. Thus, the data can be processed further in all standard programs.

required parts:

- 1x IT 1900g XX-2
- 1x 50114521 KB USB-1 IT190x (3m, straight)
- or
- 1x 50114523 KB USB-2 IT190x (5m, spiral)

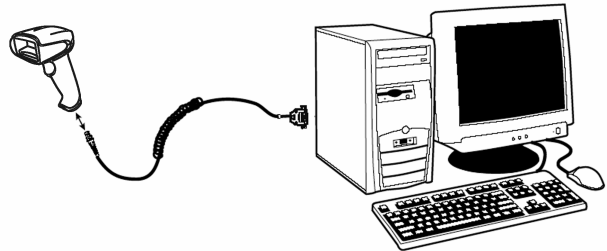

Procedure:

1. Plug the IT 1900 hand-held scanner into a free USB port.
2. The scanner acknowledges this connection with a beep.
3. Scan the adjacent 2D code.



Connecting the IT 1900 to the USB interface (COM-port emulation)

The operation of the IT 1900 as a serial interface on a USB port is described in this chapter. A COM interface is emulated in this operating mode. The data which are read in are sent to a new COM interface. The driver with which you emulate this COM interface can be downloaded from our homepage at www.leuze.de. Thus, the data can be processed further in programs which expect data via COM interfaces.

required parts:

- 1x IT 1900g XX-2
- 1x 50114521 KB USB-1 IT190x (3m, straight)
- or
- 1x 50114523 KB USB-2 IT190x (5m, spiral)

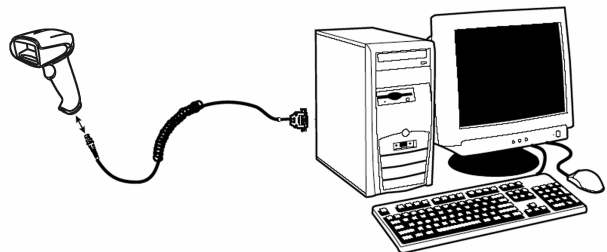

Procedure:

1. Install the USB serial driver
(current version at www.leuze.com).
2. Plug the IT 1900 hand-held scanner into a free USB port.
3. The scanner acknowledges this connection with a beep.
4. Scan the adjacent 2D code.
5. Open a terminal program or your program for the serial interface, select the new COM port, and make the following settings: baud rate 38,400, 8 data bits, 1 stop bit, no parity, terminator <CR>.

