



MSI-i/R

Modular Safety Interface



Notes on connection and operating instructions

These connecting and operating instructions contain information on the proper use of MSI Safety Interfaces in accordance with its intended purpose.



All the information contained herein, in particular the safety notes, need to be carefully observed.

Notes regarding safety and warnings are marked by this symbol



These connecting and operating instructions must be stored carefully. It must be available for the entire operating time of the MSI Safety Interfaces.

The Leuze electronic GmbH + Co. KG is not liable for damages caused by improper use. Acquaintance with these instructions is an element of the knowledge required for proper use.

© Reprint and reproduction, in whole or in part, only with the explicit permission from:

Leuze electronic GmbH + Co. KG
In der Braike 1
D-73277 Owen - Teck / Germany
Telefon +49 (0) 7021 / 573-0
Fax +49 (0) 7021 / 573-199
info@leuze.de
www.leuze.com

Table of contents

1	System Overview and Range of Applications	4	3.3.1.3	Operating Mode: With Start/Restart Interlock – Without External Device Monitoring	17
1.1	General Information	4	3.3.1.4	Operating Mode: Without Start/Restart Interlock – Without External Device Monitoring	17
1.2	Approvals	4	3.3.1.5	Operating Mode: With Start/Without Restart Interlock – Without External Device Monitoring	18
1.3	Terminology	5	3.3.2	Guard Operation, Test Function	18
1.4	Nomenclature MSI-i/R	6	3.3.3	Cyclical Operation as Single Break or Double Break with Guard Function	18
2	Safety	7	3.3.4	Cycling operation, Diagram	20
2.1	Approved purpose and foreseeable improper operation	7	3.4	Displays	22
2.1.1	Proper use	8	3.5	Status Outputs	23
2.1.2	Foreseeable misuse	10	3.6	Diagnosis Function	24
2.2	Competent personnel	10	4	Electrical Connection	26
2.3	Responsibility for safety	10	4.1	Installation Regulations	26
2.4	Exemption of liability	11	4.2	Power Supply Requirements	26
2.5	EMERGENCY STOP button to be connected	12	4.3	Connecting AOPDs, Type 4 or Type 2	26
2.6	Additional Safety Precautions for the Special Function "Cyclical Control"	12	4.4	Connecting Machine Controls	29
3.1	System Configuration	13	6.1	MSI-i/R	32
3.2	DIP Switch Settings	13	6.2	/R-Output	34
3.2.1	DIP Switch Settings for the MSI-i Module	13	6.3	Dimensional Drawing	35
3.3	Operating Modes and Functions	14	6.4	Ordering Information	36
3.3.1	Operating Modes Interlocking Functions and External Device Monitoring	15	7	EC Declaration of Conformity	37
3.3.1.1	Operating Mode: With Start/Restart Interlock – With Dynamic External Device Monitoring	16			
3.3.1.2	Operating Mode: With Start/Restart Interlock – With Static External Device Monitoring	16			

1 System Overview and Range of Applications

1.1 General Information

The Modular Safety Interface (MSI) serves as a link between one or more active optoelectronic protective devices (AOPD), Type 2, Type 3 or Type 4, and the machine controls. All MSI safety components include start/restart interlock and external device monitoring functions that can be activated and deactivated. They are also equipped with a series of status outputs and LED displays as well as a diagnosis interface to a PC.

In addition, MSI-i/R offers a selection between guard only operation and cyclical operation. During cyclical operation, the machine is controlled by means of the interruption and subsequent release of the protected

field. It is also possible to use the muting function to suppress the protective function of an AOPD, e.g. during the return motion of the tool, if no danger is caused by this movement. Special safety regulations for cyclical operation are described in Chapter 2.6 below.

Leuze electronic offers a number of other MSI safety modules with standard or special functions, such as muting (intended suppression of the safety function, e.g. during material transport through the protective field).

All MSI safety modules are equipped with relay outputs.

1.2 Approvals

Europe
EC Type Examination DIN EN ISO 13849-1/2 GS-ET-20 "Safety relays" IFA Institut für Arbeitsschutz der Deutschen Gesetzlichen Unfallversicherung D-53757 Sankt Augustin

1.3 Terminology

AOPD	Active Optoelectronic Protective Device
Clear	Clearance of Cycles, Test
Diagn.	Diagnosis Function
EDM	External Device Monitoring
ESPE	Electro-sensitive Protecting Equipment
Fault	Relay Fault
Locked	Start/Restart Interlock active
N.O.	Normal Open Contact
OSSD	Safety-related switching output
Reset	Start/Restart Interlock Initiator
RS 232	Interface RS 232
S1 - S2	Safety input 1 - 2
S1 & S2	Indication protected fields free/interrupted
Select	Selection of Cycling Operation
Test	Test Signal Outputs
T1, T2	Test signal output 1, 2

1.4 Nomenclature MSI-i/R

MSI	Modular Safety Interface
i	with modes of operation Guard only, Single break or Double break This version offers the following standard functions for either 1 AOPD, Type 4, or up to 2 AOPDs, Type 2: – Start/restart interlock – External device monitoring – Diagnosis function and the following special functions for 1 AOPD Type 4 or 1AOPD Type 2: – Cyclical operation – Displays and status outputs for guard, cyclical and muting operation
/R	Relay output: – two normal open safety contacts, OSSD 1 and OSSD 2

2 Safety

Before using the Safety Interface Device, a risk evaluation must be performed according to valid standards (e.g. ISO 14121, EN ISO 12100-1, ISO 13849-1, EN 62061). The result of the risk assessment determines the required safety level of the Safety Interface Device (see table in chapter 2.1.1). For mounting, operating and testing, document "MSI-i/R Modular Safety Interface Device" as well as all applicable national and international standards, regulations, rules and directives must be observed. Relevant and supplied documents must be observed, printed out and handed to the affected personnel.

Before working with the Safety Interface Device, completely read and understand the documents applicable to your task.

In particular, the following national and international legal regulations apply for the start-up, technical inspections and work with safety sensors:

- Machinery directive 2006/42/EC

2.1 Approved purpose and foreseeable improper operation



Warning!

A running machine can cause severe injuries!

- Low Voltage Directive 2006/95/EC
- Electromagnetic compatibility directive 2004/108/EC
- Use of Work Equipment Directive 89/655/EEC supplemented by Directive 95/63 EC
- OSHA 1910 Subpart O
- Safety regulations
- Accident-prevention regulations and safety rules
- Ordinance on Industrial Safety and Health and Labor Protection Act
- Device Safety Act



For safety-related information you may also contact the local authorities (e.g., industrial inspectorate, employer's liability insurance association, labor inspectorate, occupational safety and health authority).

Make certain that, during all conversions, maintenance work and inspections, the system is securely shut down and protected against being restarted again.

2.1.1 Proper use

The Safety Interface Device must only be used after it has been selected in accordance with the respectively applicable instructions and relevant standards, rules and regulations regarding labor protection and occupational safety, and after it has been installed on the machine, connected, commissioned, and checked by a competent person.

- When selecting the Safety Interface Device it must be ensured that its safety-related capability meets or exceeds the required performance level PLr ascertained in the risk assessment.

The following table shows the safety-related characteristic parameters of the MSI-i/R modular Safety Interface Devices.

Type in accordance with DIN EN IEC 61496-1	Type 4												
SIL in accordance with IEC 61508	SIL 3												
Performance Level (PL) in accordance with DIN EN ISO 13849-1	PL e												
Category in accordance with DIN EN ISO 13849-1	Cat. 4												
Mean probability of a dangerous failure per hour (PFH _d) as a function of the mean number of annual switching cycles of the relay n _{op} *	<table> <tr> <td>100% Load n_{op} = 4.800:</td> <td>1,5 x 10⁻⁰⁸ 1/h</td> </tr> <tr> <td>60% Load n_{op} = 4.800:</td> <td>1,2 x 10⁻⁰⁸ 1/h</td> </tr> <tr> <td>100% Load n_{op} = 28.800:</td> <td>3,1 x 10⁻⁰⁸ 1/h</td> </tr> <tr> <td>60% Load n_{op} = 28.800:</td> <td>1,5 x 10⁻⁰⁸ 1/h</td> </tr> <tr> <td>100% Load n_{op} = 86.400:</td> <td>7,4 x 10⁻⁰⁸ 1/h</td> </tr> <tr> <td>60% Load n_{op} = 86.400:</td> <td>2,1 x 10⁻⁰⁸ 1/h</td> </tr> </table>	100% Load n _{op} = 4.800:	1,5 x 10 ⁻⁰⁸ 1/h	60% Load n _{op} = 4.800:	1,2 x 10 ⁻⁰⁸ 1/h	100% Load n _{op} = 28.800:	3,1 x 10 ⁻⁰⁸ 1/h	60% Load n _{op} = 28.800:	1,5 x 10 ⁻⁰⁸ 1/h	100% Load n _{op} = 86.400:	7,4 x 10 ⁻⁰⁸ 1/h	60% Load n _{op} = 86.400:	2,1 x 10 ⁻⁰⁸ 1/h
100% Load n _{op} = 4.800:	1,5 x 10 ⁻⁰⁸ 1/h												
60% Load n _{op} = 4.800:	1,2 x 10 ⁻⁰⁸ 1/h												
100% Load n _{op} = 28.800:	3,1 x 10 ⁻⁰⁸ 1/h												
60% Load n _{op} = 28.800:	1,5 x 10 ⁻⁰⁸ 1/h												
100% Load n _{op} = 86.400:	7,4 x 10 ⁻⁰⁸ 1/h												
60% Load n _{op} = 86.400:	2,1 x 10 ⁻⁰⁸ 1/h												
*n _{op} = mean number of annual actuations, see C.4.2 and C.4.3 of DIN EN ISO 13849-1:2008													
Use the following formula to calculate the mean number of annual actuations:													
$n_{op} = (d_{op} \cdot h_{op} \cdot 3600 \text{ s/h}) \div t_{Zyklus}$													
In doing so, make the following assumptions with regard to the use of the component:													
h _{op} = mean operating time in hours per day													
d _{op} = mean operating time in days per year													
t _{Zyklus} = mean time between the start of two successive cycles of the component (e.g switching of a valve) in seconds per cycle													

- The Safety Interface Device is used in combination with one or more Multiple Light Beam Safety Devices or Safety Light Curtains to safeguard danger or hazard areas.
- The control of the machine or system that is to be safeguarded must be electrically influenceable. A switch-off command initiated by an MSI must result in an immediate shutdown of the dangerous movement.
- The "Reset" acknowledgment button for unlocking the start/restart interlock must be mounted in such a way that the entire danger zone can be seen from its mounting location.
- Message outputs (state outputs) must not be used for switching safety-relevant signals.
- The Safety Interface Device is designed for installation in a cabinet or a protective housing with a protection rating of at least IP 54.
- The 24 V DC $\pm 20\%$ power supply must guarantee safe isolation from the mains voltage and be able to bridge a power outage period of 20 ms.
- Depending on external wiring, dangerous voltages may be present at the switching outputs. In addition to the power supply, these must be switched off and safeguarded against being switched back on prior to all work on the MSI-i.
- These operating instructions must be included with the documentation of the machine on which the protective device is installed so that they are available to the operator at all times.
- In the event of changes to the MSI-i, all warranty claims against the manufacturer of the Safety Interface Device are rendered void.
- The safety distance between the AOPD and the point of operation is to be maintained. It is calculated according to the formulas for machine-specific C standards or given in the general B1 standard ISO 13855. Both the reaction time of the Test Monitoring Unit and the braking time of the machine must be taken into account.
- Two switching contacts must always be looped into the switch-off circuit of the machine. To prevent welding, relay switching contacts must be fused/protected externally according to the technical data.
- The Safety Interface Device must be exchanged after a maximum of 20 years. Repairs or the exchange of parts subject to wear and tear do not extend the service life.
- The Safety Interface Device satisfies the requirements of safety category 4 acc. to ISO 13849-1. If, however, an AOPD of a lower safety category is connected, the total category for the given path of the control cannot be higher than that of the connected AOPD.
- Cross connections between S1 and S2 are only detected by the MSI safety device if both time-staggered test signal outputs, T1 and T2, are used for the connected protective device(s) with relay output. AOPDs of type 4 with safety-relevant transistor outputs and their own cross circuit monitoring can be directly connected to S1 and S2.

2.1.2 Foreseeable misuse

Any use other than that defined under the "intended use" or which goes beyond that use is considered improper use!

e.g.
applications in explosive or easily flammable atmospheres

2.2 Competent personnel

Prerequisites for competent personnel:

- has a suitable technical education
- he knows the rules and regulations for occupational safety, safety at work and safety technology and can assess the safety of the machine

2.3 Responsibility for safety

Manufacturer and operating company must ensure that the machine and implemented Safety Interface Device function properly and that all affected persons are adequately informed and trained.

The type and content of all imparted information must not lead to unsafe actions by users.



Attention!

Such instances can jeopardize the health and lives of the personnel operating the machinery and/or may cause damage to property.

- he knows the instructions for the Safety Interface Device and the machine
- has been instructed by the responsible person on the mounting and operation of the machine and of the Safety Interface Device

The manufacturer of the machine is responsible for:

- safe machine construction
- safe implementation of the Safety Interface Device
- imparting all relevant information to the operating company
- adhering to all regulations and directives for the safe starting-up of the machine

The operator of the machine is responsible for:

- instructing the operating personnel
- maintaining the safe operation of the machine

2.4 Exemption of liability

Leuze electronic GmbH + Co. KG is not liable in the following cases:

- Safety Interface Device is not used as intended
- safety notices are not adhered to
- reasonably foreseeable misuse is not taken into account
- adhering to all regulations and directives for occupational safety and safety at work
- regular testing by competent personnel (see chapter 2.2 and 2)
- mounting and electrical connection are not properly performed
- proper function is not tested
- changes (e.g., constructional) are made to the Safety Interface Device

2.5 EMERGENCY STOP button to be connected

- It must be secured that the EMERGENCY STOP function is always and immediate effective. EMERGENCY STOP buttons must not be connected at sensor inputs which provide for muting or cycling control functions. Since MSI-i does not provide for additional sensor

inputs without special functions, no EMERGENCY STOP buttons must be connected. If an EMERGENCY STOP button is needed, the use of the extended version MSI-ix is recommended.

2.6 Additional Safety Precautions for the Special Function "Cyclical Control"

- Special safety precautions must be followed for controlling protective devices. For example, it must be impossible to step behind the protective device on the side facing the danger point. Stepping into or through the protected field would automatically cause the dangerous movement to be enabled!

- More specific regulations can be found in the European Standard EN ISO 12100-2, Control guards. In addition, the European Standard for Hydraulic Presses EN 693 contains restrictions on the minimum height of the press table and on the maximum dimensions of the access (window) opening. If these stipulations cannot be complied with, additional measures must be taken to reliably monitor the interior of the machine.

3 System Configuration and Functions

3.1 System Configuration

Two microprocessors handle the redundant processing of the signal sequences within the intelligent Modular Safety Interface MSI. The results of the two processors are continuously compared. If any deviations are found, the safety-related outputs are immediately switched off and the LED indicating an MSI failure lights up.

Sensor signals at inputs S1 and S2 are checked. Depending on which of the functions (as described below) are selected, when the protected fields of all connected AOPDs are free the MSI outputs switch automatically to the ON state (without start/restart interlock) or remain in

3.2 DIP Switch Settings

3.2.1 DIP Switch Settings for the MSI-i Module

Cut off the voltage supply to the interface (see safety precautions) loosen the subassembly with the imprint

the OFF state until the reset button has been pressed and released (with start/restart interlock = standard operating mode).

On the output side, the MSI-s is equipped with two positive-guided, normally open contacts.

The MSI safety interface comes in a 35 mm-wide slide-in housing that holds the MSI-i module and the /R output module. It is suitable for mounting on a grounded 35 mm standard rail.

"MSI-i" and pull this module partly out of the housing before resetting the DIP switches:



Functions **only** in conjunction with external wiring, see Chapter 3.3:

DIP Switch	DS4	DS3	DS2	DS1
Function	None	Locking	External Device Monitoring	Cycle Time-limit
Up		restart interlock only	Static•- none••	30 min.
Down		start/restart interlock* - none**	dynamic	30 sec.

Factory setting: all switches down

* See Chapter 3.3.1.1 – 3.3.1.3

** See Chapter 3.3.1.4

• See Chapter 3.3.1.2

•• See Chapter 3.3.1.3– 3.3.1.5

3.3 Operating Modes and Functions

- MSI-i/R permits the following modes of operation and functions:
- Guard function offers the possibility of combining start/restart interlock and external device monitoring (see below).
- Five operating modes can be selected by means of external wiring and the DIP switches DS2 and DS3 on the MSI-i module.
- Cyclical operation as single break or double break operation with guard function. In cyclical operation,

the AOPD connected at S1 controls the process. Special safety precautions are required as described in Chapter 2.3, Safety Precautions. Start/restart interlock is a necessary precondition for cyclical operation. Whenever cyclical operation is selected, terminal 13 must be connected to 24 V DC by way of a reset button! See more in Chapter 3.3.3. A three-point keyed switch is used to select among the operating modes. Changes at this keyed switch may only be made by trained specialists. If just one of the available operating modes is going to be required, we recommend permanently wiring this mode using a bridge.

3.3.1 Operating Modes Interlocking Functions and External Device Monitoring

The following 5 combinations can be selected by externally wiring the MSI Safety interface and/or by changing

the settings of the DIP switches DS2 and DS3 in the MSI Module:

OPERATING MODES			
Chapter	Type of Locking	Type of External Device Monitoring	Cyclical Function
3.3.1.1	With start/restart interlock	with dynamic ext. device monitoring	possible
3.3.1.2	With start/restart interlock	with static ext. device monitoring	possible
3.3.1.3	With start/restart interlock	without external device monitoring	possible
3.3.1.4	Without start/restart interlock	without external device monitoring	not possible
3.3.1.5	With start/without restart interlock	without external device monitoring	not possible



MSI safety interface is factory-set for the operating mode "with start/restart interlock and dynamic external device monitoring". If this setting is changed, these functions (i.e. the appropriate safety level) must be guaranteed by other means.

- Types of interlocking functions

The „start interlock function“ ensures that when the system is switched on or when the supply voltage returns, even if the protected field is free the safety-related output contacts (OSSDs) do not automatically go into ON state, but rather wait until the reset button has been pressed and let go. The „start/restart interlock function“ prevents the OSSDs from automatically entering the ON state when the protected fields of one or more of the connected AOPDs are released again after an interruption. Here as well, the reset button must be pressed and let go to initiate the system.

Cyclical operation and muting are not possible if there is no locking (and hence no reset button) since the start button is also used to perform the function of the cyclical and muting reset.

- Types of External Device Monitoring

The function „dynamic external device monitoring“ monitors the relays connected downstream from the MSI safety interface. Each time before the OSSDs switch to the ON state, a check is made of whether the subsequent circuit elements have closed and reopened. If they have not, the OSSDs of the MSI safety interface remain in the OFF state. If the function „static external device monitoring“ is selected, a check is merely made of whether the subsequent circuit elements are in an open state. If they are, the start/restart interlock can be initiated.

3.3.1.1 Operating Mode: With Start/Restart Interlock – With Dynamic External Device Monitoring

External wiring requirements:

- Terminal 13 connected to 24 V DC by way of a start button
- Terminal 14 connected to 0 V by way of feedback contacts of the positive-guided downstream relay

Required DIP switch settings in the MSI module (Chapter 3.2):

- DS3 down DS2 down (factory setting at delivery)

Start/restart interlock is no longer active when the protected fields of all connected AOPDs are free, the downstream relays have returned to their original state, and the reset button is pressed and released.

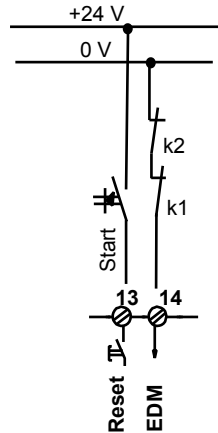

3.3.1.2 Operating Mode: With Start/Restart Interlock – With Static External Device Monitoring

External wiring requirements:

- Terminal 13 connected to 24 V DC by way of a start button
- Terminal 14 connected to 0 V by way of feedback contacts of the positive-guided downstream relay

Required DIP switch settings in the MSI module (Chapter 3.2):

- DS3 down DS2 up

In this operating mode, if the protected fields are free, a check is merely made of whether the downstream circuit elements have returned to their original state. If so, a release is issued by pressing and letting go of the reset button.

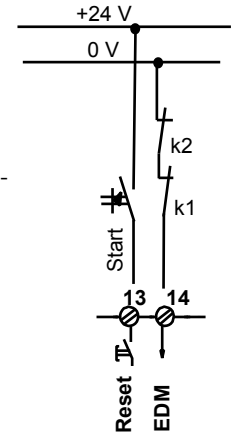

The dynamic monitoring of the downstream relays, which may be required in order to maintain the safety category, must be performed by other means.

3.3.1.3 Operating Mode: With Start/Restart Interlock – Without External Device Monitoring

External wiring requirements:

Terminal 13 connected to 24 V DC "Reset" by way of a start button

Terminal 14 connected to 0 V "EDM"

Required DIP switch settings in the MSI module (Chapter 3.2):

DS3 down DS2 up

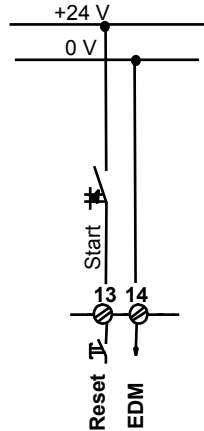

The dynamic monitoring of the downstream relays, which may be required in order to maintain the safety category, must be performed by other means.

3.3.1.4 Operating Mode: Without Start/Restart Interlock – Without External Device Monitoring

Cyclical operation not possible in this operating mode!

External wiring requirements:

Terminal 13 connected to 0 V "Reset"

Terminal 14 connected to 24 V DC "EDM"

Required DIP switch settings in the MSI module (Chapter 3.2):

DS3 down DS2 up

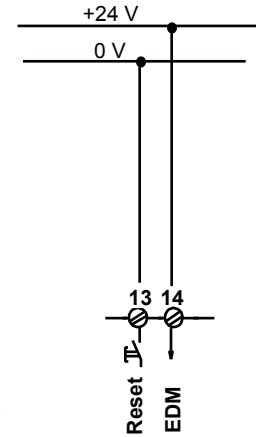

After the supply voltage is applied, the OSSDs immediately go into the ON state if all of the protected fields of the connected AOPDs are free. In this case, the start/restart interlock function and the dynamic monitoring of the downstream relays, which may be required in order to maintain the safety category, must be performed by other means.

3.3.1.5 Operating Mode: With Start/Without Restart Interlock – Without External Device Monitoring

Cyclical operation is not possible in this operating mode!

External wiring requirements:

Terminal 13 connected to 0 V
"Reset"

Terminal 14 connected to
"EDM" 24 V DC

Required DIP switch settings in
the MSI module (Chapter 3.2):

DS3 up DS2 up

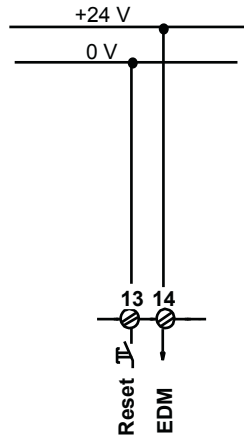

After the supply voltage is applied, the OSSDs remain in the OFF state even if all of the protected fields of the connected AOPDs are free.

When the protected fields of all connected AOPDs are initially free, the OSSDs first enter the ON state when the protected field of the AOPD connected at S1 (for Type 4: S1 and S2) is interrupted and released. Only then do the rest of the connected AOPDs respond to the interruption and release of their own protected fields by switching the OSSDs directly to the OFF and ON states.

In this case, the start/restart interlock function and the dynamic monitoring of the downstream circuit elements, which may be required in order to maintain the safety category, must be performed by other means.

3.3.2 Guard Operation, Test Function

If the protected fields are free, it is possible to simulate an interruption of the protected field of the AOPD connected at S1 (for Type 4: S1 and S2) by way of the "Clear" input. During this procedure, the safety-related outputs will switch to the OFF state. Test is activated if 24 V DC at Pin 20 is disconnected via a normal closed contact.

If operating mode "Start Interlock only" (as in Chapter 3.3.1.5) is selected, the "Clear" input also serves as the remote start for the AOPD connected at S1 (for Type 4: at S1 and S2). In this case, it is no longer necessary to initiate the first start by interrupting the protected field.

3.3.3 Cyclical Operation as Single Break or Double Break with Guard Function

Special safety precautions must be taken when the protective device is used to control the machine. These

are described in Safety Precautions, Chapter 2.6.

At terminal 21 "Select" you can choose the operating modes "guard only", "single break operation" or "double break operation". Start/restart interlock is a necessary precondition for cyclical operation, which means that terminal 13 must always be connected to 24 V DC by way of the start button. There are some options available with regard to external device monitoring. It can be performed either dynamically or statically, or it can be dispensed with completely if the requirements for maintaining the safety category are fulfilled by other means.

Cyclical Operation:

The start interlock ensures that the OSSDs remain in the OFF state after the supply voltage has been switched on. The display "start/restart interlock" (symbol: lock) is constantly lit.

The following applies for single break operation:

When the start button is pressed, the readiness for cyclical operation is achieved, and the display "start/restart interlock" emits a single blink which is repeated in short intervals. The controls remain in this condition and wait for a controlling interruption of the protected field for at least 300 ms.

The following applies for double break operation:

When the start button is pressed, the readiness for cyclical operation is achieved, and the display "start/restart interlock" emits a double blink which is repeated in short intervals. After the first interruption for at least 300 ms, the display emits a repeated single blink. The controls remain in this condition and wait for the second controlling interruption of the protected field.

Cycling Operation Time monitoring

A time monitoring function prevents other controlling interruptions of the protected field after a period of 30 s following the "readiness" or the last controlling interruption of the protected field. After this 30-second period the start/restart interlocking function is automatically actuated, and the yellow LED lights constantly. By a press of the reset button, the "readiness" for further controlling interruptions may be restored.

This function safeguards against the unintentional and unexpected initiation of a processing cycle after a longer standstill. In justified cases only, and if this does not create any additional danger to the operating personnel, the time monitoring function can be switched to 30 min. by the way of the DIP switch DS1. See Chapter 3.2.1.

3.3.4 Cycling operation, Diagram

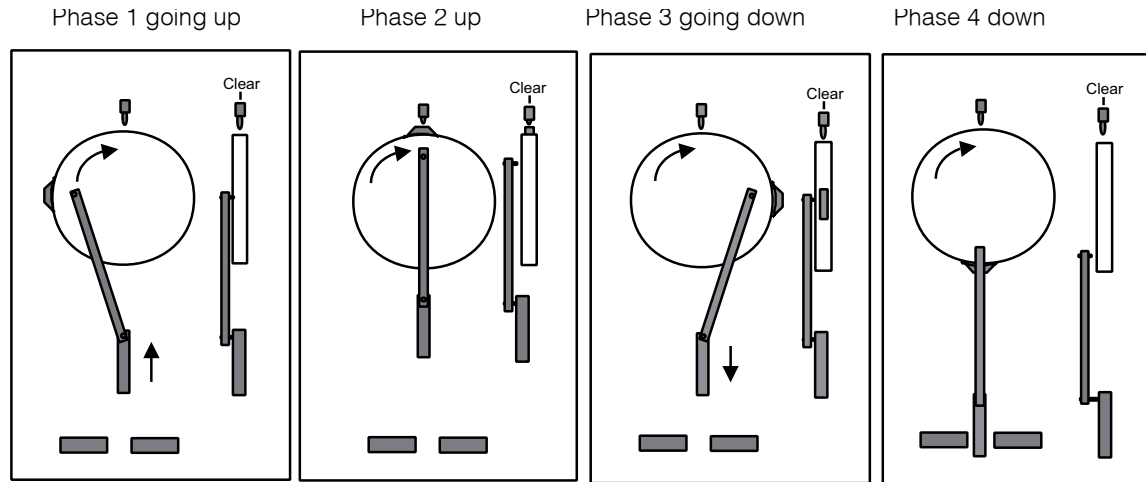

Stop

initiation after 1 or 2 protection field interruptions

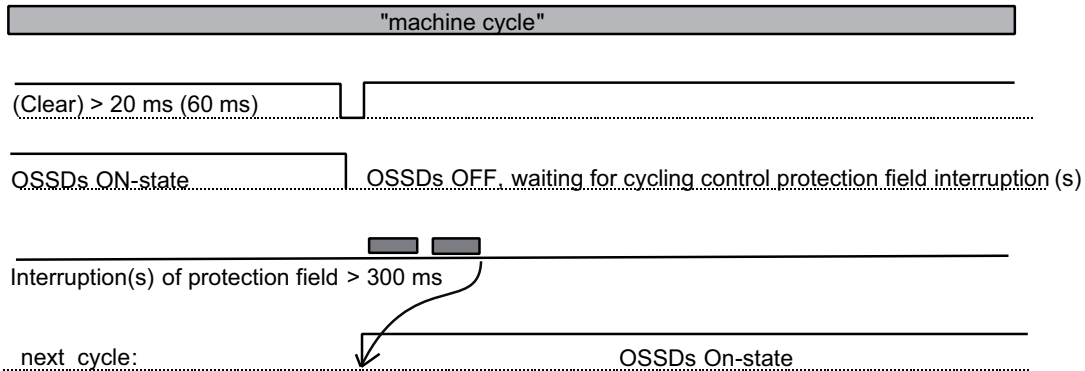

Phase 1 going up

Phase 2 up

Phase 3 going down

Phase 4 down

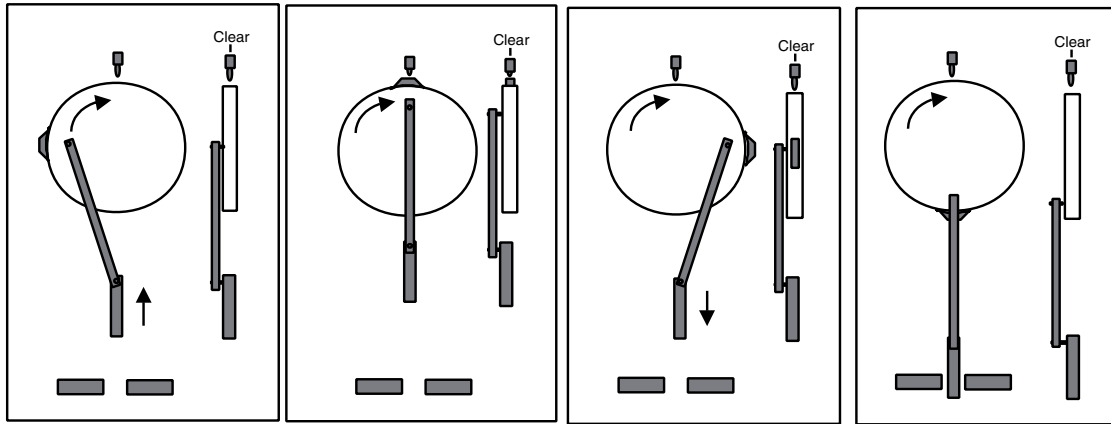

Stop

initiation after 1 or 2 protection field interruptions

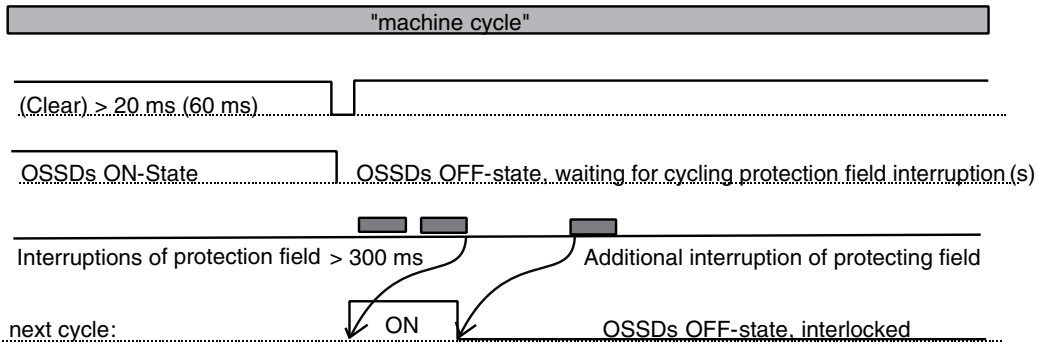

Response- and stopping performance times have to be taken in account

3.4 Displays

A number of LEDs of various colors indicate the operating status of the MSI modular safety interface. It is also possible to show the LED displays on the PC monitor

using the integrated RS 232 interface and diagnosis connector.

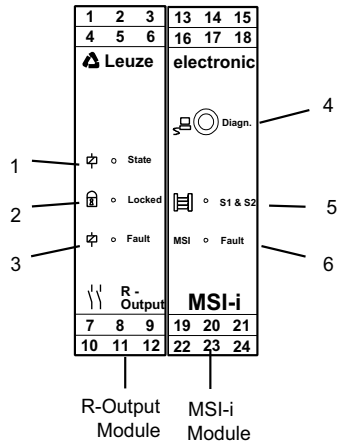

Output /R					
Position	Display/Function	Symbol	Status	LED	Color
1	Safety-related switch output	relay	on off	on on	green red
2	Start/restart interlock – Wait for 2 cycles – Wait for 1 cycle	lock	locked locked locked not locked	on impulse 2x impulse 1x off	yellow yellow yellow
3	Fault in output module	relay	fault no fault	on off	red

MSI-i Module					
Position	Display/Function	Symbol	Status	LED	Color
4	Diagnosis, RS 232 See status outputs	jack diagn.	none	none	none
5	Protected field	AOPDs S1 & S2	protected field free not free	on off	green
6	MSI fault	MSI Fault	fault no fault	on off	red

3.5 Status Outputs



Status outputs are not allowed to be used as safety-related signals in release circuits

(see also Chapter Safety. Operating Conditions and Proper Use)

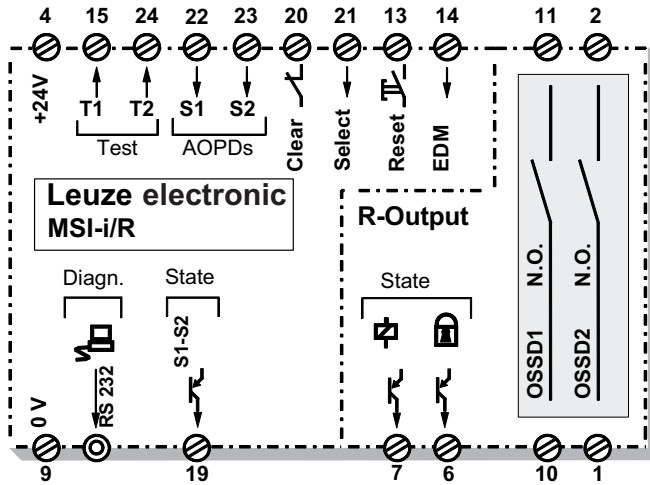

Output /R				
Terminal	Message Function	Symbol	Status	Status Output
6	Start/restart interlock – Wait for 2 cycles – Wait for 1 cycle	lock	locked locked locked not locked	active high impulse 2 x impulse 1 x active low
7	Safety-related switch status	relay	ON OFF	active high active low

MSI-i Module				
Terminal	Message Function	Symbol	Status	Status Output
Front jack	Diagnosis, RS 232 2.5 mm round connector	–	–	connected to PC with diagnosis program
19	Protected field(s)	S1 - S2	free not (all) free	active high active low

3.6 Diagnosis Function

Requirements for running the diagnosis system: a standard PC or laptop operating under Windows (Version 3.1 or higher) and the MSI software, Version 01, as well as a serial connection cable and a 2.5 mm jack plug.

- Simultaneous display of all input and output statuses as well as all LED displays on the MSI

With its diagnosis interface, the intelligent modular safety interface MSI offers a convenient way to visualize all of

the input and output statuses simultaneously on the monitor.

The connection circuit diagram as well as display fields in different colors can be shown on the screen via the connection terminals. A graphic representation of the MSI front design with the display elements as described in Chapter 3.4 also appears on the screen.

Example:

This enables the sequences at individual screw-type terminals to be tracked without the use of additional measuring instruments. The diagnosis function is equip-

ped with online help and can be operated in either English or German.

4 Electrical Connection

4.1 Installation Regulations



The general safety precautions in Chapter • must be observed. The electrical installation may be performed only if there is no voltage applied, and it must be performed by trained specialists.



In the /R versions, it is possible that high voltages may be present at the output contacts. A no-voltage state is achieved only when the 24 V DC supply voltage as well as the supply lines to the switch contacts are safely

4.2 Power Supply Requirements



The supply voltage of 24 V DC must guarantee safe mains separation and be able to bridge an interruption in voltage of 20 ms at full load. The functional earth connection of the MSI is established when snapped onto

4.3 Connecting AOPDs, Type 4 or Type 2

The examples below show possibilities for connecting and combining AOPDs of various safety categories and with various output features (relays, safety-oriented transistor outputs, cross circuit monitoring within and outside the AOPD).

AOPDs Type 4 with transistor outputs and cross connection monitoring function can directly be connected to the safety inputs S1 and S2. See Example 1.

switched off and secured against being switched on again.



Coded plug-in terminal blocks allow a connection cross-section of up to 2.5 mm². The supply voltage must be externally fused against excess current with a fuse of 2.5 AmT. The switch contacts must also be externally fused against excess current with a maximum of 4A gG. This prevents the safety-related contacts from welding together if the current load is too high!

the grounded metal mounting rail via the rear clamp fixture.

The lead for the supply voltage must be externally fused against excess current with a maximum of 2.5 AmT.

AOPDs Type 4 with relay outputs must be connected so that the odd-numbered test signal T1 are directed via the non-delaying contacts to an odd-numbered safety input (T1=>S1) and vice versa (T2=>S2). See Example 2.

AOPDs Type 2 are periodically tested using the time-displaced test signals T1 or T2. The odd-numbered test signal must be directed to an even-numbered safety input by the way of the time-delaying AOPD (T1=>S2)

and vice versa ($T2 \Rightarrow S1$). The AOPD response time to a test request must be in a range of 2 to 18 ms. See Example 3.

All available safety inputs must be occupied! In case no components are connected, the remaining inputs must be connected to the corresponding test signal using bridges. In doing so, please note that the odd-numbered test signal must be connected to the odd-

numbered safety input via the non-delaying bridge ($T1 \Rightarrow S1$) and vice versa ($T2 \Rightarrow S2$). See Example 4.

If type 2 AOPDs are connected:

- according to DIN EN IEC 61496-1, only a maximum of PL c or SIL CL 1 can be achieved!
- when cables are laid without protection, a failure detection time of up to 10 s is possible.

Example 1

1 AOPD Type 4 with 2 safety-related transistor output-sand internal cross connection monitoring function.

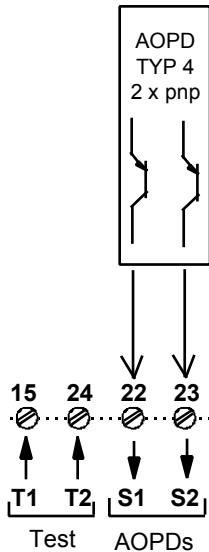

Example 2

1 AOPD Type 4 with 2 normally open relay contacts. Cross connection monitoring by using the test signals T1 and T2.

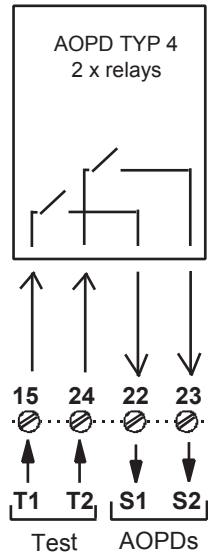

Example 3

2 AOPDs Type 2 with one safety-related transistor output each. Cross connection between the leads will be detected.

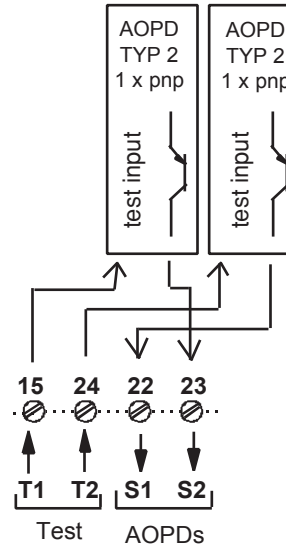

Example 4

1 AOPD Type 2 with one safety-related transistor output.

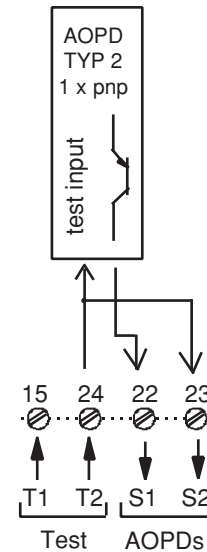

4.4 Connecting Machine Controls



The safety-related parts of the controls comprise more than the MSI-i/R described above. They also include successive control elements and even power transmission elements which must be safely and promptly shut down. Particular attention must be paid to maintaining the safety category requirements. Important information in this regard can be found in the harmonized European standard DIN EN ISO 13849-1.



Essential prerequisites for safe operation are the abilities to electrically influence the interruption of the dangerous movement and to bring the machine to a standstill as quickly as possible. These factors, as well as the response times of AOPDs and the MSI, must be taken into consideration when calculating the safety distance.

The response times depend on the type of AOPD selected (see Chapter 6, Technical Data). Other parameters, such as hand/arm/body approach speed or additional safety distance, depend on the particular application and the resolution of the AOPD being used. The European standard DIN EN ISO 13855 contains equations and examples for a variety of configurations.

Before starting the next cycle the MSI Safety Interface demands the automatic feedback of the machine cycle. The normal closed contact between +24 V and terminal 20 (Clear) must be interrupted for a minimum duration according to the Technical Data below. This causes all fed-in cycles to be cleared. The output contacts enter the OFF state when the cycle clearance procedure is performed.

5 Connection Circuit Diagram, Examples

The connection examples below show one wiring suggestion each for the MSI-i/R

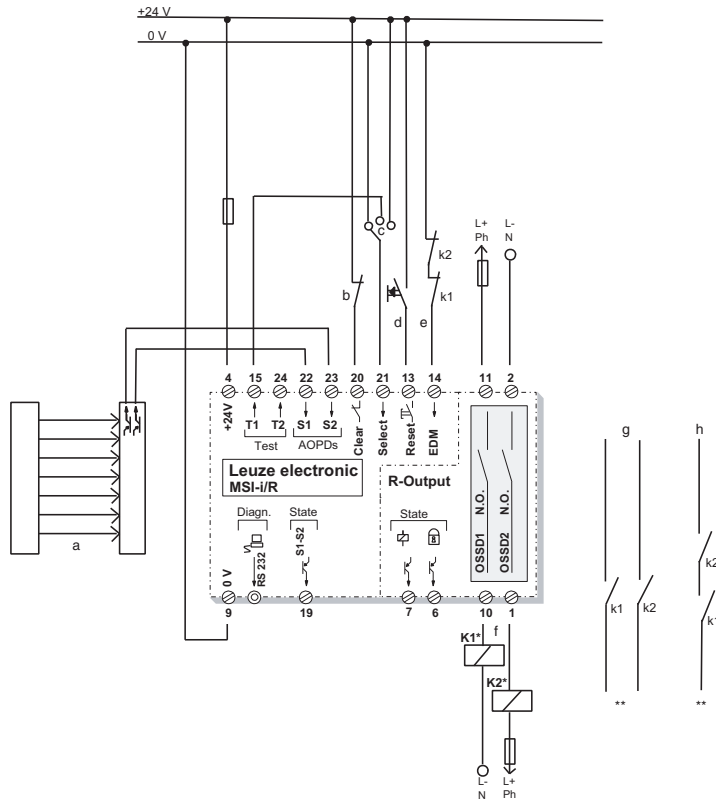

Connection example MSI-i/R with one AOPD Type 4

- a = AOPD Type 4 with guarding and control function
- b = Normally closed machine contact for cycle clearance
- c = Operating mode keyed switch (guard only = 0 V, single-break = T1, double-break = 24 V)
- d = Command device for releasing the start/restart interlock
- e = Feedback loop for external device monitoring
- Pin 19 = Indicating output "sensor status"
- Pin 7 = Indicating output "status safety outputs"
- Pin 6 = Indicating output "status restart interlock"
- f = Output Signal Switching Devices (OSSDs)
- g = Switching off path with two-channel control
- h = Switching off path with one-channel control
- * = Suitable spark suppression required
- ** = In general, both of the contacts must be used in the subsequent machine control path.
Use relays or contactors with positive-driven contacts only.

All available safety inputs must be occupied!

See Chapter . 4.3

6 Technical Data and Ordering Information

6.1 MSI-i/R

Version, Type Modular Safety Interface	MSI-i	
Type in accordance with DIN EN IEC 61496-1	Type 4	
SIL in accordance with IEC 61508	SIL 3	
Performance Level (PL) in accordance with DIN EN ISO 13849-1	PL e	
Category in accordance with DIN EN ISO 13849-1	Cat. 4	
Mean probability of a dangerous failure per hour (PFH _d)) as a function of the mean number of annual switching cycles of the relay n _{op} *	100% Load n _{op} = 4.800:	1,5 x 10 ⁻⁰⁸ 1/h
	60% Load n _{op} = 4.800:	1,2 x 10 ⁻⁰⁸ 1/h
	100% Load n _{op} = 28.800:	3,1 x 10 ⁻⁰⁸ 1/h
	60% Load n _{op} = 28.800:	1,5 x 10 ⁻⁰⁸ 1/h
	100% Load n _{op} = 86.400:	7,4 x 10 ⁻⁰⁸ 1/h
	60% Load n _{op} = 86.400:	2,1 x 10 ⁻⁰⁸ 1/h
Number of cycles until 10 % of the components have a failure to danger (B10 _d)	400,000:	100% of the max. switched current of loading cases AC1..DC13
	2,500,000:	60% of the max. switched current of loading cases AC1..DC13
	20,000,000:	60% of the max. switched current of loading cases AC1..DC13
Service life (T _M)	20 years	
Connectable safety switches and command units at S1-S2	1 AOPD, Type 4, Type 3 or up to 2 AOPDs, Type 2 (all in accordance with DIN EN IEC 61496-1)	
Test outputs T1 and T2, Test interval	200 ms	
Test impulses, time-displaced	24 ms each	
Response time AOPD Type 2 to a test request	2 to 18 ms	
Available functions	Start/restart interlock External device monitoring Guard only, single break and double break operation	
Minimum sensing field interruption for cycling control	300 ms	

Control input Start/restart interlock (Reset)	Potential-free normal open contact (button or key button)
Control input External device monitoring (EDM)	Feedback of positive-guided contacts from downstream relays (see connection diagram)
Control input Operating mode (Select)	Operating mode keyed switch or bridge for permanent operating mode
Control input Cycle clearance (Clear) for AOPDs Type 4 with transistor outputs for AOPDs Type 4 with relay outputs for AOPDs Type 2	Normal closed contact to 24 V DC in the machine cycle, at least 20 ms opening time at least 60 ms opening time at least 60 ms opening time
Status outputs Status protected fields S1- S4	pnp – Semiconductor output All protected fields free active high, 24 V DC, 60 mA max. not free active low
Safety outputs (Technical Data, see below)	Relay outputs via /R-Output
Supply voltage	24 V DC, $\pm 20\%$, external power supply (PELV) with safe mains separation and equalization for 20 ms voltage interruption required
Current consumption	approx. 200 mA without external load
External fusing	2.5 A m
Housing Enclosure rating	IP 20; must be installed in electronics cabinet or housing with an enclosure rating of at least IP 54 Mounting at 35 mm DIN standard rail
Protective class	II
Ambient temperature, Operation	0 ... + 55 °C.
Ambient temperature, Storage	-25 ... + 70 °C
Relative humidity	93 % max.
Connection type (GS-ET-20: 2014)	pluggable, coded screw-type terminals Cable cross-section min., rigid, flexible: 0.14 mm ² Cable cross-section max., rigid, flexible: 2.5 mm ² Cable cross-section AWG/kcmil, min./max.: 26/14 Cable cross-section UL AWG/kcmil: 30-12

Dimensions	See dimensional drawing
*n _{op} = mean number of annual actuations, see C.4.2 and C.4.3 of DIN EN ISO 13849-1	
Use the following formula to calculate the mean number of annual actuations:	
$n_{op} = (d_{op} \cdot h_{op} \cdot 3600 \text{ s/h}) \div t_{Zyklus}$	
In doing so, make the following assumptions with regard to the use of the component:	
h _{op} = mean operating time in hours per day	
d _{op} = mean operating time in days per year	
t _{Zyklus} = mean time between the start of two successive cycles of the component (e.g switching of a valve) in seconds per cycle	

6.2 /R-Output

OSSD safety outputs switching voltage/switching current	2 safety-related normal open contacts 60 V DC, 250 V AC, 5 A max. Minimum switching current 20 mA
OSSD external fusing (EN 60269-1)	4A gG D-fuse
Contact currents (IEC EN 60947-5-1)	AC15, 3A DC13, 2A
OSSD response time MSI (without AOPD)	for AOPD Type 4, transistor outputs 22 ms for AOPD Type 4, relay outputs 64 ms for AOPD Type 2 64 ms for safety switches (electro mechanical) 64 ms
OSSD reset time	100 ms
OSSD suitable spark extinguishing over the coils of the downstream relays	Required
 Status output "Status switch outputs" not to be used for safety circuit!	pnp semiconductor output OSSDs ON-state: active high, 24 V DC, 60 mA OSSDs OFF-state: max. active low

Status output "Status start/restart interlock"	pnp semiconductor output: guard only	
	OSSD locked:	active high, 24 V DC, 60 mA max.
	OSSD not locked:	active low
	pnp semiconductor output: wait for 2 cycles	
	OSSD locked:	impulse 2x
	OSSD not locked:	active low
	pnp semiconductor output: wait for 1 cycles	
	OSSD locked:	impulse 1x
	OSSD not locked:	active low

6.3 Dimensional Drawing

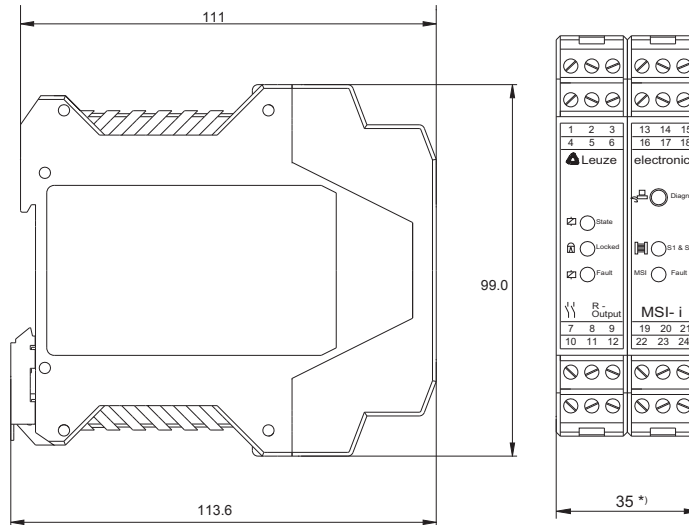

*) Stringing together without distance possible

6.4 Ordering Information

Type	Part No.
MSI-i/R	549902
MSI diagnosis software	549930
diagnosis cable 3 m	549953
diagnosis cable 5 m	549955
/R output subassembly (replacement part)	509210

7 EC Declaration of Conformity



the **sensor** people

**EG-KONFORMITÄTS-
ERKLÄRUNG
(ORIGINAL)**

**EC DECLARATION OF
CONFORMITY
(ORIGINAL)**

**DECLARATION CE DE
CONFORMITE
(ORIGINAL)**

Der Hersteller	The Manufacturer	Le constructeur
Leuze electronic GmbH + Co. KG In der Braike 1, PO Box 1111 73277 Owen, Germany		

erklärt, dass die nachfolgend aufgeführten Produkte den einschlägigen Anforderungen der genannten EG-Richtlinien und Normen entsprechen.

declares that the following listed products fulfil the relevant provisions of the mentioned EC Directives and standards.

déclare que les produits identifiés suivants sont conformes aux directives CE et normes mentionnées.

Produktbeschreibung:	Description of product:	Description de produit:
Sicherheits-Interface zur Auswertung sicherheitsrelevanter Signale und Erzeugung sicherheitsgerichteter Abschaltsignale auf Basis einer zweikanaligen Mikroprozessorseuerung	Safety interface device to evaluate safety related signals and to create safety related output switching signals based on two micro-processors	Interface de sécurité pour l'exploitation de signaux relatifs à la sécurité et la génération de signaux de coupe sécuritaires sur la base d'une commande à microprocesseur à deux canaux
Sicherheitsbauteil nach 2006/42/EG Anhang IV	safety component in acc. with 2006/42/EC annex IV	Élément de sécurité selon 2006/42/CE annexe IV
MSI (Modulares Sicherheits-Interface) (-s, -sx), (-i, -ix), (-m, -mx), (-mE, -mxE) Seriennummer siehe Typschild	MSI (Modular Safety Interface) (-s, -sx), (-i, -ix), (-m, -mx), (-mE, -mxE) Serial no. see name plates	MSI (Module interface de sécurité) (-s, -sx), (-i, -ix), (-m, -mx), (-mE, -mxE) N° série voir plaques signalétiques
Angewandte EG-Richtlinie(n):	Applied EC Directive(s):	Directive(s) CE appliquées:
2006/42/EG	2006/42/EC	2006/42/CE
2004/108/EG	2004/108/EC	2004/108/CE
Angewandte Normen:	Applied standards:	Normes appliquées:
DIN EN 62061:2013, DIN EN ISO 13849-1:2008; DIN EN ISO 13849-2:2013; GS-ET-20 :10/2014 EN 60204:2007; EN 61496-1:2013		

Benannte Stelle / Baumusterprüfbescheinigung:	Notified Body / Certificate of Type Examination:	Organisme notifié / Attestation d'examen CE de type:
-----------------------------------------------	--------------------------------------------------	------------------------------------------------------

Institut für Arbeitsschutz der Deutschen Gesetzlichen Unfallversicherung IFA
 Alte Heerstr. 111
 D-53757 St. Augustin
 Europäisch notifizierte Stelle Nr. 0121

1001187

Dokumentationsbevollmächtigter ist der genannte Hersteller, Kontakt: quality@leuze.de	Authorized for documentation is the stated manufacturer, contact: quality@leuze.de	Autorisé pour documentation est le constructeur déclaré, contact: quality@leuze.de
---------------------------------------------------------------------------------------	------------------------------------------------------------------------------------	------------------------------------------------------------------------------------

Leuze electronic GmbH + Co. KG,
 In der Braike 1 D-73277 Owen,
 quality@leuze.de

Owen, 24.04.2015
 Datum / Date / Date

Ulrich Berbach, Geschäftsführer / Director / Directeur



Ulrich Berbach, Geschäftsführer / Director / Directeur

Leuze electronic GmbH + Co. KG, Sitz Owen | Registergericht Stuttgart, HRB 230550
 Leitzingstraße 4, D-82206 Pfaffenlöhbruck | T +49 9141 5350-0 | F +49 9141 5350-1901 | info@leuze.de, www.leuze.de

Präsident Heinrich Gesselschloffen:
 Geschäftsbereich 2015/2016
 Geschäftsjahr 2015/2016
 Es gelten ausschließlich unsere aktuellen Verkaufs- und Lieferbedingungen.