

Notes on connecting and operating instructions

These connecting and operating instructions contain information on the proper use of MSI Safety Interfaces in accordance with its intended purpose.



All the information contained herein, in particular the safety notes, need to be carefully observed.

Notes regarding safety and warnings are marked by this symbol  .

These connecting and operating instructions must be stored carefully. It must be available for the entire operating time of the MSI Safety Interfaces.

The Leuze electronic GmbH + Co. KG is not liable for damages caused by improper use. Acquaintance with these instructions is an element of the knowledge required for proper use.

© Reprints and reproduction, in whole or in part, are permitted only with the explicit permission of

Leuze electronic GmbH + Co. KG
In der Braike 1
D-73277 Owen - Teck / Germany
Phone +49 (0) 7021 / 573-0
Fax +49 (0) 7021 / 573-199
info@leuze.de
www.leuze.com

Table of contents

1	System Overview and Range of Applications	4	3.3.1.5	Operating Mode With Start/Without Restart Interlock – Without External Device Monitoring	18
1.1	General Information	4	3.3.2	Muting Functions	19
1.2	Approvals	4	3.3.2.1	Sequential Muting, Muting sensors at M1 to M4	19
1.3	Terminology	5	3.3.2.2	Parallel Muting (2,5 s), Muting sensors M2 and M3	19
1.4	Nomenclature MSI-m(E)/R	6	3.3.2.3	Parallel Double Muting with extended version MSI-mx(E)/Rx only	19
2	Safety	7	3.3.2.4	Testable and Non-Testable Muting Sensors	20
2.1	Approved purpose and foreseeable improper operation	7	3.3.2.5	Muting Display Function	20
2.1.1	Proper use	8	3.3.2.6	Muting Restart while transported goods are located in the muting area	21
2.1.2	Foreseeable misuse	10	3.3.2.7	10-Minute Muting Time-Limit	21
2.2	Competent personnel	10	3.3.2.8	Example: Sequential Muting with Non-Testable Muting Sensors	22
2.3	Responsibility for safety	10	3.3.2.9	Example: Sequential Muting with Testable Muting Sensors	23
2.4	Exemption of liability	11	3.3.2.10	Example: Parallel Muting (2,5 s) with Non-Testable Muting Sensors	24
2.5	Emergency STOP buttons to be connected	12	3.3.2.11	Example: Parallel Muting (2,5 s) with Testable Muting Sensors	25
2.6	Additional Safety Precautions for the Special Function "Muting"	12	3.4	Displays	26
3.1	System Configuration	13	3.5	Status Outputs	28
3.2	DIP switch Settings	13	3.6	Diagnosis System	29
3.2.1	DIP switch Settings for the MSI-m Module	13	4	Electrical Connection	31
3.2.2	DIP switch Settings for the I/O-m Module	14	4.1	Installation Regulations	31
3.3	Operating Modes and Functions	15	4.2	Power Supply Requirements	31
3.3.1	Operating Modes Interlocking Functions and External Device Monitoring	15	4.3	Connecting AOPDs, Type 4 or Type 2	31
3.3.1.1	Operating Mode With Start/Restart Interlock – With Dynamic External Device Monitoring	16	4.4	Connecting Machine Controls	34
3.3.1.2	Operating Mode With Start/Restart Interlock – With Static External Device Monitoring	17	6.1	MSI-m(E)/R	37
3.3.1.3	Operating Mode With Start/Restart Interlock – Without External Device Monitoring	17	6.2	/R-Output	40
3.3.1.4	Operating Mode Without Start/Restart Interlock – Without External Device Monitoring	18	6.3	Dimensional Drawing	41
			6.4	Ordering Information	41
			7	EC Declaration of Conformity	42

1 System Overview and Range of Applications

1.1 General Information

The Modular Safety Interface (MSI) serves as a link between one or more active optoelectronic protective devices (AOPD), Type 2, Type 3 or Type 4, and the machine controls. All MSI safety components include start/restart interlock and external device monitoring functions that can be activated and deactivated. They are also equipped with a series of status outputs and LED displays as well as a diagnosis interface to a PC.

In addition, MSI-m(E)/R offers a selection of muting functions to suppress the protective function of an AOPD, e.g. during the time material is transported through the sensing field. Special safety regulations for

cyclical operation and muting are described in Chapter 2.6 below.

Leuze electronic offers a variety of additional MSI Safety Interfaces with standard or special functions, for example with cycling mode (controlling a machine by the AOPD's sensing field).

All MSI safety modules are equipped with relay outputs.

All information also applies to UL compliant version MSI-mE/R, provided that nothing to the contrary is stated.

1.2 Approvals

Europe
EC Type Examination DIN EN ISO 13849-1/2 GS-ET-20 "Safety relays" IFA Institut für Arbeitsschutz der Deutschen Gesetzlichen Unfallversicherung D-53757 Sankt Augustin

1.3 Terminology

AOPD	Active Optoelectronic Protective Device
Diagn.	Diagnosis Function
EDM	External Device Monitoring
ESPE	Electro-sensitive Protecting Equipment
Fault	Relay Fault
I/O-m Module	Input/Output Module
Lamp Warn.	Muting Indicator Failure Warning
Locked	Start/Restart Interlock active
M1 - M4	Muting Input 1 - 4
N.O.	Normal Open Contact
OSSD	Safety-Related Switching Output
Reset	Start/Restart Interlock Initiator
RS 232	Interface RS 232
S1, S2	Safety input 1, 2
S1 & S2	Protected Fields Free/Interrupted
Test	Test Signal Outputs
T1, T2	Test Signal Output 1, 2
Warn. (I/O-m Module)	Warning: muting indicator defective

1.4 Nomenclature MSI-m(E)//R

MSI	Modular Safety Interface
m	with muting function This version offers the following standard functions for either 1 AOPDs, Type 4, or up to 2 AOPDs, Type 2: <ul style="list-style-type: none">– Start/restart interlock– External device monitoring– Diagnosis function and the following special functions for 1 AOPD Type 4 or 1 AOPD Type 2: <ul style="list-style-type: none">– Sequential muting– Parallel muting (2.5 s)
/R	Relay output: <ul style="list-style-type: none">– two normal open safety contacts, OSSD 1 and OSSD 2
(E)	UL compliant version <ul style="list-style-type: none">– additional housing for convection

2 Safety

Before using the Safety Interface Device, a risk evaluation must be performed according to valid standards (e.g. ISO 14121, EN ISO 12100-1, ISO 13849-1, EN 62061). The result of the risk assessment determines the required safety level of the Safety Interface Device (see table in chapter 2.1.1). For mounting, operating and testing, document "MSI-m(E)/R Modular Safety Interface Device" as well as all applicable national and international standards, regulations, rules and directives must be observed. Relevant and supplied documents must be observed, printed out and handed to the affected personnel.

Before working with the Safety Interface Device, completely read and understand the documents applicable to your task.

In particular, the following national and international legal regulations apply for the start-up, technical inspections and work with safety sensors:

- Machinery directive 2006/42/EC

2.1 Approved purpose and foreseeable improper operation



Warning!

A running machine can cause severe injuries!

- Low Voltage Directive 2006/95/EC
- Electromagnetic compatibility directive 2004/108/EC
- Use of Work Equipment Directive 89/655/EEC supplemented by Directive 95/63 EC
- OSHA 1910 Subpart O
- Safety regulations
- Accident-prevention regulations and safety rules
- Ordinance on Industrial Safety and Health and Labor Protection Act
- Device Safety Act



For safety-related information you may also contact the local authorities (e.g., industrial inspectorate, employer's liability insurance association, labor inspectorate, occupational safety and health authority).

Make certain that, during all conversions, maintenance work and inspections, the system is securely shut down and protected against being restarted again.

2.1.1 Proper use

The Safety Interface Device must only be used after it has been selected in accordance with the respectively applicable instructions and relevant standards, rules and regulations regarding labor protection and occupational safety, and after it has been installed on the machine, connected, commissioned, and checked by a competent person.

- When selecting the Safety Interface Device it must be ensured that its safety-related capability meets or exceeds the required performance level PLr ascertained in the risk assessment.

The following table shows the safety-related characteristic parameters of the MSI-m(E)/R modular Safety Interface Devices.

Type in accordance with DIN EN IEC 61496-1	Type 4												
SIL in accordance with IEC 61508	SIL 3												
Performance Level (PL) in accordance with DIN EN ISO 13849-1	PL e												
Category in accordance with DIN EN ISO 13849-1	Cat. 4												
Mean probability of a dangerous failure per hour (PFH _d) as a function of the mean number of annual switching cycles of the relay n _{op} *	<table> <tr> <td>100% Last n_{op} = 4.800:</td> <td>1,5 x 10⁻⁰⁸ 1/h</td> </tr> <tr> <td>60% Last n_{op} = 4.800:</td> <td>1,2 x 10⁻⁰⁸ 1/h</td> </tr> <tr> <td>100% Last n_{op} = 28.800:</td> <td>3,1 x 10⁻⁰⁸ 1/h</td> </tr> <tr> <td>60% Last n_{op} = 28.800:</td> <td>1,5 x 10⁻⁰⁸ 1/h</td> </tr> <tr> <td>100% Last n_{op} = 86.400:</td> <td>7,4 x 10⁻⁰⁸ 1/h</td> </tr> <tr> <td>60% Last n_{op} = 86.400:</td> <td>2,1 x 10⁻⁰⁸ 1/h</td> </tr> </table>	100% Last n _{op} = 4.800:	1,5 x 10 ⁻⁰⁸ 1/h	60% Last n _{op} = 4.800:	1,2 x 10 ⁻⁰⁸ 1/h	100% Last n _{op} = 28.800:	3,1 x 10 ⁻⁰⁸ 1/h	60% Last n _{op} = 28.800:	1,5 x 10 ⁻⁰⁸ 1/h	100% Last n _{op} = 86.400:	7,4 x 10 ⁻⁰⁸ 1/h	60% Last n _{op} = 86.400:	2,1 x 10 ⁻⁰⁸ 1/h
100% Last n _{op} = 4.800:	1,5 x 10 ⁻⁰⁸ 1/h												
60% Last n _{op} = 4.800:	1,2 x 10 ⁻⁰⁸ 1/h												
100% Last n _{op} = 28.800:	3,1 x 10 ⁻⁰⁸ 1/h												
60% Last n _{op} = 28.800:	1,5 x 10 ⁻⁰⁸ 1/h												
100% Last n _{op} = 86.400:	7,4 x 10 ⁻⁰⁸ 1/h												
60% Last n _{op} = 86.400:	2,1 x 10 ⁻⁰⁸ 1/h												
*n _{op} = mean number of annual actuations, see C.4.2 and C.4.3 of DIN EN ISO 13849-1:2008													
Use the following formula to calculate the mean number of annual actuations:													
$n_{op} = (d_{op} \cdot h_{op} \cdot 3600 \text{ s/h}) \div t_{Zyklus}$													
In doing so, make the following assumptions with regard to the use of the component:													
h _{op} = mean operating time in hours per day													
d _{op} = mean operating time in days per year													
t _{Zyklus} = mean time between the start of two successive cycles of the component (e.g switching of a valve) in seconds per cycle													

- The Safety Interface Device is used in combination with one or more Multiple Light Beam Safety Devices or Safety Light Curtains to safeguard danger or hazard areas.
- The control of the machine or system that is to be safeguarded must be electrically influenceable. A switch-off command initiated by an MSI must result in an immediate shutdown of the dangerous movement.
- The "Reset" acknowledgment button for unlocking the start/restart interlock must be mounted in such a way that the entire danger zone can be seen from its mounting location.
- Message outputs (state outputs) must not be used for switching safety-relevant signals.
- The Safety Interface Device is designed for installation in a cabinet or a protective housing with a protection rating of at least IP 54.
- The 24 V DC $\pm 20\%$ power supply must guarantee safe isolation from the mains voltage and be able to bridge a power outage period of 20 ms.
- Depending on external wiring, dangerous voltages may be present at the switching outputs. In addition to the power supply, these must be switched off and safeguarded against being switched back on prior to all work on the MSI-m(E)/R.
- These operating instructions must be included with the documentation of the machine on which the protective device is installed so that they are available to the operator at all times.
- In the event of changes to the MSI-m(E)/R, all warranty claims against the manufacturer of the Safety Interface Device are rendered void.
- The safety distance between the AOPD and the point of operation is to be maintained. It is calculated according to the formulas for machine-specific C standards or given in the general B1 standard ISO 13855. Both the reaction time of the Test Monitoring Unit and the braking time of the machine must be taken into account.
- Two switching contacts must always be looped into the switch-off circuit of the machine. To prevent welding, relay switching contacts must be fused/protected externally according to the technical data.
- The Safety Interface Device must be exchanged after a maximum of 20 years. Repairs or the exchange of parts subject to wear and tear do not extend the service life.
- The Safety Interface Device satisfies the requirements of safety category 4 acc. to ISO 13849-1. If, however, an AOPD of a lower safety category is connected, the total category for the given path of the control cannot be higher than that of the connected AOPD.
- Cross connections between S1 and S2 are only detected by the MSI safety device if both time-staggered test signal outputs, T1 and T2, are used for the connected protective device(s) with relay output. AOPDs of type 4 with safety-relevant transistor outputs and their own cross circuit monitoring can be directly connected to S1 and S2.

2.1.2 Foreseeable misuse

Any use other than that defined under the "intended use" or which goes beyond that use is considered improper use!

e.g.
applications in explosive or easily flammable atmospheres

2.2 Competent personnel

Prerequisites for competent personnel:

- has a suitable technical education
- he knows the rules and regulations for occupational safety, safety at work and safety technology and can assess the safety of the machine

2.3 Responsibility for safety

Manufacturer and operating company must ensure that the machine and implemented Safety Interface Device function properly and that all affected persons are adequately informed and trained.

The type and content of all imparted information must not lead to unsafe actions by users.



Attention!

Such instances can jeopardize the health and lives of the personnel operating the machinery and/or may cause damage to property.

- he knows the instructions for the Safety Interface Device and the machine
- has been instructed by the responsible person on the mounting and operation of the machine and of the Safety Interface Device

The manufacturer of the machine is responsible for:

- safe machine construction
- safe implementation of the Safety Interface Device
- imparting all relevant information to the operating company
- adhering to all regulations and directives for the safe starting-up of the machine

The operator of the machine is responsible for:

- instructing the operating personnel
- maintaining the safe operation of the machine

2.4 Exemption of liability

Leuze electronic GmbH + Co. KG is not liable in the following cases:

- Safety Interface Device is not used as intended
- safety notices are not adhered to
- reasonably foreseeable misuse is not taken into account
- adhering to all regulations and directives for occupational safety and safety at work
- regular testing by competent personnel (see chapter 2.2 and 2)
- mounting and electrical connection are not properly performed
- proper function is not tested
- changes (e.g., constructional) are made to the Safety Interface Device

2.5 Emergency STOP buttons to be connected

- It must be secured that the EMERGENCY STOP function is always and immediate effective. EMERGENCY STOP buttons must not be connected at sensor inputs which provide for muting or cycling control functions. Since MSI-m(E)/R does not provide for additional

sensor inputs without special functions, no EMERGENCY STOP buttons must be connected. If an EMERGENCY STOP button is needed, the use of the extended version MSI-mx(E)/Rx is recommended.

2.6 Additional Safety Precautions for the Special Function "Muting"

- Muting is the intended, regulated suppression of the safety function of an AOPD. It is used, for instance, to allow the material flow to pass through the protected field without triggering a signal to shut down the machine.
- During the muting function the protective function of this AOPD is no longer active! For this reason other measures must be taken to ensure that it is not possible to reach or go into the danger zone. For instance, perhaps the material transport completely fills the access area, or perhaps there is no danger while muting is active, such as during the return motion of a tool.
- The muting sensors must be placed so that it is impossible to manipulate them using simple means. For example, optical sensors can be mounted so high or so far apart that the operating personnel cannot cover them either simultaneously or at all. If switches are used, we recommend a concealed installation.
- The operating personnel must be expressly informed that the protective device offers no protection in the muting state. Any manipulations of or unauthorized entries into the system present immediate danger to personnel.
- An additional sign should be put up stating that the safety light grid offers no protection when the Muting indicator is lit and it is dangerous to reach or walk through the protected field. Muting indicators, controlled by the MSI, and this sign should be placed in a

3 System Configuration and Functions

3.1 System Configuration

Two microprocessors handle the redundant processing of the signal sequences within the intelligent Modular Safety Interface MSI. The results of the two processors are continuously compared. If any deviations are found, the safety-related outputs are immediately switched off and the LED indicating an MSI failure lights up.

Sensor signals at inputs S1 and S2 are checked. Depending on which of the functions (as described below) are selected, when the protected fields of all connected AOPDs are free the MSI outputs switch automatically to the ON state (without start/restart interlock) or remain in

3.2 DIP switch Settings

3.2.1 DIP switch Settings for the MSI-m Module

Cut off the voltage supply to the interface (see safety precautions) loosen the subassembly with the imprint

the OFF state until the reset button has been pressed and released (with start/restart interlock = standard operating mode).

On the output side, the MSI-m(E)/R is equipped with two positive-guided, normally open contacts.

The MSI safety interface comes in a 52,5 mm/70 mm-wide slide-in housing that holds the MSI-m module, the I/O-m module and the /R output module. It is suitable for mounting on a grounded 35 mm standard rail.

MSI-m and pull this module partly out of the housing before resetting the DIP switches:



Functions **only** in conjunction with external wiring, see Chapter 3.3:

DIP Switch	DS4	DS3	DS2	DS1
Function	None	Locking	External Device Monitoring	None
Up		start interlock only	static• - none••	
Down		start/restart interlock* - none**	dynamic	

Factory setting: all switches down

* See Chapter 3.3.1.1 – 3.3.1.3

** See Chapter 3.3.1.4

• See Chapter 3.3.1.2

•• See Chapter 3.3.1.3 – 3.3.1.5

3.2.2 DIP switch Settings for the I/O-m Module

Cut off the voltage supply to the interface (see safety precautions) loosen the subassembly I/O-m to the right

of the MSI-m module and pull it partly out of the housing before resetting the DIP switches:



DIP Switch	MU4	MU3	MU2	MU1
Function	Muting Range 1	Muting Sensors	Muting Time-limit	Muting function
Up	only S1	non-testable	none	none
Down	S1 & S2	testable	10 min.	Muting Range 1

Factory setting: all switches down

3.3 Operating Modes and Functions

- MSI-m/R permits the following modes of operation and functions:
- Guard function offers the possibility of combining start/restart interlock and external device monitoring (see below).
- Five operating modes can be selected by means of external wiring and the DIP switches DS2 and DS3 on the MSI-m module.
- Muting function by way of testable or non-testable muting sensors in sequential or parallel muting mode. Further details are given in Chapter 3.2.2.

3.3.1 Operating Modes Interlocking Functions and External Device Monitoring

The following 5 combinations can be selected by externally wiring the MSI Safety interface and/or by changing

the settings of the DIP switches DS2 and DS3 in the MSI Module:

OPERATING MODES			
Chapter	Type of Locking	Type of External Device Monitoring	Muting Function
3.3.1.1	With start/restart interlock	with dynamic ext. device monitoring	possible
3.3.1.2	With start/restart interlock	with static ext. device monitoring	possible
3.3.1.3	With start/restart interlock	without external device monitoring	possible
3.3.1.4	Without start/restart interlock	without external device monitoring	not possible
3.3.1.5	With start/without restart interlock	without external device monitoring	not possible



The MSI safety interface is factory-set for the operating mode "with start/restart interlock and dynamic external device monitoring". If this setting is changed, these functions (i.e. the appropriate safety level) must be guaranteed by other means.

- Types of interlocking functions
The start interlock function ensures that when the system is switched on or when the supply voltage returns, even if the protected field is free the safety-related output contacts (OSSDs) do not automatically

go into ON state, but rather wait until the reset button has been pressed and let go.

The start/restart interlock function prevents the OSSDs from automatically entering the ON state when the protected fields of one or more of the connected AOPDs are released again after an interruption. Here as well, the reset button must be pressed and let go to initiate the system. Muting is not possible if there is no locking (and hence no reset button) since the start button is also used to perform the function muting reset.

- Types of External Device Monitoring

The function dynamic external device monitoring monitors the relays connected downstream from the MSI safety interface. Each time before the OSSDs switch to the ON state, a check is made of whether the subsequent circuit elements have closed and reopened. If they have not, the OSSDs of the MSI safety interface remain in the OFF state.

If the function static external device monitoring is selected, a check is merely made of whether the subsequent circuit elements are in an open state. If they are, the start/restart interlock can be initiated.

3.3.1.1 Operating Mode With Start/Restart Interlock – With Dynamic External Device Monitoring

External wiring requirements:

Terminal 13 connected to 24 V DC by way of a "Reset" start button

Terminal 14 connected to 0 V by way of feedback contacts of the positive-guided downstream relay

Required DIP switch settings in the MSI module (Chapter 3.2):

DS3 down DS2 down (factory setting at delivery)

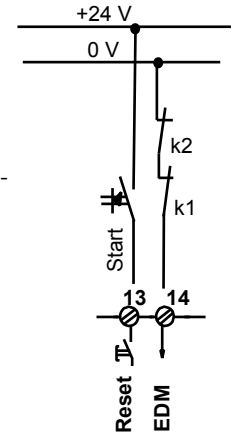

Start/restart interlock is no longer active when the protected fields of all connected AOPDs are free, the downstream relays have returned to their original state, and the reset button is pressed and released.

3.3.1.2 Operating Mode With Start/Restart Interlock – With Static External Device Monitoring

External wiring requirements:

Terminal 13 connected to 24 V DC by way of a start button
"Reset"

Terminal 14 connected to 0 V by way of feedback contacts of the positive-guided downstream relay

Required DIP switch settings in the MSI module (Chapter 3.2):

DS3 down DS2 up

In this operating mode, if the protected fields are free, a check is merely made of whether the downstream circuit elements have returned to their original state. If so, a release is issued by pressing and letting go of the reset button.

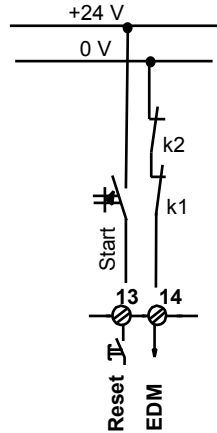

3.3.1.3 Operating Mode With Start/Restart Interlock – Without External Device Monitoring

External wiring requirements:

Terminal 13 connected to 24 V DC "Reset" by way of a start button

Terminal 14 connected to 0 V "EDM"

Required DIP switch settings in the MSI module (Chapter 3.2):

DS3 down DS2 up



The dynamic monitoring of the downstream relays, which may be required in order to maintain the safety category, must be performed by other means.

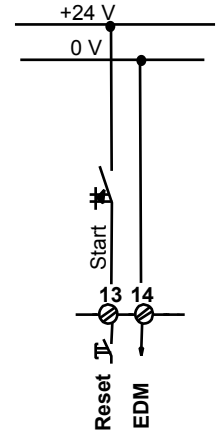

The dynamic monitoring of the downstream relays, which may be required in order to maintain the safety category, must be performed by other means.

3.3.1.4 Operating Mode Without Start/Restart Interlock – Without External Device Monitoring

Muting operation is not possible in this operating mode!

External wiring requirements:

Terminal 13 connected to 0 V
"Reset"

Terminal 14 connected to
"EDM" 24 V DC

Required DIP switch settings in the MSI module (Chapter 3.2):

DS3 down DS2 up

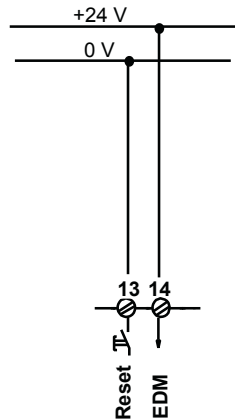

After the supply voltage is applied, the OSSDs immediately go into the ON state if all of the protected fields of the connected AOPDs are free. In this case, the start/restart interlock function and the dynamic monitoring of the downstream relays, which may be required in order to maintain the safety category, must be performed by other means.

3.3.1.5 Operating Mode With Start/Without Restart Interlock – Without External Device Monitoring

Muting operation is not possible in this operating mode!

External wiring requirements:

Terminal 13 connected to 0 V
"Reset"

Terminal 14 connected to
"EDM" 24 V DC

Required DIP switch settings in the MSI module (Chapter 3.2):

DS3 up DS2 up

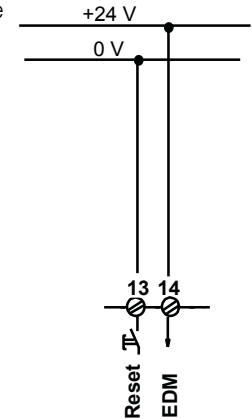

After the supply voltage is applied, the OSSDs remain in the OFF state even if all of the protected fields of the connected AOPDs are free.

When the protected fields of all connected AOPDs are initially free, the OSSDs first enter the ON state when the protected field of the AOPD connected at S1 (for Type 4: S1 and S2) is interrupted and released. Only then do the rest of the connected AOPDs respond to the interruption and release of their own protected fields by switching the OSSDs directly to the OFF and ON states.

In this case, the start/restart interlock function and the dynamic monitoring of the downstream circuit elements, which may be required in order to maintain the safety category, must be performed by other means.

3.3.2 Muting Functions

Muting is the intended, regulated suppression of the protective function. Special safety precautions must be observed if muting is being used (see Chapter 2.6).

Muting operation is initiated by the muting sensors connected to the MSI-m. The MSI-m can ascertain the muting mode based on which of the muting inputs (M1 to M4) are occupied. For instance, sequential muting will be performed when all inputs are occupied, and parallel muting takes place when M2 and M3 are occupied. Further more, both of the Muting indicators must be connected. See Chapter 3.3.2.5 for more details.

Special note for muting Type 2 AOPDs

When the DIP switch MU4 in the I/O-m module is factory-set (down), the muting function applies for safety inputs S1 and S2. If a Type 2 AOPD is going to be muted, the muting range 1 must be reset to "S1 only" at MU4 (up). In addition, the Type 2 AOPD to be muted must be connected at S1. For the setting, see Chapter 3.2.2.

3.3.2.1 Sequential Muting, Muting sensors at M1 to M4

Sequential muting requires the connection of 4 muting sensors and their damping in a predetermined sequence. It is preferred when the material being transported (i.e. the transport vehicle) always has consistent dimensions and there is sufficient space available for the material intake. Example: car bodies in the automobile industry. Examples are shown in Chapter 3.3.2.8 and 3.3.2.9.

3.3.2.2 Parallel Muting (2,5 s), Muting sensors M2 and M3

The muting process is initiated if the two inputs switch simultaneously (within 2.5 s of each other). Parallel muting is used when material of inconsistent size is being conveyed or when there is limited room in front of the muting station.

Parallel muting can be performed by two switches or two light barriers (through-beam operation or retro-reflective light barriers whose beam paths intersect behind the protected field but within the danger zone). Examples of these and other possibilities can be found in Chapter 3.3.2.10 and 3.3.2.11.

3.3.2.3 Parallel Double Muting with extended version MSI-mx(E)/Rx only

Parallel double muting is not possible with MSI-m! If muting is needed for two independent ranges, e.g. the entrance and exit area of a packaging line, the extended safety interface MSI-mx(E)/Rx takes on this task. Ask Leuze electronic or its representatives for further information.

3.3.2.4 Testable and Non-Testable Muting Sensors

The following devices are suitable for use as muting sensors:

- non-testable light barriers (through-beam operation or retro-reflective barriers with pnp output, dark-switching)
- testable and non-testable reflective light scanners (pnp output, light-switching)
- mechanical limit switches
- inductive proximity switches
- induction loops if metallic objects are being conveyed into the path to be muted



The cables to the individual muting sensors must be laid separately.

Non-Testable Muting Sensors

Requirement: DIP switch MU3 in the I/O-m module must be up

- pnp or switch output must provide 0 V in the non-damped state
- pnp or switch output must provide 24 V DC in the damped state

Testable Muting Sensors

Requirement: DIP switch MU3 in the I/O-m module must be down (factory setting)

- Reflective light scanners, light-switching, are suitable. Activating/test input required, Response time: 2 to 18 ms
- MSI-m test signal T1 must be used for the muting sensor at M2
- MSI-m test signal T2 must be used for the muting sensor at M3
- pnp output must provide 0 V in the non-damped state and 24 V DC (plus abovementioned test impulses) in the damped state

Example: SLS SR8.8/ER8/66-S12, polarized for light-switching, from Leuze electronic

3.3.2.5 Muting Display Function

Single muting for S1/S2, or in the case of type 2 for S1 only

In case of muting, terminal 28 will deliver 24 V DC to the muting indicator 1 connected to it to indicate the muting.

Terminal 29 serves as backup for the case that muting indicator 1, which is connected to terminal 28, should fail (broken filament or interrupted supply). To ensure trouble-free operation, also in the case of malfunction of Muting indicator 1 connected to terminal 28, a Muting indicator 2 must be connected to terminal 29 to serve as

back-up unit to take over the indicating function in case of failure.

With the automatic switching over from Muting indicator 1 to Muting indicator 2, the assigned LED "lamp warn " on the I/O mx module will flash up (1 pulse). If muting lamp 2 should fail (it is monitored constantly, even if it is not switched on), the LED "lamp warn " will also flash up (2 pulse).

In addition to the indication, these pulses (1 pulse or 2 pulses) are also directed to output terminal 30. This output will deliver an active-high signal during trouble-free operation. However, if the second indicator also fails, the MSI-m will enter a state of malfunction and the OSSDs will switch to the OFF state.

3.3.2.6 Muting Restart while transported goods are located in the muting area

If there are transported goods in the muting area when the power is switched on (after mains failure, emergency stops or muting sequence failure) a muting restart is required. In case of the conveyor system covers at least one muting sensor but not the sensing field of the AOPD to be muted, pressing and releasing the reset button activates the transporting system. Muting is not activated. As soon as the transported goods interrupt the sensing field of the AOPD to be muted, the OSSDs are switching into the OFF-state and the muting indication lamps start to blink. Muting restart is now possible. In case of the conveyor covers at least one muting sensor and, at the same time, the sensing field of the AOPD to be muted when power is switched on, the OSSDs stay in the OFF-position while the muting indication lamps are blinking. Muting restart is immediately possible. Muting

restart requires pressing the reset button two times within 4 s. On the second activation of the start button the OSSDs immediately are switching to the ON-state. On the second release of the start button the MSI-m(E)/R safety interface checks the muting sensors for a valid state. If the check ascertains a normal condition of the muting sensors, the OSSDs will stay in the ON-state. The system takes on normal conditions.



If an invalid combination is detected, the release remains in effect only as long as the start button continues to be pressed. As soon as the button is released, the system comes to a standstill. Thus it is possible to enable and operate the system as long as a responsible person constantly observes the process and can interrupt the dangerous movement at any time by letting go of the start button. In this case, the muting sensors have to be checked for misalignment, contamination or damage. This option assumes that the start button, as stated in the safety precautions (Chapter 2.6) is mounted in a location from which the entire danger zone can be viewed.

3.3.2.7 10-Minute Muting Time-Limit

Regardless of the selected muting mode, the MSI safety interface reports a muting malfunction when the duration of a muting state exceeds 10 minutes.



The muting time limit is mandatory. The muting time limit may only be switched off with DIP switch MU2 in the I/O-m module in well-grounded cases, e.g. for a normally uninterrupted flow of goods in the muting path and if no persons are thereby endangered.



Warning!

The user assumes responsibility for switching off the muting time monitoring!

3.3.2.8 Example: Sequential Muting with Non-Testable Muting Sensors

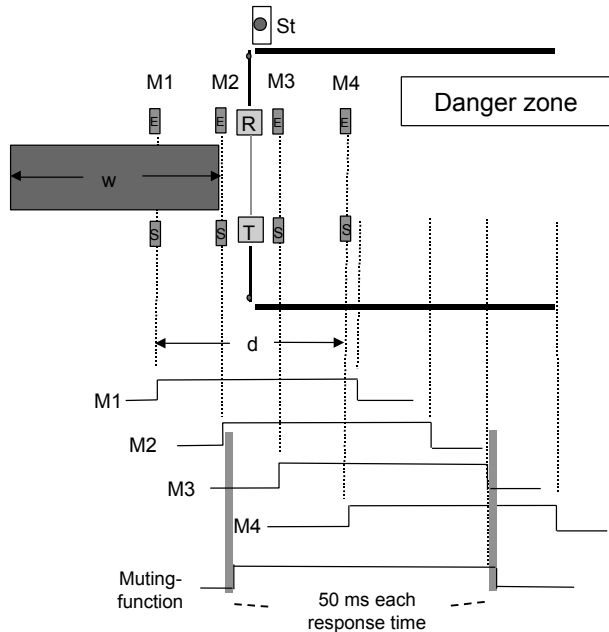

- Caution: Non-testable muting sensors. Shift DIP switch MU3 to the „up“ position.
- Muting function effects the inputs S1 & S2 (factory setting). Put up DIP switch MU4, if the input S2 should not be muted. See Chapter 3.2.2 DIP switch setting I/O-m module.

T = AOPD transmitter

R = AOPD receiver

St = Start/restart, muting restart, must not be reachable out from the danger zone

- M1 to M4, non-testable muting sensors through-beam principle, deliver 24 V DC in damped state
- Sequential activation without time monitoring. But: 10 min. Time-limit when muting has started
- w = conveyor length, d = distance M1, M4, Condition: $w > d$
- M2 and M3 close to the AOPD, but 50 ms response time to be considered
- M1 to M4, symmetrical arrangement
- All muting sensors must be deactivated, before a new muting cycle can be started in any direction.

3.3.2.9 Example: Sequential Muting with Testable Muting Sensors

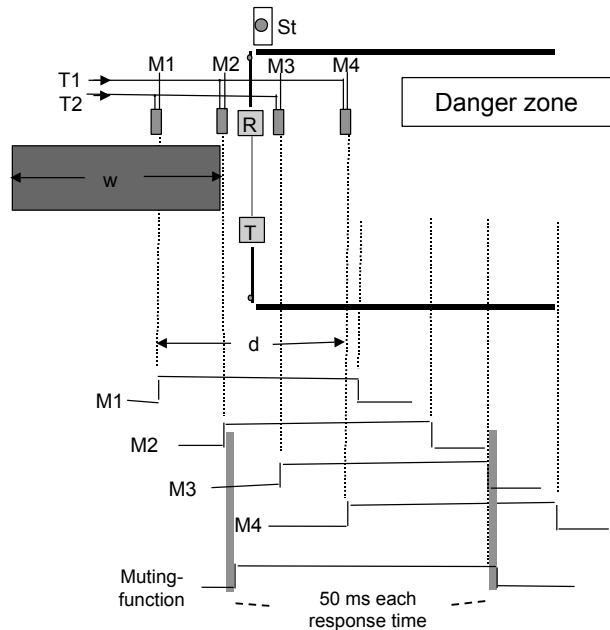

- Caution: Testable muting sensors. DIP switch MU3 „down“ position (factory setting)
- Muting function effects the inputs S1 & S2 (factory setting). Put up DIP switch MU4, if the input S2 should not be muted. See Chapter 3.2.2 DIP switch setting I/O-m module.

T = AOPD transmitter

R = AOPD receiver

St = Start/restart, muting restart, must not be reachable out from the danger zone

- T1, T2 test signal outputs
- M1 to M4, testable muting sensors scanning principle, provide 24 V DC in damped state
- Sequential activation without time monitoring. But: 10 min. Time-limit when muting has started
- w = conveyor length, d = distance M1, M4, Condition: $w > d$
- Positioning of M2 and M3 as close as possible to the AOPD, but consider 50 ms response time
- M1 to M4, symmetrical arrangement
- All muting sensors must be deactivated, before a new muting cycle can start in any direction.

3.3.2.10 Example: Parallel Muting (2.5 s) with Non-Testable Muting Sensors

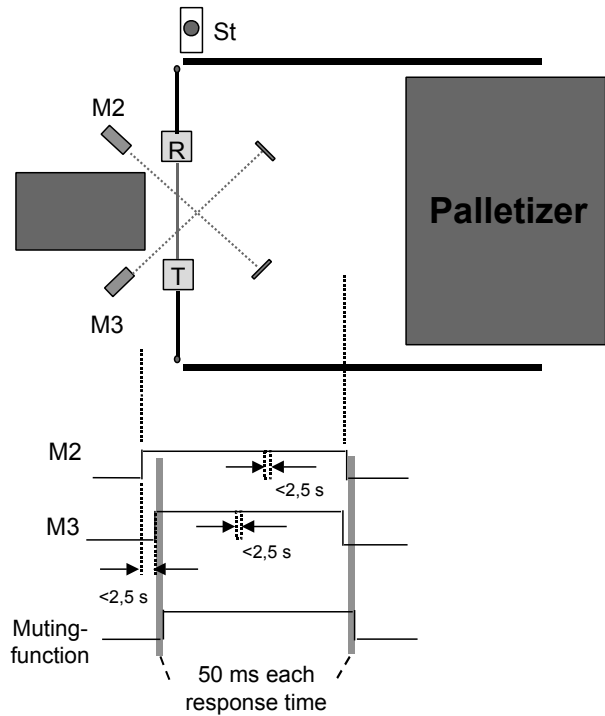

- Caution: Non-testable muting sensors. Shift DIP switch MU3 to the „up“ position.
 - Muting function effects the inputs S1 & S2 (factory setting). Put up DIP switch MU4, if the input S2 should not be muted. See Chapter 3.2.2 DIP switch setting I/O-m module.
- T = AOPD transmitter
R = AOPD receiver
St = Start/restart, muting restart, must not be reachable out from the danger zone
- M2 and M3 = non-testable muting sensors
 - The two retro-reflective light barriers, dark-switching, with pnp output provide 24 V DC in damped state
 - Condition: Simultaneous activation of M2 and M3 within 2.5 s
 - Muting function is limited to 10 min. (muting time-limit)
 - Short interruptions of less than 2.5 s do not stop the muting function as long as only one muting sensor is deactivated.
 - As soon as both of the muting sensors are falling back to 0 V, the muting function will end.
 - Caution: The two muting sensors beams must intersect behind the protective field of the AOPD, i.e. within the danger zone. Symmetrical arrangement.

3.3.2.11 Example: Parallel Muting (2.5 s) with Testable Muting Sensors

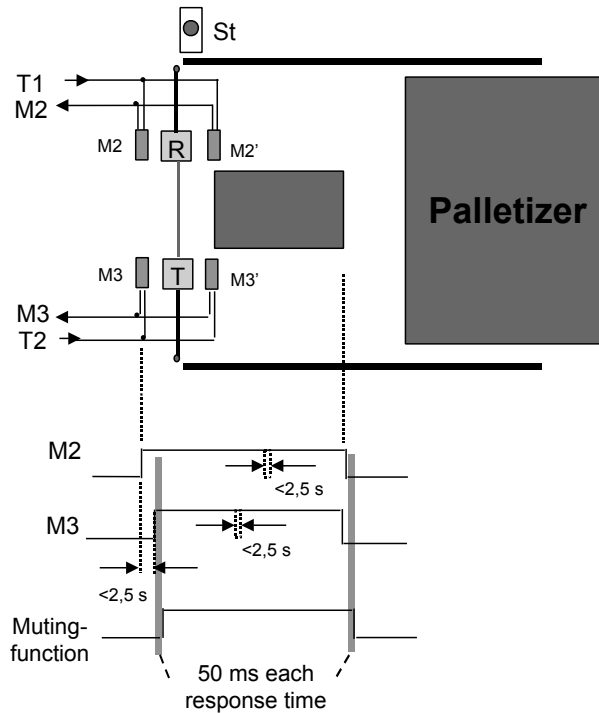

- Caution: Testable muting sensors. DIP switch MU3 „down“ position (factory setting)
- Muting function effects the inputs S1 & S2 (factory setting). Put up DIP switch MU4, if the input S2 should not be muted. See Chapter 3.2.2 DIP switch setting I/O-m module.

T = AOPD transmitter

R = AOPD receiver

St = Start/restart, muting restart, must not be reachable out from the danger zone

- T1, T2 test signal outputs
- M2 and M3, M2' and M3' = Testable Muting Sensors
- The four reflective light scanners, light-switching, with pnp output provide 24 V DC in damped state.
- Condition: Simultaneous activation of M2 and M3 or M2' and M3' within 2.5 s
- Muting function is limited to 10 min. (muting time-limit)
- Short interruptions of less than 2.5 s do not stop the muting function as long as only one muting sensor is deactivated.
- As soon as both of the muting sensors are falling back to 0 V, the muting function will end.

- M2, M2', M3 and M3' should be mounted as near as possible to the protective field, but the response time

of 50 ms must be considered. Symmetrical arrangement.

3.4 Displays

A number of LEDs of various colors indicate the operating status of the MSI modular safety interface. It is also possible to show the LED displays on the PC monitor

using the integrated RS 232 interface and diagnosis connector.

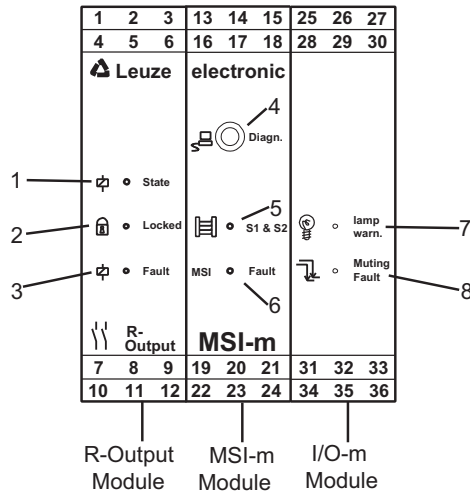

Output /R					
Position	Display/Function	Symbol	Status	LED	Color
1	not applicable	–	–	–	–
2	Safety-related switch output	relay	on off	on on	green red

3	Start/restart interlock	lock	locked not locked	on off	yellow
4	Fault in output module	relay	fault no fault	on off	red

MSI-m Module					
Position	Display/Function	Symbol	Status	LED	Color
5	Diagnosis, RS 232 See status outputs	jack diagn.	none	none	
6	not applicable	–	–	–	–
7	Protected field	AOPDs S1 & S2	protected field free not free	on off	green
8	MSI fault	MSI Fault	fault no fault	on off	red

I/O-m Module					
Position	Display/Function	Symbol	Status	LED	Color
9	not applicable	–	–	–	–
10	not applicable	–	–	–	–
11	Muting indicator	broken filament short circuit interruption	defect indicator 1 defect indicator 2 no defect	blinks 1 x blinks 2 x off	red red
12	Muting failure	sequence error	failure no failure	on off	red

3.5 Status Outputs



Status outputs are not allowed to be used as safety-related signals in release circuits

(see also Chapter Safety. Operating Conditions and Proper Use).

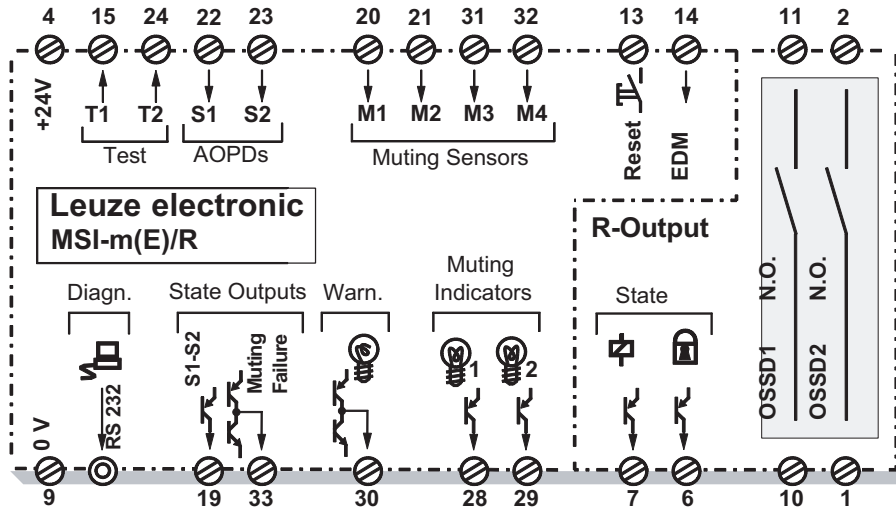

Output /R				
Terminal	Message Function	Symbol	Status	Status Output
6	Start/Restart interlock	lock	locked not locked	active high active low
7	Safety-related switch status	relay	ON OFF	active high active low

MSI-m Module				
Terminal	Message Function	Symbol	Status	Status Output
Front jack	Diagnosis, RS 232 2.5 mm round connector	–	–	connected to PC with diagnosis program
19	Protected field(s)	S1 - S2	free not (all) free	active high active low

I/O-m Module				
Terminal	Message Function	Symbol	Status	Status Output
28	Muting indicator 24 V DC, 5 W max.	lamp	muting on muting off	active high active low
29	Muting indicator 24 V DC, 5 W max.	lamp	muting on muting off	active high active low
30	Warning Muting indicator defective	broken filament short circuit interruption	indicator OK defect indicator 1 defect indicator 2	active high impulse 1x impulse 2x
33	Muting failure	Muting Failure	no failure muting failure	active high active low

3.6 Diagnosis System

Requirements for running the diagnosis system: a standard PC or laptop operating under Windows (Version 3.1 or higher) and the MSI software, Version 01, as well as a serial connection cable and a 2.5 mm jack plug.

- Simultaneous display of all input and output statuses as well as all LED displays on the MSI

With its diagnosis interface, the intelligent modular safety interface MSI offers a convenient way to visualize all of

the input and output statuses simultaneously on the monitor.

The connection circuit diagram as well as display fields in different colors can be shown on the screen via the connection terminals. A graphic representation of the MSI front design with the display elements as described in Chapter 3.4 also appears on the screen.

Example:

1	2	3	13	14	15	25	26	27
4	5	6	16	17	18	28	29	30

Prog. version:	0.00	restart-interlock:	without
S1:	n.c.	EDM - mode:	dynamic
S2:	n.c.	EDM:	without
S3:	n.c.	relay prewarning:	100k
S4:	n.c.	relay zyklen:	0k
ME1:	n.c.	start test emulation:	no
ME2:	n.c.	time monitoring:	without
ME3:	n.c.	muting sensor test:	without
ME4:	n.c.	muting timeout:	without
SS1a:	n.c.	muting mode:	Leuze
SS1b:	n.c.		
SS2a:	n.c.		
SS2b:	n.c.		

COM1 | Klemmen- und LED-Farben: rot = 0V, grün = 24V, gelb = hochohmig

Start | Pronto E-Mail | Diagnose-Programm...

09:48

This enables the sequences at individual screw-type terminals to be tracked without the use of additional measuring instruments. The diagnosis function is equip-

ped with on-line help and can be operated in either English or German.

4 Electrical Connection

4.1 Installation Regulations



The general safety precautions must be observed. The electrical installation may be performed only if there is no voltage applied, and it must be performed by trained specialists.



In the /R versions, it is possible that high voltages may be present at the output contacts. A no-voltage state is achieved only when the 24 V DC supply voltage as well as the supply lines to the switch contacts are safely

4.2 Power Supply Requirements



The supply voltage of 24 V DC must guarantee safe mains separation and be able to bridge an interruption in voltage of 20 ms at full load. The functional earth connection of the MSI is established when snapped onto

4.3 Connecting AOPDs, Type 4 or Type 2

The examples below show possibilities for connecting and combining AOPDs of various safety categories and with various output features (relays, safety-oriented transistor outputs, cross circuit monitoring within and outside the AOPD).

AOPDs Type 4 with transistor outputs and cross connection monitoring function can directly connected to the safety inputs S1 and S2. See Example 1.

switched off and secured against being switched on again.



Coded plug-in terminal blocks allow a connection cross-section of up to 2.5 mm². The supply voltage must be externally fused against excess current with a fuse of 2.5 AmT. The switch contacts must also be externally fused against excess current with a maximum of 4A gG. This prevents the safety-related contacts from welding together if the current load is too high!

the grounded metal mounting rail via the rear clamp fixture.

The lead for the supply voltage must be externally fused against excess current with a maximum of 2.5 AmT.

AOPDs Type 4 with relay outputs must be connected so that the odd-numbered test signal T1 are directed via the non-delaying contacts to an odd-numbered safety input (T1=>S1) and vice versa (T2=>S2). See Example 2.

AOPDs Type 2 are periodically tested using the time-displaced test signals T1 or T2. The odd-numbered test signal must be directed to an even-numbered safety input by the way of the time-delaying AOPD (T1=>S2)

and vice versa ($T2 \Rightarrow S1$). The AOPD response time to a test request must be in a range of 2 to 18 ms. See Example 3.

All available safety inputs must be occupied! In case no components are connected, the remaining inputs must be connected to the corresponding test signal using bridges. In doing so, please note that the odd-numbered test signal must be connected to the odd-

numbered safety input via the non-delaying bridge ($T1 \Rightarrow S1$) and vice versa ($T2 \Rightarrow S2$). See Example 4.

If type 2 AOPDs are connected:

- according to DIN EN IEC 61496-1, only a maximum of PL c or SIL CL 1 can be achieved!
- when cables are laid without protection, a failure detection time of up to 10 s is possible.

Example 1

1 AOPD Typ 4 with 2 safety-related transistor outputs and internal cross connection monitoring function.

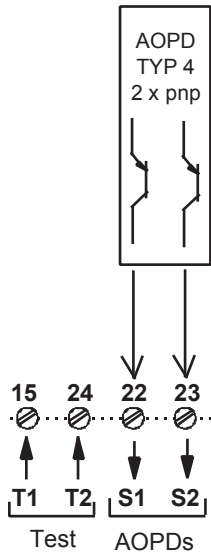

Example 2

1 AOPD Typ 4 with 2 normally open relay contacts. Cross connection monitoring by using the test signals T1 and T2.

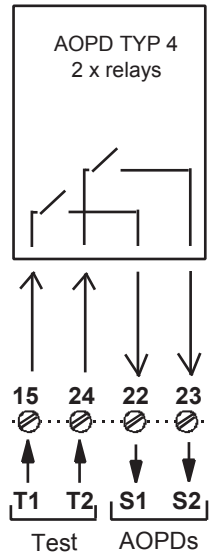

Example 3

2 AOPDs Type 2 with one safety-related transistor output each. Cross connection between the leads will be detected.

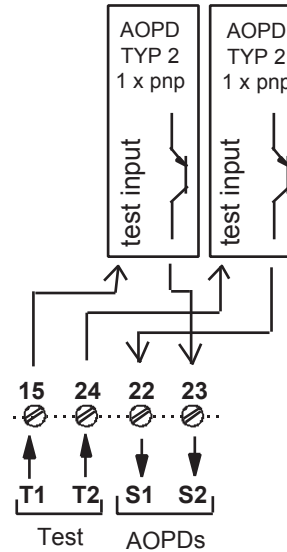

Example 4

1 AOPD Type 2 with one safety-related transistor output.

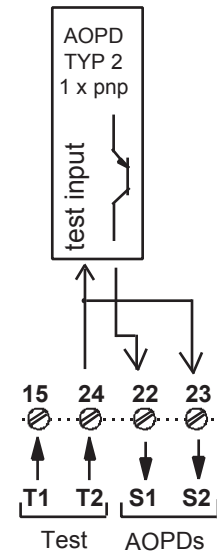

4.4 Connecting Machine Controls



The safety-related parts of the controls comprise more than the MSI-m(E)/R described above. They also include successive control elements and even power transmission elements which must be safely and promptly shut down. Particular attention must be paid to maintaining the safety category requirements. Important information in this regard can be found in the harmonized European standard DIN EN ISO 13849-1.



Essential prerequisites for safe operation are the abilities to electrically influence the interruption of the dangerous movement and to bring the machine to a standstill as quickly as possible. These factors, as well as the response times of AOPDs and the MSI, must be taken into consideration when calculating the safety distance.

The response times depend on the type of AOPD selected (see Chapter 6, Technical Data). Other parameters, such as hand/arm/body approach speed or additional safety distance, depend on the particular application and the resolution of the AOPD being used. The European standard DIN EN ISO 13855 contains equations and examples for a variety of configurations.



Warning!
Impairment of the protective function due to faulty muting signals with 2-sensor parallel muting!

Note the order of the ground connections! The ground connection of MSI-m (0 V / terminal 9) must be wired between the ground connections of muting sensors M2 and M3. For the muting sensors and the safety sensor, a shared power supply unit is to be used. The connection lines of the muting sensors must be laid separated from one another and protected.

5 Connection Circuit Diagram, Examples

The connection example below shows one wiring suggestion each for the MSI-m(E)/R

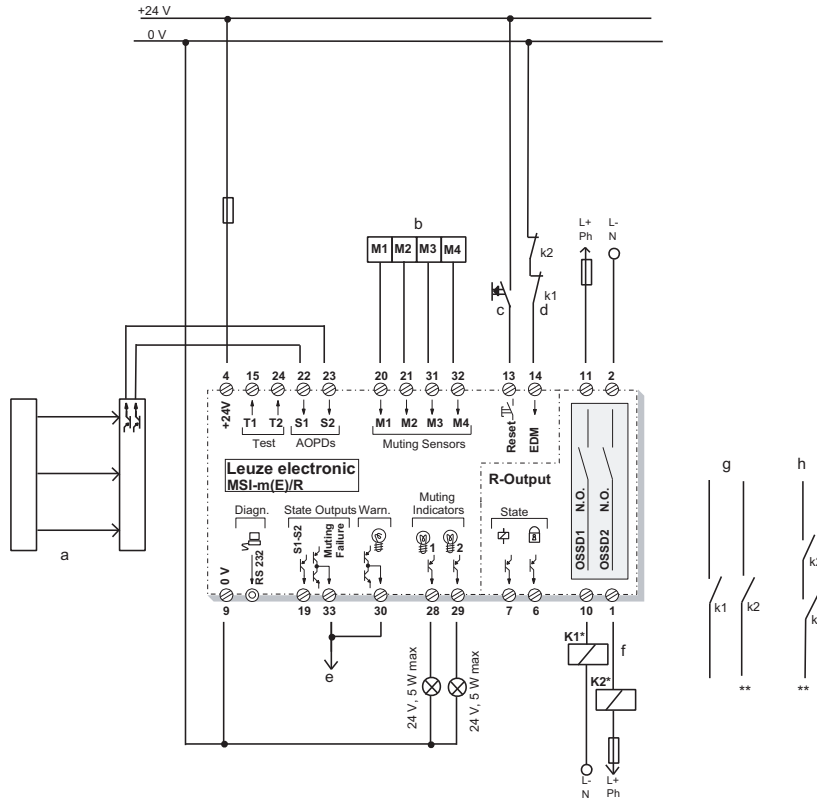

Connection example MSI-m(E)/R with one AOPD Type 4

- a = AOPD Type 4 with guarding and muting function
- b = M1, M2, M3, M4, Non-testable muting sensors (i.e. through-beam, dark switching), sequential muting mode
- c = Command device for releasing the start/restart interlock
- d = Feedback loop for external device monitoring
- e = Possible collective output for warning/error indications
- PIN 19 = Indicating output "sensor status"
- PIN 33 = Indicating output "muting failure"
- PIN 30 = Warning output "Muting indicator defective"
- PIN 28/29 = Output Muting indicators 1 and 2
- PIN 7 = Indicating output "status safety outputs"
- PIN 6 = Indicating output "status start/restart interlock"
- f = Output Signal Switching Devices (OSSDs)
- g = Switching off path with two-channel control
- h = Switching off path with one-channel control
- * = Suitable spark suppression required
- ** = In general, both of the OSSDs must be used in the subsequent machine control path. Use relays or contractors with positive-driven contacts only.

All available safety inputs must be occupied!

See Chapter 4.3.

6 Technical Data and Ordering Information

6.1 MSI-m(E)/R

Version, Type Modular Safety Interface	MSI-m(E)/R	
Type in accordance with DIN EN IEC 61496-1	Type 4	
SIL in accordance with IEC 61508	SIL 3	
Performance Level (PL) in accordance with DIN EN ISO 13849-1	PL e	
Category in accordance with DIN EN ISO 13849-1	Cat. 4	
Mean probability of a dangerous failure per hour (PFH _d) as a function of the mean number of annual switching cycles of the relay n _{op} *	100% Load n _{op} = 4.800: 1,5 x 10 ⁻⁰⁸ 1/h 60% Load n _{op} = 4.800: 1,2 x 10 ⁻⁰⁸ 1/h 100% Load n _{op} = 28.800: 3,1 x 10 ⁻⁰⁸ 1/h 60% Load n _{op} = 28.800: 1,5 x 10 ⁻⁰⁸ 1/h 100% Load n _{op} = 86.400: 7,4 x 10 ⁻⁰⁸ 1/h 60% Load n _{op} = 86.400: 2,1 x 10 ⁻⁰⁸ 1/h	
Number of cycles until 10 % of the components have a failure to danger (B _{10d})	400,000: 100% of the max. switched current of loading cases AC1..DC13 2,500,000: 60% of the max. switched current of loading cases AC1..DC13 20,000,000: 60% of the max. switched current of loading cases AC1..DC13	
Service life (T _M)	20 years	
Connectable safety sensors S1 and S2	1 AOPD, Type 4, Type 3 or up to 2 AOPDs, Type 2 (all in accordance with DIN EN IEC 61496-1)	
Test outputs T1 and T2, Test interval Test impulses, time-displaced Response time AOPD Type 2 to a test request	200 ms 24 ms each 2 to 18 ms	
Available functions	Start/restart interlock External device monitoring Sequential muting Parallel muting (2.5 s)	

Control input Start/restart interlock (Reset)	Potential-free normal open contact (button or key button)
Control input External device monitoring (EDM)	Feedback of positive-guided contacts from downstream relays (see connection diagram)
Control inputs Muting sensors M1 to M4 (separate connection cables required) Connection of non-testable muting sensors Connection of testable muting sensors Response time of testable muting sensors to a test request	Signal level in damped state: active high, 24 V DC active low, 24 V DC, plus test impulses from T1 or T2 2 to 18 ms
Muting displays for lamps 24 V DC/ 5 W max. LED indicators 24 V DC, 0,5 W to 5 W	pnp – semiconductor output Muting function on active high, 24 V DC, 200 mA max. Muting function off active low
Status outputs Status protected fields S1 and S2	pnp – semiconductor output All protected fields free active high, 24 V DC, 60 mA max. not free active low
Status outputs MSI fault, Muting failure	Push-pull transistor outputs, each No fault message active high, 24 V DC, 60 mA max. Fault message active low
Warning output Muting indicator defective	Push-pull transistor output No warning active high, 24 V DC, 60 mA max. Fault message indicator 1 impulse 1x Fault message indicator 2 impulse 2x
Safety outputs (Technical Data, see below)	Relay outputs via /R-Output
Supply voltage	24 V DC, $\pm 20\%$, external power supply (PELV) with safe mains separation and equalization for 20 ms voltage interruption required
Current consumption	approx. 200 mA without external load
External fusing	2.5 A
Housing Enclosure rating	IP 20; must be installed in electronics cabinet or housing with an enclosure rating of at least IP 54 Mounting at 35 mm DIN standard rail
Protective class	II

Ambient temperature, Operation	0 ... + 55 °C
Ambient temperature, Storage	-25 ... + 70 °C
Relative humidity	93 % max.
Connection type (GS-ET-20: 2014)	pluggable, coded screw-type terminals Cable cross-section min., rigid, flexible: 0.14 mm ² Cable cross-section max., rigid, flexible: 2.5 mm ² Cable cross-section AWG/kcmil, min./max.: 26/14 Cable cross-section UL AWG/kcmil: 30-12
Dimensions	See dimensional drawing
<p>*n_{op} = mean number of annual actuations, see C.4.2 and C.4.3 of DIN EN ISO 13849-1</p> <p>Use the following formula to calculate the mean number of annual actuations:</p> $n_{op} = (d_{op} \cdot h_{op} \cdot 3600 \text{ s/h}) \div t_{Zyklus}$ <p>In doing so, make the following assumptions with regard to the use of the component:</p> <p>h_{op} = mean operating time in hours per day d_{op} = mean operating time in days per year t_{Zyklus} = mean time between the start of two successive cycles of the component (e.g switching of a valve) in seconds per cycle</p>	

6.2 /R-Output

OSSD safety outputs switching voltage/switching current	2 safety-related normal open contacts 60 V DC, 250 V AC, 5 A max. Minimum switching current 20 mA
OSSD external fusing (EN 60269-1)	4A gG D-fuse
Contact currents (IEC EN 60947-5-1)	AC15, 3A DC13, 2A
OSSD response time MSI (without AOPD)	for AOPD Type 4, transistor outputs 22 ms for AOPD Type 4, relay outputs 64 ms for AOPD Type 2 64 ms for safety switches (electro mechanical) 64 ms
OSSD reset time	100 ms
OSSD suitable spark extinguishing over the coils of the downstream relays	Required
Status output "Status switch outputs" not to be used for safety circuit! 	pnp output OSSDs ON-state: active high, 24 V DC, 60 mA max. OSSDs OFF-state: active low
Status output "Status start/restart interlock"	pnp output locked: active high, 24 V DC, 60 mA max. not locked: active low

6.3 Dimensional Drawing

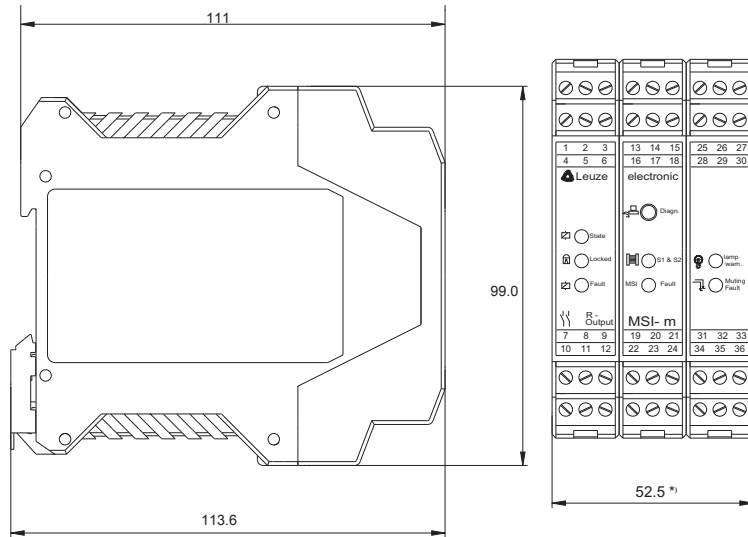

*) Stringing together without distance possible

6.4 Ordering Information

Type	Part No.
MSI-m/R	549904
MSI-mE/R	549980
MSI Diagnosis software	549930
diagnosis cable 3 m	549953
diagnosis cable 5 m	549955
/R output subassembly (replacement part)	509210

