

the **sensor** people

visionPOWERBOX

Industrial image processing today
can be this easy and this flexible



Modern processes require **efficient** and **flexible** solutions.

More cost effective through PC-based image processing.

Modern production involves a multitude of tasks. Beginning with correct material flow and including everything from monitoring process steps to quality assurance, these tasks increasingly demand the use of suitable image processing systems. While vision sensors are used increasingly for simple tasks, complex tasks in which exact results and flexibility are essential demand vision systems or high-performance smart cameras.

Systems such as the *visionPOWERBOX* are able to reliably perform inspections even at high cycle rates and store results or fault images and, unlike vision sensors, do so without restrictions in the number of test programs to be stored. Furthermore, some of the components can also be selected for specific applications in order to optimally adapt the system to the individual needs. Integrated interfaces, such as Ethernet, RS 232 and digital inputs/outputs for fast integration of the systems in an industrial environment, round out the features.

The included software package with many useful tools and extremely user-friendly user interfaces facilitates quick setup of inspection tasks and efficient processing of image data. The software also provides helpful support when creating test programs for product variants, as it is possible to access saved inspection routines. Configuration is interactive and takes place via the familiar Windows interface with mouse clicks and configuration settings.



Advantages of the *visionPOWERBOX*.

- Extensive software package with high-performance and robust image processing tool offers flexibility for numerous applications.
- High computing power and the accustomed, simple, Windows-based operation of the computer (Windows XP).
- Fast image capture: up to 58 full images/s (VGA resolution) enables use for fast processes and high cycle rates.
- Compact camera construction enables installation even in tight spaces.
- Multi-camera system for synchronous or serial image capture.
- Serial interfaces, Ethernet and digital, opto-decoupled inputs and outputs (16 of each) for simple connection to production lines.
- Large selection of accessories, such as objectives and illumination, for nearly every application.



visionPOWERBOX

Flexible, high-performance and communicative.

Systematic image processing through matched components and high-performance software tools.

The *visionPOWERBOX* is a compact-PC based image processing system with digital FireWire technology for trouble-free image capture and top-quality image transmission. The high bus transfer rate, high computing power, various camera types and an extensive software package with robust and reliable image processing tools enable flexible use of the system in a wide range of applications.

The *visionPOWERBOX* convinces with its simple operation and can be quickly and economically integrated in production lines. As a multi-camera system, it is the ideal solution for medium to complex tasks in automation, process control, quality inspections or in identification.



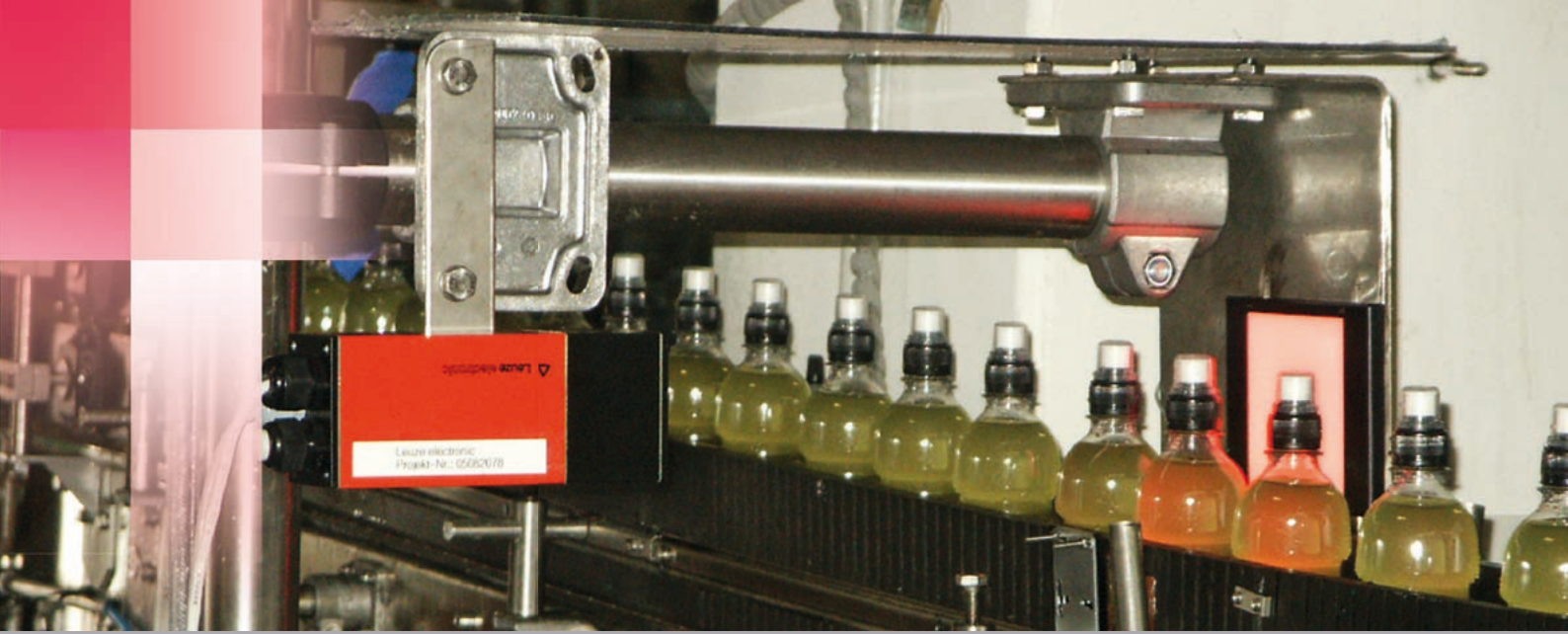

Optional accessories round out the system.

In addition to the basic package, we also offer our customer extensive accessories that they can use to adapt the system to their individual requirements.

Basic package

- Compact-PC
- VGA camera
- 10 m camera cable
- Digital I/O card
- Keyboard
- Mouse
- High-performance image-processing software

Optionally available accessories

- Cable
- Objectives (for IR-VIS-UV, telecentric objectives, etc.)
- Illumination (LED, RF, ...)
- Protective housing

Character reading



Defect monitoring

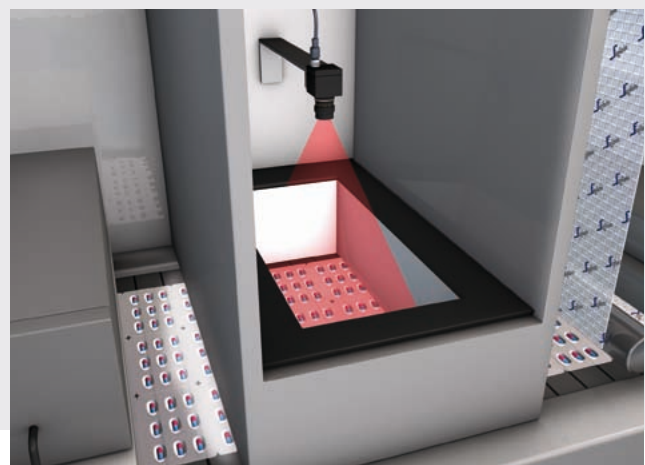

The **software** makes the **difference**.

The intuitive and easy-to-operate software package makes the system complete.

A key component that plays a defining role in the performance of an image processing system is the software. With the *visionPOWERBOX*, you receive a complete package with high-performance and easy-to-operate Windows XP based tools. These include applications that are only optionally available in other systems, such as contour detection or code reading of 1D codes or stacked codes.

In addition to the standard functions, such as measuring or BLOB for the presence, quantity or completeness inspections as well as colour or pattern detection and printout inspections, images can also be preprocessed with the software or the camera's field of view calibrated. Furthermore, overlays with important information can be created for the operator, statistical data captured and logical comparisons or other calculations performed on the basis of the inspection results.

Configuration Mode

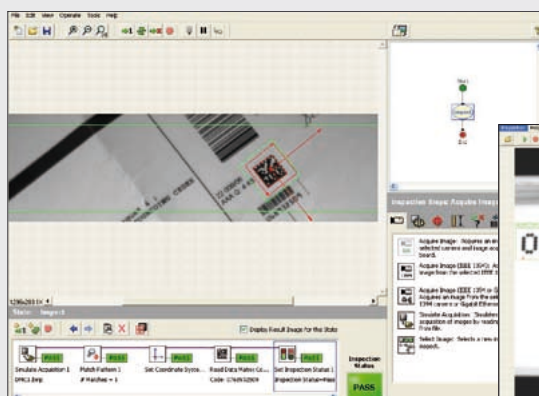

Inspection Mode

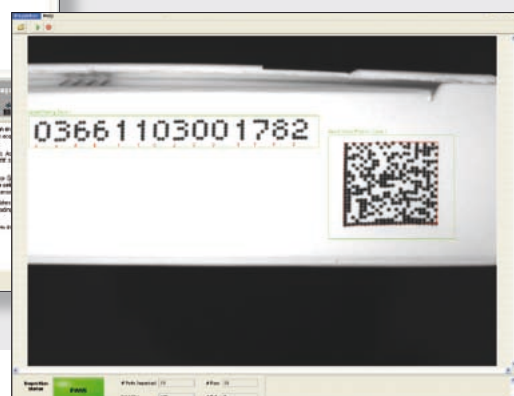

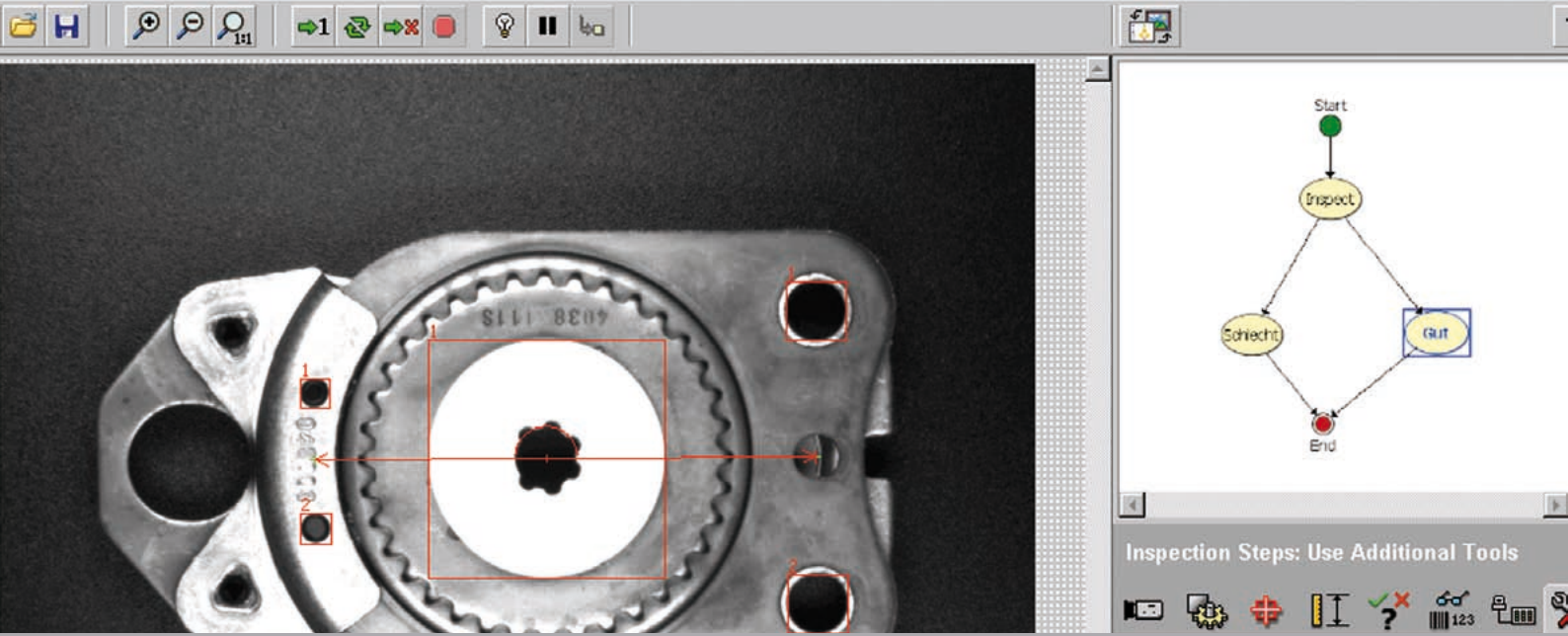

The “Configuration Screen” is used to set up a new test program or to make changes to existing programs. In addition to the image processing tools, other tools are available to the user here:

- **Setup:** This tool is used before beginning testing in order reach a specific action, e.g. hardware initialisation.
- **Status diagram:** This tool is used to create states graphically, e.g. how the system is to respond in case differentiations.
- **Select Inspection:** Tool for executing a program changeover – e.g. using a bit pattern at the digital inputs of the *visionPOWERBOX*.
- **Cleanup:** Tool for executing an action following an inspection, e.g. resetting the hardware settings to the default values.

The inspections themselves are performed in the so-called “Inspection Screen”, which makes available the key information of the inspection, such as:

- Inspection image
- Inspection results
- Statistical data (good/bad)
- Inspection time or capacity rating

Robust and reliable software tools for industrial image processing.

Various image processing tools:

- **Image preprocessing** such as linear and non-linear filters, FFT filter, colour transformations, reflection, rotation, inversion, etc.
- **Image field calibration**
- **BLOB:** For presence, quantity or completeness inspections (incl. simple applications such as pixel counting and intensity measurement).
- **Measure:** For high-contrast or noisy edges, for determining distances, midpoints, intersections, angle to horizontal, vertical and between lines, midlines, centres of gravity, area calculations, fitting best-fit lines or circles/ellipses.
- **Colour:** Simple colour inspection in RGB, HSL or CIE colour spaces (requires colour camera).
- **Pattern detection:** Area-based, geometry-based (scalable, with partial covering of the pattern) or colour pattern detection.
- **Printout inspection:** Detection of defects or deviations with respect to taught reference image ("golden" template). The template is scalable and can be corrected for perspective. Defects can be filtered according to many different parameters (orientation, centres of gravity, compactness, etc.).
- **Optical character reading:** Read or verify fonts, characters or symbols. Nearly all font types can be taught, incl. industry fonts such as OCR-A, OCR-B and SEMI.
- **1D-code reading:** Codabar, Code 39, 93 and 128, EAN 8 and 13, 2 of 5 Interleaved, MSI, UPCA, Pharmacode and RSS Limited (GS1 Databar).
- **Stacked codes:** PDF 417.
- **2D-code reading:** QR codes (standard or micro) and Data Matrix codes (ECC 000, 050, 080, 100, 140 and 200, incl. AIM verifier).
- Monitor output for the operator (overlays).
- Record statistical data, logistical comparisons and calculations.
- Save camera parameters (shutter time, gain, etc.), good/bad images and results.
- Optional remote maintenance

Specifications

PC				
Basic device	Compact-PC			
Processor	Intel Pentium			
Storage media	Hard disk, DVD drive			
Operating system	Windows XP			
Interfaces				
Cameras	FireWire (IEEE1394)			
Serial	2 x USB, 1 x serial, keyboard, mouse			
Digital inputs/outputs	16 of each (24VDC, opto-decoupled, max. 100 mA per output)			
LAN	Fast Ethernet (10/100Mbit/s)			
Video output	VGA (max. 1,600 x 1,200)			
Mechanical data				
Housing	Aluminium			
Dimensions (W x H x D)	180 x 200 x 280 mm ³			
Electrical data				
Operating voltage	230VAC			
Power consumption	300W (w/o options)			
Environmental data				
Operating temperature	0 °C ... 45 °C			
Air humidity	< 90 % (non-cond.)			
Cameras				
Image capture	Progressive scan, full-frame or partial scan			
Sensor type	CCD			
Model	LR-M	LR-C	HR-M	HR-C
Camera type	monochrome	colour	monochrome	colour
Resolution	656 x 494	656 x 494	1392 x 1040	1392 x 1040
Chip size	1/3"	1/3"	1/2"	1/2"
Maximum image rate	58	58	17	17

Take a **look** for yourself.

The *visionPOWERBOX* at **work**.

Application examples and tasks in industrial image processing.

- Label inspection in packaging technology
(placement, identification, character and code reading).
- Assembly inspection in the automobile industry or in mechanical engineering
(completeness, adherence to dimensions and alignment).
- Object identification and position in the automobile industry, robotics
or mounting/handling technology (pattern detection, position and angle
position).
- Quality inspection in production
(defects, dimensions).
- Colour and printout inspections.

Application examples



Image & object comparisons (printout inspection)



Colour inspection (cap inspection)



Identification (OCV, barcode, Data Matrix code)

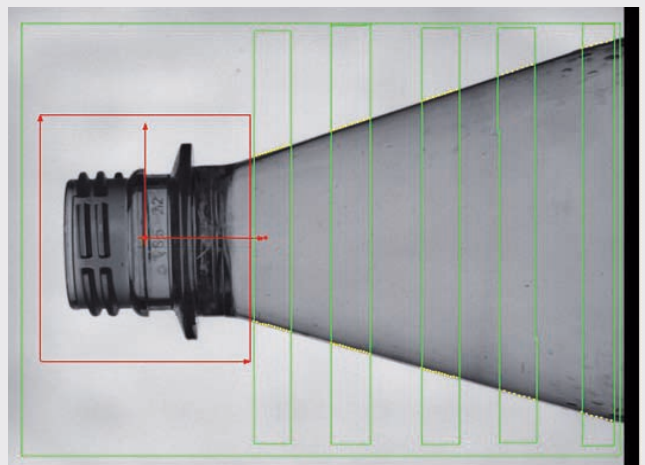

Dimension inspection/shape inspection

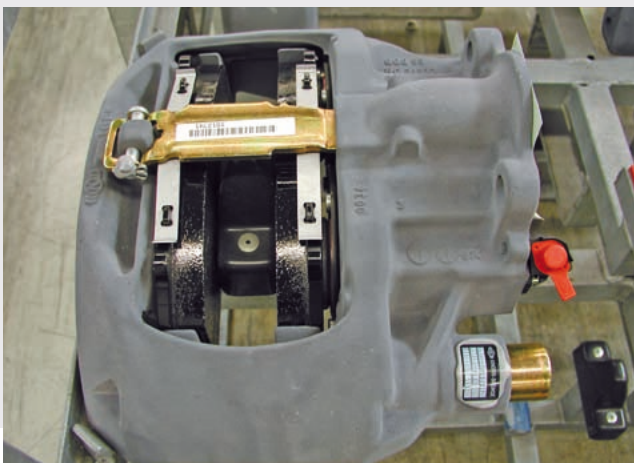

Presence/completeness inspection (assembly inspection)

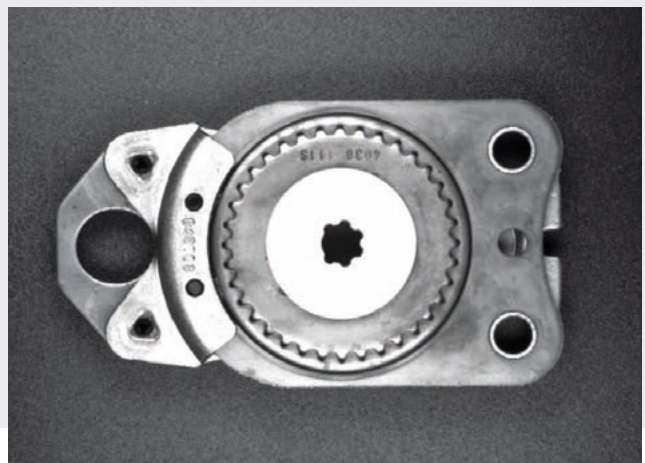

Position/orientation inspection (alignment inspection)

Optoelectronic Sensors

Cubic Series
Cylindrical Sensors, Mini Sensors, Fibre Optic Amplifiers
Measuring Sensors
Special Sensors
Light Curtains
Forked Sensors
Double Sheet Monitoring, Splice Detection
Accessories

Identification Systems

Data Transmission Systems

Distance Measurement

Barcode Readers
RF-IDent-Systems
Modular Interfacing Units
Industrial Image Processing Systems
Optical Data Transmission Systems
Optical Distance Measurement/Positioning
Hand-Held Readers

Safety Sensors

Safety Systems

Safety Services

Safety Laser Scanners
Safety Light Curtains
Transceivers and Multiple Light Beam Safety Devices
Single Light Beam Safety Devices
AS-i-Safety Product Range
Safety Sensor Technology for PROFIBUS DP
Safety Switches and Safety Locking Devices
Safety Relays and Safety Interfaces
Sensor Accessories and Signal Devices
Safety Engineering Software
Machine Safety Services

Leuze electronic GmbH + Co. KG

In der Braike 1

D-73277 Owen/Germany

Phone +49 (0) 7021 / 573-0

Fax +49 (0) 7021 / 573-199

info@leuze.de

www.leuze.com