

MSI-mi/R MSI-mi/T Modular Safety Interface



Notes on connection and operating instructions

These connecting and operating instructions contain information on the proper use of MSI Safety Interfaces in accordance with its intended purpose.



All the information contained herein, in particular the safety notes, need to be carefully observed.

Notes regarding safety and warnings are marked by this symbol .

These connecting and operating instructions must be stored carefully. It must be available for the entire operating time of the MSI Safety Interfaces.

The Leuze electronic GmbH + Co. KG is not liable for damages caused by improper use. Acquaintance with these instructions is an element of the knowledge required for proper use.

© Reprint and reproduction, in whole or in part, only with the explicit permission of

Leuze electronic GmbH + Co. KG
Liebigstrasse 4
82256 Fuerstenfeldbruck / Germany
Phone +49 8141 5350-0
Telefax +49 8141 5350-190
info@leuze.de
www.leuze.com

Table of contents: MSI-mi/R, MSI-mi/T

1	System Overview and Range of Applications	4	3.3.2	Guard Operation, Test Function	16
1.1	General Information	4	3.3.3	Cyclical Operation as Single Break or Double Break with Guard Function	16
1.2	Approvals	4	3.3.4	Muting Function	17
1.3	Terminology	5	3.3.4.1	Parallel Muting (0.5 s), Connections M2 and M3	17
1.4	Nomenclature MSI-mi/R and MSI-mi/T	6	3.3.4.2	Testable and Non-Testable Muting Sensors	17
2.1	Dangers if the safety notes are not observed	7	3.3.4.3	Muting Display Function	18
2.2	Operating Conditions and Proper Use	7	3.3.4.4	Start while muting sensors are activated	19
2.3	No EMERGENCY STOP button to be connected	9	3.3.4.5	10-Minute Muting Time-Limit	19
2.4	Additional Safety Precautions for the Special Function "Cyclical Control"	9	3.3.4.6	Example: Combination of Cycling and Muting Operation	20
2.5	Additional Safety Precautions for the Special Function "Muting"	9	3.4	Displays	22
3	System Configuration and Functions	10	3.5	Status Outputs	24
3.1	System Configuration	10	3.6	Diagnosis Function	25
3.2	DIP Switch Settings	10	4	Electrical Connection	27
3.2.1	DIP Switch Settings for the MSI-mi Module	10	4.1	Installation Regulations	27
3.2.2	DIP Switch Settings for the I/O-m Module	11	4.2	Power Supply Requirements	27
3.3	Operating Modes and Functions	12	4.3	Connecting AOPDs, Type 4 or Type 2	27
3.3.1	Operating Modes Interlocking Functions and External Device Monitoring	12	4.4	Connecting Machine Controls	30
3.3.1.1	Operating Mode: With Start/Restart Interlock – With Dynamic External Device Monitoring	13	6	Technical Data and Ordering Information	35
3.3.1.2	Operating Mode: With Start/Restart Interlock – With Static External Device Monitoring	14	6.1	MSI-mi/R, MSI-mi/T	35
3.3.1.3	Operating Mode: With Start/Restart Interlock – Without External Device Monitoring	14	6.2	/R-Output	37
3.3.1.4	Operating Mode: Without Start/Restart Interlock – Without External Device Monitoring	15	6.3	/T-Output	38
3.3.1.5	Operating Mode: With Start/Without Restart Interlock – Without External Device Monitoring	15	6.4	Dimensional Drawing	39
			6.5	Ordering Information	39
			7	Declaration of Conformity	40

1 System Overview and Range of Applications

1.1 General Information

The Modular Safety Interface (MSI) serves as a link between one or more active optoelectronic protective devices (AOPD), Type 2, Type 3 or Type 4, and the machine controls. All MSI safety components include start/restart interlock and external device monitoring functions that can be activated and deactivated. They are also equipped with a series of status outputs and LED displays as well as a diagnosis interface to a PC.

In addition, MSI-mi/R and MSI-mi/T offer a selection between guard only operation and cyclical operation.

1.2 Approvals

Europe	North America
Type Examination in accordance with EN IEC 61496, section 1 B I A Berufsgenossenschaftliches Institut für Arbeitssicherheit (Trade Association Institute for Industrial Safety) 53757 Sankt Augustin Germany	UL and C(UL) Approval pending

During cyclical operation, the machine is controlled by means of the interruption and subsequent release of the protected field. It is also possible to use the muting function to suppress the protective function of an AOPD, e.g. during the return motion of the tool, if no danger is caused by this movement. Special safety regulations for cyclical operation and muting are described in Chapter 2.4 and 2.5 below.

All MSI safety components are available with either relay outputs or with safety-oriented pnp transistor outputs.

1.3 Terminology

AOPD	Active Optoelectronic Protective Device
Clear	Clearance of Cycles, Test
Diagn.	Diagnosis Function
EDM	External Device Monitoring
ESPE	Electro-sensitive Protecting Equipment
Fault	Relay Fault
I/O-m Module	Muting Input/Output Module
Lamp Warn.	Muting Indicators Failure Warning
Locked	Start/Restart Interlock active
M2, M3	Muting Input 2, 3
N.O.	Normal Open Contact

OSSD	Safety-Related Switching Output
Reset	Start/Restart Interlock Initiator
RS 232	Interface RS 232
S1 - S2	Safety input 1, 2
S1 & S2	Indication protected fields free/interrupted
Select	Selection of Cycling Operation
Test	Test Signal Outputs
T1, T2	Test signal output 1, 2
Warn. (I/O-m Module)	Warning: Muting Indicator defective

1.4 Nomenclature MSI-mi/R and MSI-mi/T

MSI	Modular Safety Interface
m	with muting function
i	with modes of operation Guard only, Single break or Double break this version offers the following standard functions for either 1 AOPD, Type 4, or up to 2 AOPDs, Type 2: <ul style="list-style-type: none">– start/restart interlock– External device monitoring– Diagnosis function and the following special functions for 1 AOPD Type 4 or 1 AOPD Type 2: <ul style="list-style-type: none">– Cyclical operation– Parallel muting (0.5 s)– Displays and status outputs for guard, cyclical and muting operation
/R	Relay output: <ul style="list-style-type: none">– two normal open safety contacts, OSSD 1 and OSSD 2
/T	Transistor output: <ul style="list-style-type: none">– two safety-oriented pnp transistor outputs, OSSD 1 and OSSD 2

2 Safety Precautions



2.1 Dangers if the safety notes are not observed

Leuze electronics products and manufactured with stringent application of recognized technical regulations. The protective function of these devices can, however, be impaired if the devices are not used in accordance with

2.2 Operating Conditions and Proper Use

The applicable requirements for machine safety apply when using the Modular Safety Interface. The following are particularly applicable in the European Union:

- Machine Directive 98/37/EC and
- Machine Utilization Directive 89/655/EWG

as well as the corresponding applicable national regulations in the individual member states.

It is the responsibility of the manufacturer and the operator of the machine or equipment on which the protective device is installed to comply with these rules and regulations. The local authorities in charge (e.g. health and safety at work authorities) are available to answer questions concerning safety. The following conditions for use must be complied with:

- ?? The installation, electrical connection and parameterization of the protective device, and the required test before startup and regular tests must only be carried out by specialist personnel specifically commissioned for this purpose and the results must be transparently

their intended purpose. Such instances can jeopardize the health and lives of the personnel operating the machinery and/or may cause damage to property.

documented. Knowledge of the safety notes in these connecting and operating instructions is a constituent part of this competence.

- The safe function of the protective device must be checked before the startup and after every parameter change.
- The operating instructions must be included with the documentation of the machine on which the protective device is installed so that they are available for the operator at all times. The owner/provider of the machinery must ensure that the operator is instructed by an experienced specialist.
- Depending on the external cabling, the switch outputs can have dangerously high voltages. Before any work is done on the MSI safety interface, these outputs as well as the supply voltage must be switched off and safeguarded against being switched on again.
- The MSI is designed to be installed in an electronics cabinet or in a protective housing with an enclosure rating of at least IP 54.

- The supply voltage of 24 V DC \pm 20% must exhibit a safe mains separation and be able to bridge brief power outages of 20 ms.
- The MSI fulfills the requirements of Safety Category 4 in accordance with EN 954-1. However, if an AOPD from a lower safety category is connected, the overall category for that path of the controls cannot be higher than that of the connected AOPD.
- As a rule, at least two switch contacts or safety-related pnp transistor outputs must be connected into the switch-off circuit of the machine. In order to prevent the relay switch contacts from welding together, they must be externally fused as specified in the Technical Data, Chapter 6.
- It is not allowed to use status outputs to switch safety-related signals.
- Cross circuits between S1 and S2 are detected by the MSI safety component only if the two time-displaced test signal outputs T1 and T2 are used for the connected AOPD(s) with relay outputs. Type 4 AOPDs with safety-related transistor outputs and their own cross circuit monitoring can be connected directly to S1 and S2.
- The "Reset" button for resuming operation following a start/restart interlock must be placed in a location from which the entire danger area can be clearly watched.
- The safety distance between the AOPD and the danger point must be maintained. It is calculated according to the formulas in the specific machine-related C-Standards or in the general B1 Standard EN 999. The response time of the MSI (Chapter 6, Technical Data), the response time of the protective device, and the stopping time of the machine must all be taken into consideration when calculating the safety distance.
- AOPDs are not suitable in applications where a danger of throwing out pieces or splashing out hot or dangerous liquids exists. Also they are not suitable for machines with extended stopping times. For these or similar applications Leuze electronic offers mechanical interlocking devices with or without guard locking.

2.3 No EMERGENCY STOP button to be connected

- It must be secured that the EMERGENCY STOP function is always and immediate effective. EMERGENCY STOP buttons must not be connected at sensor inputs which provide for muting or cycling control functions. Since MSI-mi does not provide for

additional sensor inputs without special functions, no EMERGENCY STOP buttons must be connected. If an EMERGENCY STOP button is needed, the use of the extended version MSI-mix is recommended.

2.4 Additional Safety Precautions for the Special Function "Cyclical Control"

- Special safety precautions must be followed for controlling protective devices. For example, it must be impossible to step behind the protective device on the side facing the danger point. Stepping into or through the protected field would automatically cause the dangerous movement to be enabled!
- More specific regulations can be found in the European Standard EN 292-2 in Chapter 4.2.2.5, Control guards.

In addition, the European Standard for Hydraulic Presses EN 693 contains restrictions on the minimum height of the press table and on the maximum dimensions of the access (window) opening. If these stipulations cannot be complied with, additional measures must be taken to reliably monitor the interior of the machine.

2.5 Additional Safety Precautions for the Special Function "Muting"

- Muting is the intended, regulated suppression of the safety function of an AOPD. It is used, for instance, to allow the material flow to pass through the protected field without triggering a signal to shut down the machine.
- During the muting function the protective function of this AOPD is no longer active! For this reason other measures must be taken to ensure that it is not possible to reach or go into the danger zone. For instance, perhaps the material transport completely fills the access area, or perhaps there is no danger while muting is active, such as during the return motion of a tool.

- The muting sensors must be placed so that it is impossible to manipulate them using simple means. For example, optical sensors can be mounted so high or so far apart that the operating personnel cannot cover them either simultaneously or at all. If switches are used, we recommend a concealed installation.
- The operating personnel must be expressly informed that the optical protective device offers no protection in the muting state. Any manipulations of or unauthorized entries into the system present immediate danger to personnel.

- An additional sign should be put up stating that the safety light grid offers no protection when the muting indicator is lit and it is dangerous to reach or walk

through the protected field. Muting indicators, controlled by the MSI, and this sign should be placed in a clearly visible location near the muting area.

3 System Configuration and Functions

3.1 System Configuration

Two microprocessors handle the redundant processing of the signal sequences within the intelligent Modular Safety Interface MSI. The results of the two processors are continuously compared. If any deviations are found, the safety-related outputs are immediately switched off and the LED indicating an MSI failure lights up.

Sensor signals at inputs S1 and S2 are checked. Depending on which of the functions (as described below) are selected, when the protected fields of all connected AOPDs are free the MSI outputs switch automatically to the ON state (without start/restart interlock) or remain in

the OFF state until the reset button has been pressed and released (with start/restart interlock = standard operating mode).

MSI-mi is available with two output options: the MSI-mi/R has two positive-guided normal open contacts, while the MSI-mi/T has two safety-oriented pnp transistor outputs.

The MSI safety interface comes in a 52.5 mm-wide slide-in housing that holds the MSI-mi module, the I/O-m module and the /R or /T output module. It is suitable for mounting on a grounded 35 mm standard rail.

3.2 DIP Switch Settings

3.2.1 DIP Switch Settings for the MSI-mi Module

Cut off the voltage supply to the interface (see safety precautions in Chapter 2.2) loosen the subassembly

with the imprint MSI-mi and pull this module partly out of the housing before resetting the DIP switches:



Functions only in conjunction with external wiring, see Chapter 3.3:

DIP Switch	DS4	DS3	DS2	DS1
Function	None	Locking	External Device Monitoring	Cycle Time-limit
Up		start/restart interlock only	Static*- none**	30 min.
Down		start/restart interlock* - none**	dynamic	30 sec.

Factory setting: all switches down

* See Chapter 3.3.1.1 – 3.3.1.3

** See Chapter 3.3.1.4

• See Chapter 3.3.1.2

•• See Chapter 3.3.1.3 – 3.3.1.5

3.2.2 DIP Switch Settings for the I/O-m Module

Cut off the voltage supply to the interface (see safety precautions in Chapter 2.2) loosen the subassembly I/O-

m to the right of the MSI-mi module and pull it partly out of the housing before resetting the DIP switches:



DIP Switch	MU4	MU3	MU2	MU1
Function	Muting Range 1	Muting Sensors	Muting Time-limit	Muting Function
Up	S1 only	not testable	none	none
Down	S1 & S2	testable	10 min.	muting range 1

Factory setting: all switches down

3.3 Operating Modes and Functions

MSI-mi/R and MSI-mi/T permit the following modes of operation and functions:

- Guard function offers the possibility of combining start/restart interlock and external device monitoring (see below).
- Five operating modes can be selected by means of external wiring and the DIP switches DS2 and DS3 on the MSI-mi module.
- Cyclical operation as single break or double break operation with guard function. In cyclical operation, the AOPD connected at S1 controls the process. Special safety precautions are required as described in Chapter 2, Safety Precautions. Start/restart interlock is

a necessary precondition for cyclical operation. Whenever cyclical operation is selected, terminal 13 must be connected to 24 V DC by way of a reset button! See more in Chapter 3.3.3. A three-point keyed switch is used to select among the operating modes. Changes at this keyed switch may only be made by trained specialists. If just one of the available operating modes is going to be required, we recommend permanently wiring this mode using a bridge.

- Muting function. If testable or non-testable muting sensors are implemented, the protective function of the protective device connected at S1 (or S1 and S2) can be temporarily deactivated in parallel muting mode. Further details are given in Chapter 3.3.4.

3.3.1 Operating Modes Interlocking Functions and External Device Monitoring

The following 5 combinations can be selected by externally wiring the MSI Safety interface and/or by changing

the settings of the DIP switches DS2 and DS3 in the MSI Module:

OPERATING MODES				
Chapter	Type of Locking	Type of External Device Monitoring	Cyclical Function	Muting Function
3.3.1.1	With start/restart interlock	with dynamic ext. device monitoring	possible	possible
3.3.1.2	With start/restart interlock	with static ext. device monitoring	possible	possible
3.3.1.3	With start/restart interlock	without external device monitoring	possible	possible
3.3.1.4	Without start/restart interlock	without external device monitoring	not possible	not possible
3.3.1.5	With start/without restart interlock	without external device monitoring	not possible	not possible



The MSI safety interface is factory-set for the operating mode "with start/restart interlock and dynamic external device monitoring". If this setting is changed, these functions (i.e. the appropriate safety level) must be guaranteed by other means.

- Types of interlocking functions

The „start interlock function“ ensures that when the system is switched on or when the supply voltage returns, even if the protected field is free the safety-related output contacts or transistor outputs (OSSDs) do not automatically go into ON state, but rather wait until the reset button has been pressed and let go. The “ start/restart interlock function“ prevents the OSSDs from automatically entering the ON state when the protected fields of one or more of the connected AOPDs are released again after an interruption. Here as well, the reset button must be pressed and let go to initiate the system. Cyclical operation and muting are not possible if there is no locking (and hence no reset button) since the start button is also used to perform the function of the cyclical and muting reset.

- Types of External Device Monitoring

The function „dynamic external device monitoring“ monitors the relays connected downstream from the MSI safety interface. Each time before the OSSDs switch to the ON state, a check is made of whether the subsequent circuit elements have closed and reopened. If they have not, the OSSDs of the MSI safety interface remain in the OFF state. If the function „static external

device monitoring“ is selected, a check is merely made of whether the subsequent circuit elements are in an open state. If they are, the start/restart interlock can be initiated.

3.3.1.1 Operating Mode: With Start/Restart Interlock – With Dynamic External Device Monitoring

External wiring requirements:

Terminal 13 connected to 24 V DC by way of a start button

Terminal 14 connected to 0 V by way of feedback contacts of the positive-guided downstream relay

Required DIP switch settings in the MSI module (Chapter 3.2):

DS3 down DS2 down (factory setting at delivery)

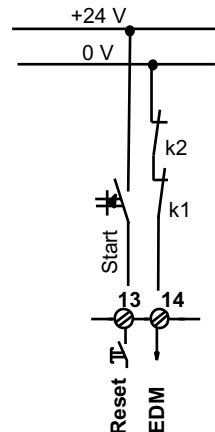

Start/restart interlock is no longer active when the protected fields of all connected AOPDs are free, the downstream relays have returned to their original state, and the reset button is pressed and released.

3.3.1.2 Operating Mode: With Start/Restart Interlock – With Static External Device Monitoring

External wiring requirements:

- Terminal 13 connected to 24 V DC by way of a start button "Reset"
- Terminal 14 connected to 0 V by way of feedback contacts of the positive-guided downstream relay

Required DIP switch settings in the MSI module (Chapter 3.2):

DS3 down DS2 up

In this operating mode, if the protected fields are free, a check is merely made of whether the downstream circuit elements have returned to their original state. If so, a release is issued by pressing and letting go of the reset button.

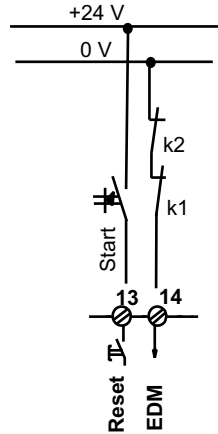

The dynamic monitoring of the downstream relays, which may be required in order to maintain the safety category, must be performed by other means.

3.3.1.3 Operating Mode: With Start/Restart Interlock – Without External Device Monitoring

External wiring requirements:

- Terminal 13 connected to 24 V DC "Reset" by way of a start button
- Terminal 14 connected to 0 V "EDM"

Required DIP switch settings in the MSI module (Chapter 3.2):

DS3 down DS2 up



The dynamic monitoring of the downstream relays, which may be required in order to maintain the safety category, must be performed by other means.

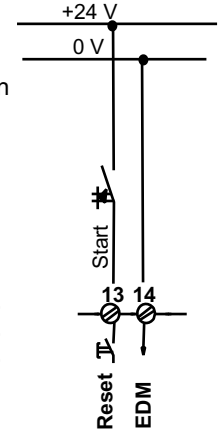

3.3.1.4 Operating Mode: Without Start/Restart Interlock – Without External Device Monitoring

Cyclical and muting operation are not possible in this operating mode!

External wiring requirements:

Terminal 13 connected to 0 V
"Reset"

Terminal 14 connected to
"EDM" 24 V DC

Required DIP switch settings in the MSI module (Chapter 3.2):

DS3 unten DS2 up

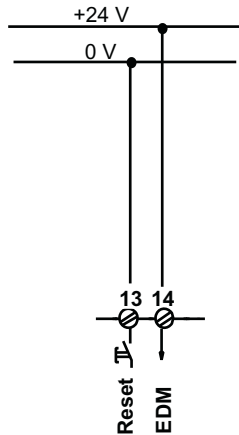

After the supply voltage is applied, the OSSDs immediately go into the ON state if all of the protected fields of the connected AOPDs are free.

In this case, the start/restart interlock function and the dynamic monitoring of the downstream relays, which may be required in order to maintain the safety category, must be performed by other means.

3.3.1.5 Operating Mode: With Start/Without Restart Interlock – Without External Device Monitoring

Cyclical and muting operation are not possible in this operating mode!

External wiring requirements:

Terminal 13 connected to 0 V
"Reset"

Terminal 14 connected to
"EDM" 24 V DC

Required DIP switch settings in the MSI module (Chapter 3.2):

DS3 up DS2 up

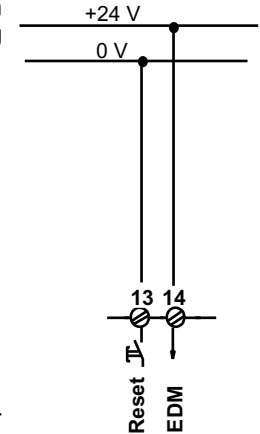

When the protected fields of all connected AOPDs are initially free, the OSSDs first enter the ON state when the protected field of the AOPD connected at S1 (for Type 4: S1 and S2) is interrupted and released. Only then do the rest of the connected AOPDs respond to the interruption and release of their own protected fields by switching the OSSDs directly to the OFF and ON states.

In this case, the restart interlock function and the dynamic monitoring of the downstream circuit elements, which

may be required in order to maintain the safety category, must be performed by other means.

3.3.2 Guard Operation, Test Function

If the protected fields are free, it is possible to simulate an interruption of the protected field of the AOPD connected at S1 (for Type 4: S1 and S2) by way of the "Clear" input. During this procedure, the safety-related outputs will switch to the OFF state. Test is activated if 24 V DC at Pin 20 is disconnected via a normal closed contact.

3.3.3 Cyclical Operation as Single Break or Double Break with Guard Function

Special safety precautions must be taken when the protective device is used to control the machine. These are described in Safety Precautions, Chapter 2.4.

At terminal 21 "Select" you can choose the operating modes "guard only", "single break operation" or "double break operation". Start/restart interlock is a necessary precondition for cyclical operation, which means that terminal 13 must always be connected to 24 V DC by way of the start button. There are some options available with regard to external device monitoring. It can be performed either dynamically or statically, or it can be dispensed with completely if the requirements for maintaining the safety category are fulfilled by other means.

Cyclical Operation:

The start interlock ensures that the OSSDs remain in the OFF state after the supply voltage has been switched on. The display "start/restart interlock" (symbol: lock) is constantly lit.

If operating mode "Start Interlock only" (as in Chapter 3.3.1.5) is selected, the "Clear" input also serves as the remote start for the AOPD connected at S1 (for Type 4: at S1 and S2). In this case, it is no longer necessary to initiate the first start by interruption the protected field.

The following applies for single break operation:

When the start button is pressed, the readiness for cyclical operation is achieved, and the display "start/restart interlock" emits a single blink which is repeated in short intervals. The controls remain in this condition and wait for a controlling interruption of the protected field for at least 300 ms.

The following applies for double break operation:

When the start button is pressed, the readiness for cyclical operation is achieved, and the display "start/restart interlock" emits a double blink which is repeated in short intervals. After the first interruption for at least 300 ms, the display emits a repeated single blink. The controls remain in this condition and wait for the second controlling interruption of the protected field.

Cycling Operation Time monitoring

A time monitoring function prevents other controlling interruptions of the protected field after a period of 30 s following the "readiness" or the last controlling interruption of the protected field. After this 30-second period the

start/restart interlocking function is automatically actuated, and the yellow LED lights constantly. By a press of the reset button, the "readiness" for further controlling interruptions may be restored.

This function safeguards against the unintentional and unexpected initiation of a processing cycle after a longer standstill. In justified cases only, and if this does not create any additional danger to the operating personnel, the time monitoring function can be switched to 30 min. by the way of the DIP switch DS1. See Chapter 3.2.1.

3.3.4 Muting Function

Muting is the intended, regulated suppression of the protective function. Special safety precautions must be observed if muting is being used (see Chapter 2.5). Parallel muting is possible when the DIP switch MU1 in the I/O-m module remains in its original setting (down) and the muting sensors M2 and M3 and the muting indicators are connected. Special note for muting Type 2 AOPDs

When the DIP switch in the I/O-m module is factory-set (MU4 down), the muting function applies for safety inputs S1 and S2. If a Type 2 AOPD is going to be muted, the muting range 1 must be reset to "S1 only" (MU4 up). In addition, the Type 2 AOPD to be muted must be connected at S1. For the setting, see Chapter 3.2.2.

Combination of Cyclical and Muting Operation

When properly installed, MSI-mi provides protection during the entire processing stroke. Sometimes, however, it is important for reasons of safety or operating sequence not to interrupt the production process during certain phases, such as when a stamp perforates the material. In this case, the muting function can be used to deactivate the protective function for the duration of the non-dangerous part of the processing movement. Muting could, for instance, take effect when the stamp has come to within 6 mm of the material and there is no danger posed by other machine parts during the perforation and return motion of the tool. An example is given in Chapter 3.3.4.6.

3.3.4.1 Parallel Muting (0.5 s), Connections M2 and M3

The muting process is initiated if the two inputs switch simultaneously (within 0.5 s of each other). Parallel muting is used in order to suppress the protective function of an AOPD during the non-dangerous part of a cyclical movement.

3.3.4.2 Testable and Non-Testable Muting Sensors

The following devices are suitable for use as muting sensors:

- non-testable light barriers (through-beam operation or retro-reflective barriers with pnp output, dark-switching)

- testable and non-testable reflective light scanners (pnp output, light-switching)
- mechanical limit switches
- inductive proximity switches
- induction loops if metallic objects are being conveyed into the path to be muted.



The cables to the individual muting sensors must be laid separately

Non-Testable Muting Sensors

Requirement: DIP switch MU3 in the I/O-m module must be up

- pnp or switch output must provide 0 V in the non-damped state
- pnp or switch output must provide 24 V DC in the damped state

Example: LSSR3.8-S8 and LSER3/44-S8, polarized for dark-switching, from Leuze electronic

Testable Muting Sensors

Requirement: DIP switch MU3 in the I/O-m module must be down (factory setting)

- Reflective light scanners, light-switching, are suitable. Activating/test input required, Response time: 2 to 18 ms
- test signal T1 must be used for the muting sensor at M2

- test signal T2 must be used for the muting sensor at M3
- pnp output must provide 0 V in the non-damped state and +24 V (plus above-mentioned test impulses) in the damped state

Example: PRK46B/66-S12, polarized for light-switching, from Leuze electronic

3.3.4.3 Muting Display Function

Single muting for S1/S2, or in the case of type 2 for S1 only

In case of muting, terminal 28 will deliver + 24 V DC to the muting indicator 1 connected to it to indicate the muting.

Terminal 29 serves as backup for the case that muting indicator 1, which is connected to terminal 28, should fail (broken filament or interrupted supply). To ensure trouble-free operation, also in the case of malfunction of muting indicator 1 connected to terminal 28, a muting indicator 2 must be connected to terminal 29 to serve as back-up unit to take over the indicating function in case of failure.

With the automatic switching over from muting indicator 1 to muting indicator 2, the assigned LED "lamp warn " on the I/O mx module will flash up (1 pulse). If muting indicator 2 should fail (it is monitored constantly, even if it is not switched on), the LED "lamp warn " will also flash up (2 pulse).

In addition to the indication, these pulses (1 pulse or 2 pulses) are also directed to output terminal 30. This

output will deliver an active - high signal during trouble-free operation. However, if the second indicator also fails, the MSI-mi will enter a state of malfunction and the OSSDs will switch to the OFF state.

3.3.4.4 Start while muting sensors are activated

If muting sensors are activated when the power is switched on (after mains failure, emergency stops or muting sequence failure) starting is possible under the following condition:

If the sensing field of the AOPD to be muted is free (and all other conditions are reached) pressing and releasing the reset button sets the machine in motion. Muting is not activated.

Muting is activated only, when the muting sensors are firstly deactivated and after that newly and simultaneous activated again within 0.5 s.

If the sensing field of the AOPD to be muted is interrupted, e.g. by a swivelling device, starting with the reset button is not possible. In this case it is recommended to either remove the swivelling device or move by step motion into a position, where the sensing field is free.

3.3.4.5 10-Minute Muting Time-Limit

Regardless of the selected muting mode, the MSI safety interface reports a muting malfunction when the duration of a muting state exceeds 10 minutes.

The muting time-limit is obligatory. While it is possible to switch off the muting time-limit at the DIP switch MU2 in the I/O-m module, this is only allowed in justified cases, such as when the flow of material into the muting path is normally uninterrupted.

3.3.4.6 Example: Combination of Cycling and Muting Operation

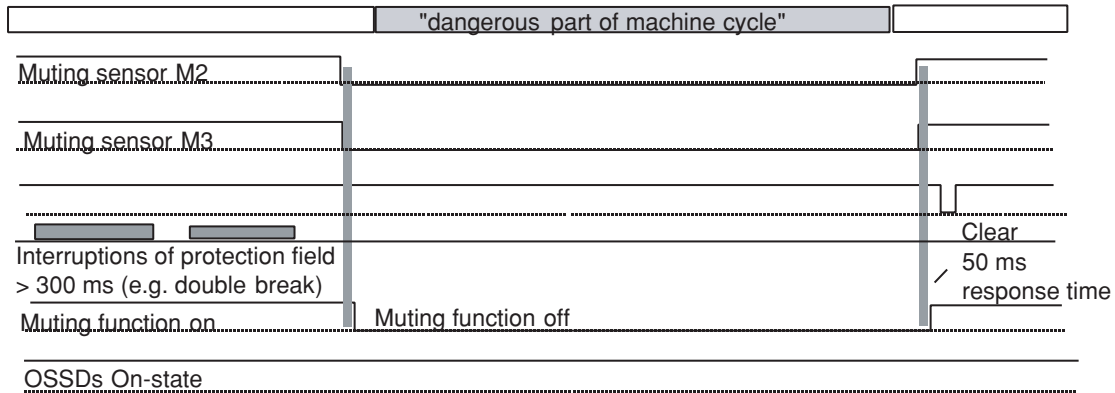
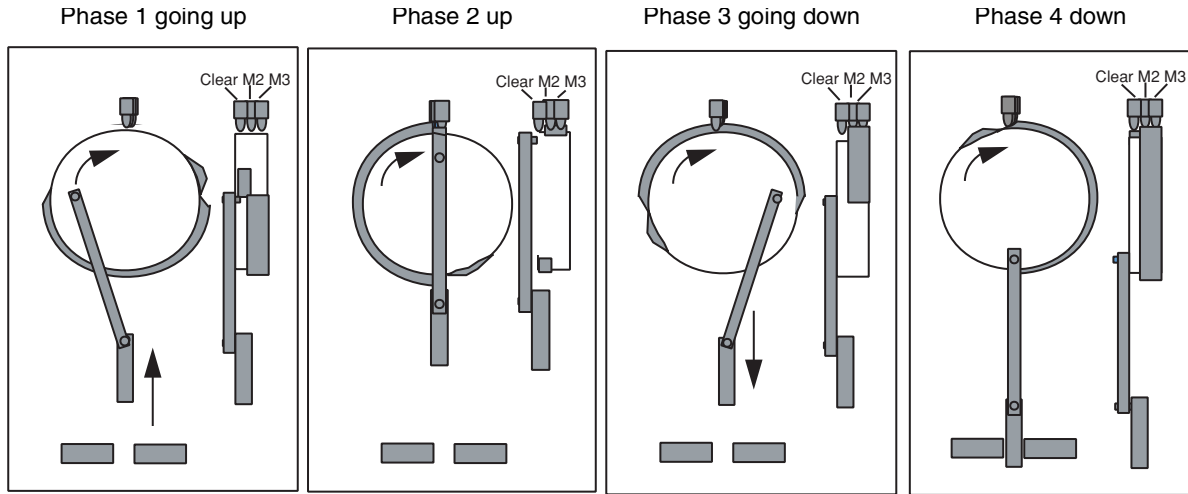

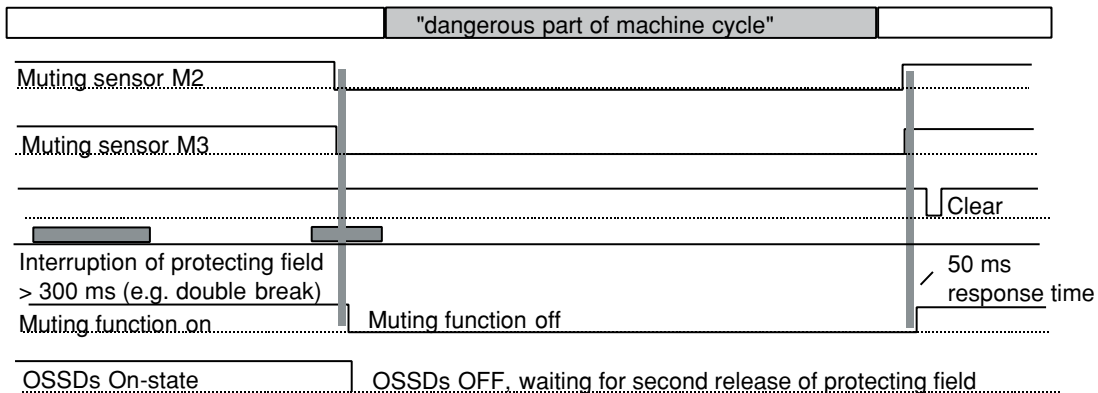
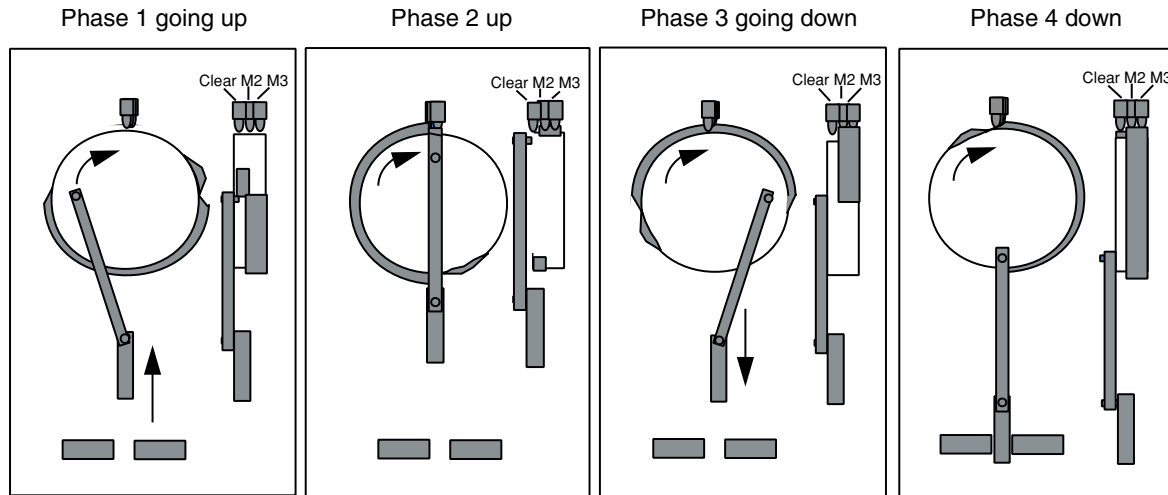

3.4 Displays

A number of LEDs of various colors indicate the operating status of the MSI modular safety interface. It is also possible to show the LED displays on the PC monitor

using the integrated RS 232 interface and diagnosis connector.

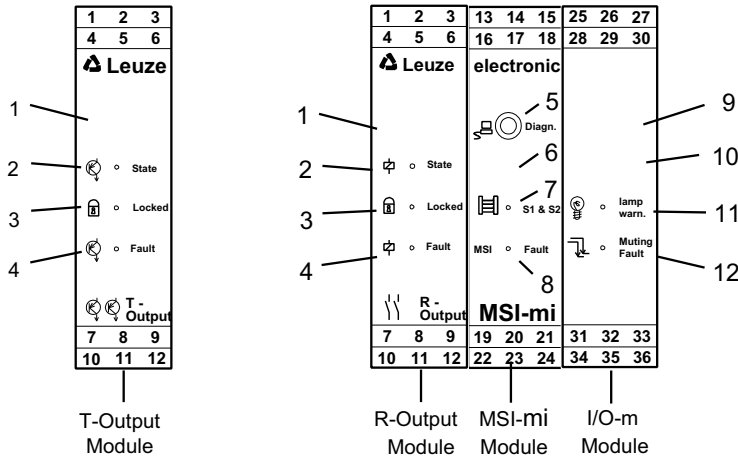

Output /R /T					
Position	Display/Function	Symbol	Status	LED	Color
1	not applicable	–	–	–	–
2	Safety-related switch output	relay/trans. State	ON OFF	on on	green red
3	Start-/restart interlock – Wait for 2 cycles – Wait for 1 cycle	lock	locked locked locked not locked	on blinks 2 x blinks 1 x off	yellow yellow yellow
4	Fault in output module	relay/trans. Fault	fault no fault	on off	red

MSI-mi Module					
Position	Display/Function	Symbol	Status	LED	Color
5	Diagnosis, RS 232 See status outputs	jack diagn.	none	none	none
6	not applicable	–	–	–	–
7	Protected field	AOPDs S1 & S2	protected field free not free	on off	green
8	MSI fault	MSI fault	fault no fault	on off	red

I/O-m Module					
Position	Display/Function	Symbol	Status	LED	Color
9	not applicable	–	–	–	–
10	not applicable	–	–	–	–
11	Muting indicator	broken filament short circuit interruption	defect indicator 1 defect indicator 2 no defect	blinks 1 x blinks 2 x off	red red
12	Muting failure	sequence error	failure no failure	on off	red

3.5 Status Outputs



Status outputs are not allowed to be used as safety-related signals in release circuits

(see also Chapter 2.2. Operating Conditions and Proper Use).

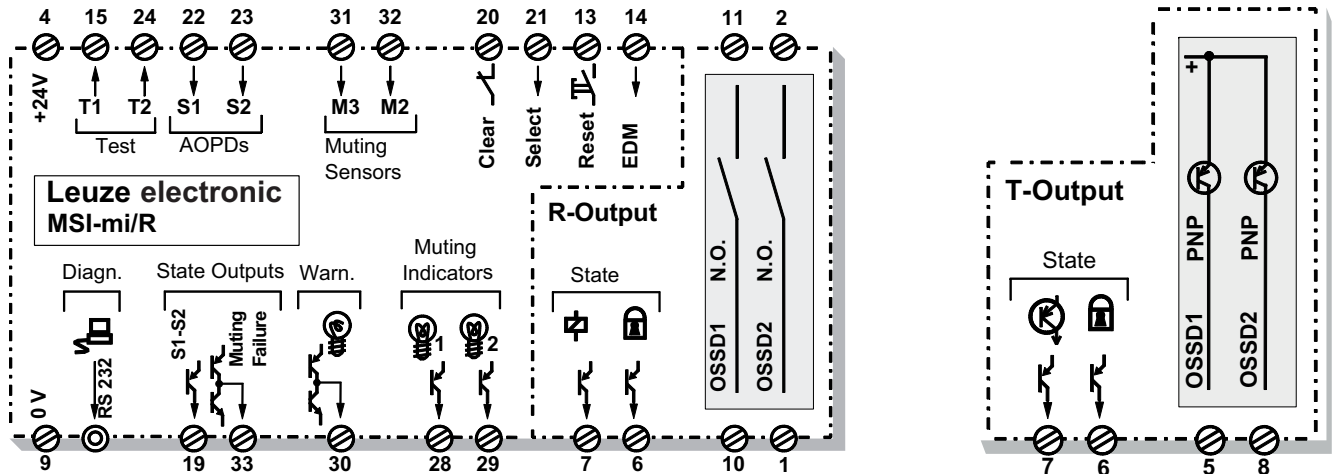

Output /R /T				
Terminal	Message Function	Symbol	Status	Status Output
6	Start/restart interlock – Wait for 2 cycles – Wait for 1 cycle	lock	locked locked locked not locked	active high impulse 2 x impulse 1 x active low
7	Safety-related switch status	relay/ transistor	ON OFF	active high active low

MSI-mi Module				
Terminal	Message Function	Symbol	Status	Status Output
Front jack	Diagnosis, RS 232 2.5 mm round connector	–	–	connected to PC with diagnosis program
19	Protected field(s)	S1 - S2	free not (all) free	active high active low

I/O-m Module				
Terminal	Message Function	Symbol	Status	Status Output
28	Muting indicator 24 V, 5 W max.	Lamp	muting on muting off	active high active low
29	Muting indicator 24 V, 5 W max.	Lamp	muting on muting off	active high active low
30	Warning Muting indicator defective	broken filament short circuit interruption	indicator OK defect indicator 1 defect indicator 2	active high impulse 1x impulse 2x
33	Muting failure	Muting Failure	no failure muting failure	active high active low

3.6 Diagnosis Function

Requirements for running the diagnosis system: a standard PC or laptop operating under Windows (Version 3.1 or higher) and the MSI software, Version 01, on 3 1/2 " diskette, as well as a serial connection cable and a 2.5 mm jack plug.

- Simultaneous display of all input and output statuses as well as all LED displays on the MSI

With its diagnosis interface, the intelligent modular safety interface MSI offers a convenient way to visualize all of the input and output statuses simultaneously on the monitor.

The connection circuit diagram as well as display fields in different colors can be shown on the screen via the connection terminals. A graphic representation of the MSI front design with the display elements as described in Chapter 3.4 also appears on the screen.

Example:

Diagnose-Programm MSI

Prog. version: 0.00

restart-interlock:	without
EDM - mode:	dynamic
EDM:	without
relay prewarning:	100k
relay zyklen:	0k
start test emulation:	no
time monitoring:	without
muting sensor test:	without
muting timeout:	without
muting mode:	Leuze

S1: n.c.
 S2: n.c.
 S3: n.c.
 S4: n.c.
 ME1: n.c. SS1a: n.c.
 ME2: n.c. SS1b: n.c.
 ME3: n.c. SS2a: n.c.
 ME4: n.c. SS2b: n.c.

COM1 Klemmen- und LED-Farben: rot = 0V, grün = 24V, gelb = hochohmig

Start Pronto E-Mail Diagnose-Programm... 09:49

This enables the sequences at individual screw-type terminals to be tracked without the use of additional measuring instruments. The diagnosis function is equip-

ped with on-line help and can be operated in either English or German.

4 Electrical Connection

4.1 Installation Regulations



The general safety precautions in Chapter 2 must be observed. The electrical installation may be performed only if there is no voltage applied, and it must be performed by trained specialists.



In the /R versions, it is possible that high voltages may be present at the output contacts. A no-voltage state is achieved only when the 24 V DC supply voltage as well as the supply lines to the switch contacts are safely

4.2 Power Supply Requirements



The supply voltage of 24 V DC must guarantee safe mains separation and be able to bridge an interruption in voltage of 20 ms at full load. The MSI-AC 115 or MSI-AC 230 from Leuze electronic have these capabilities up to 0.8 Amps. The ground connection of the MSI is made

4.3 Connecting AOPDs, Type 4 or Type 2

The examples below show possibilities for connecting and combining AOPDs of various safety categories and with various output features (relays, safety-oriented transistor outputs, cross circuit monitoring within and outside the AOPD).

AOPDs Type 4 with transistor outputs and cross connection monitoring function can directly be connected to the safety inputs S1 and S2. See Example 1.

switched off and secured against being switched on again.



Coded plug-in terminal blocks allow a connection cross-section of up to 2.5 mm². The supply voltage must be externally fused against excess current with a fuse of 2.5 A. The switch contacts must also be externally fused against excess current with a maximum of 5 A. This prevents the safety-related contacts from welding together if the current load is too high!

when it snaps up to the metallic, grounded mounting rail by means of the rear clamping device.

The lead for the supply voltage must be externally fused against excess current with a maximum of 2.5 A.

AOPDs Type 4 with relay outputs must be connected so that the odd-numbered test signal T1 are directed via the non-delaying contacts to an odd-numbered safety input (T1=>S1) and vice versa (T2=>S2). See Example 2.

AOPDs Type 2 are periodically tested using the time-displaced test signals T1 or T2. The odd-numbered test signal must be directed to an even-numbered safety input by the way of the time-delaying AOPD (T1=>S2) and vice versa (T2=>S1). The AOPD response time to a

test request must be in a range of 2 to 18 ms. See Example 3.

All available safety inputs must be occupied! In case no components are connected, the remaining inputs

must be connected to the corresponding test signal using bridges. In doing so, please note that the odd-numbered test signal must be connected to the odd-numbered safety input via the non-delaying bridge (T1 => S1) and vice versa (T2 => S2). See Example 4.

Example 1

1 AOPD Type 4 with 2 safety-related transistor outputs and internal cross connection monitoring function.

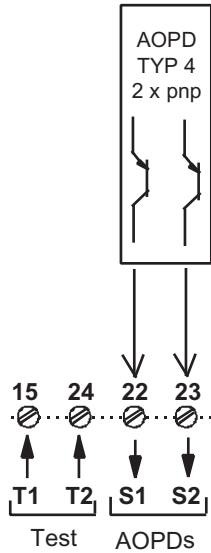

Example 2

1 AOPD Type 4 with 2 normally open relay contacts. Cross connection monitoring by using the test signals T1 and T2.

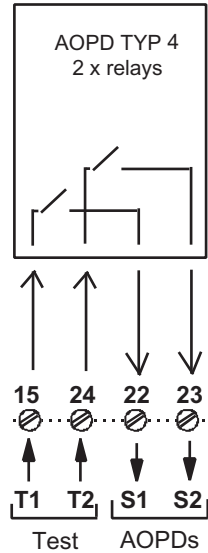

Example 3

2 AOPDs Type 2 with one safety-related transistor output each. Cross connection monitoring between the leads will be detected.

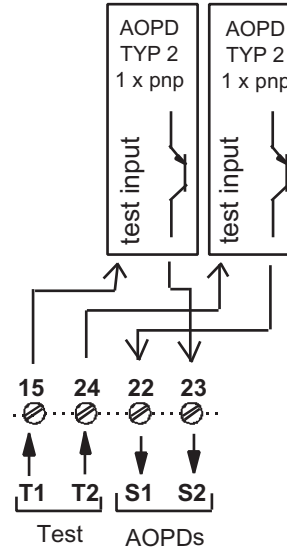

Example 4

1 AOPD Type 2 with one safety-related transistor output.

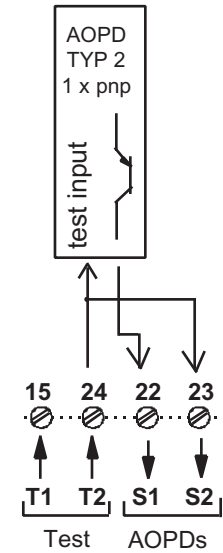

4.4 Connecting Machine Controls



The safety-related parts of the controls comprise more than the MSI-mi/R or MSI-mi/T described above. They also include successive control elements and even power transmission elements which must be safely and promptly shut down. Particular attention must be paid to maintaining the safety category requirements. Important information in this regard can be found in the harmonized European standard EN 954-1.



Essential prerequisites for safe operation are the abilities to electrically influence the interruption of the dangerous movement and to bring the machine to a standstill as quickly as possible. These factors, as well as the response times of AOPDs and the MSI, must be taken into consideration when calculating the safety distance.

The response times depend on the type of AOPD selected (see Chapter 6, Technical Data). Other parameters, such as hand/arm/body approach speed or additional safety distance, depend on the particular application and the resolution of the AOPD being used. The European standard EN 999 contains equations and examples for a variety of configurations.

Before starting the next cycle the MSI Safety Interface demands the automatic feedback of the machine cycle. The normal closed contact between 24 V DC and terminal 20 (Clear) must be interrupted for a minimum duration according to the Technical Data below. This causes all fed-in cycles to be cleared. The output contacts enter the OFF state when the cycle clearance procedure is performed.

5 Connection Circuit Diagram, Examples

The connection examples below show one wiring suggestion each for the MSI-mi/R and the MSI-mi/T

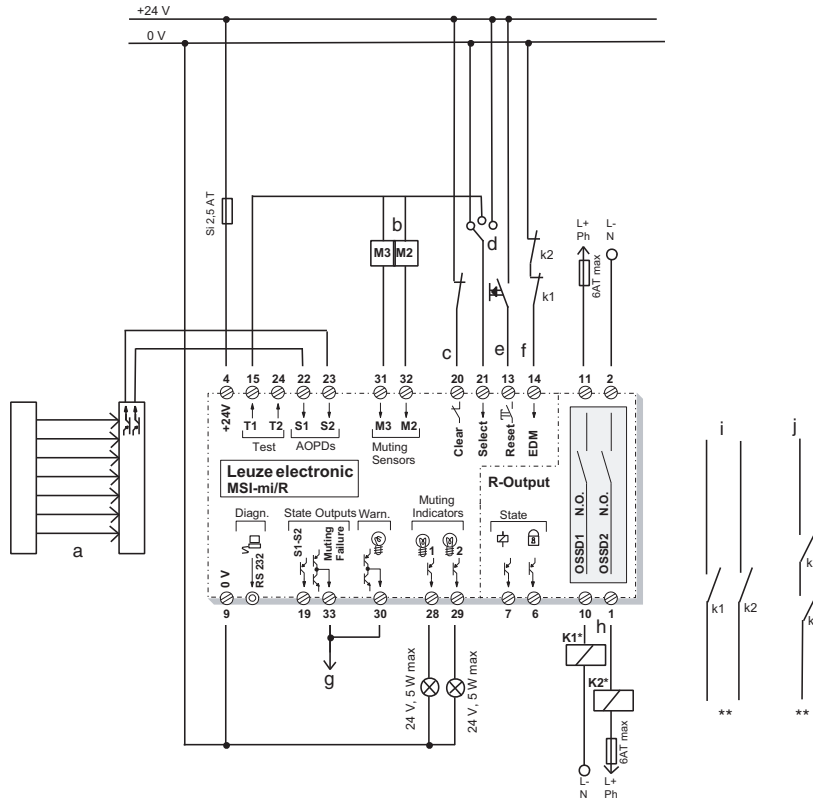

Connection example MSI-mi/R with one AOPD Type 4

- a = AOPD Type 4 with guarding, control and muting function
- b = M2, M3, Non-testable muting sensors (e.g. mechanical switches), parallel muting mode
- c = Normally closed machine contact for cycle clearance
- d = Operating mode keyed switch (guard only = 0 V, single-break = T1, double-break = 24 V)
- e = Command device for releasing the start/restart interlock
- f = Feedback loop for external device monitoring
- g = Possible collective output for warning/error indications
- Pin 19 = Indicating output "sensor status"
- Pin 33 = Indicating output "muting failure"
- Pin 30 = Warning output "Muting indicator defective"
- Pin 28/29 = Output Muting indicators 1 and 2
- Pin 7 = Indicating output "status safety outputs"
- Pin 6 = Indicating output "status start/restart interlock"
- h = Output Signal Switching Devices (OSSDs)
- i = Switching off path with two-channel control
- j = Switching off path with one-channel control
- * = Suitable spark suppression required
- ** = In general, both of the contacts must be used in the subsequent machine control path.
Use relays or contactors with positive-driven contacts only.

All available safety inputs must be occupied!

See Chapter 4.3.

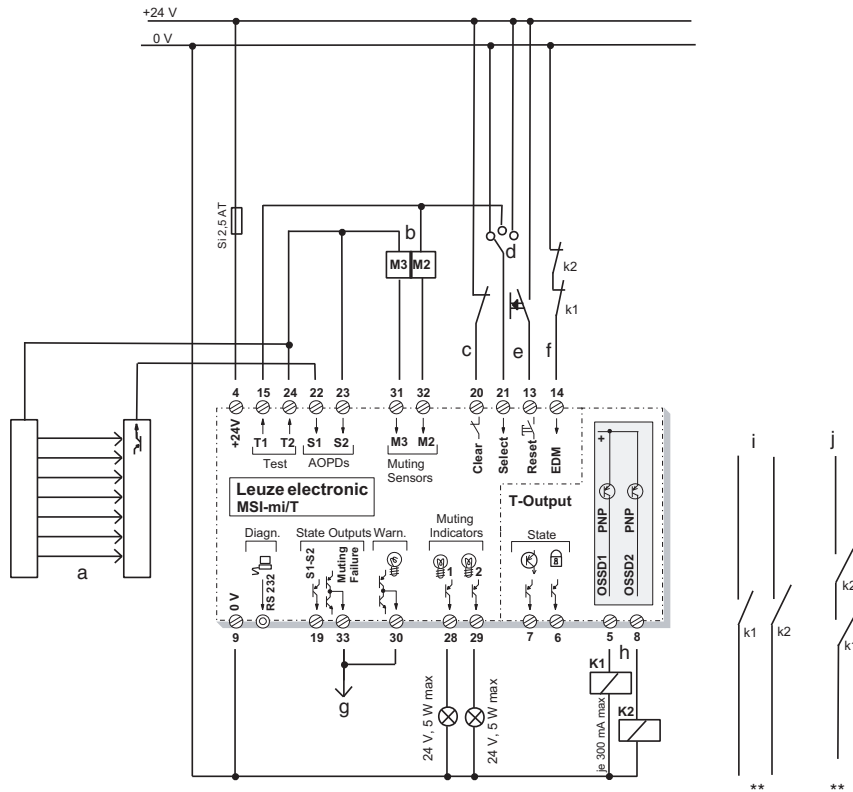

Connection example MSI-mi/T with one AOPD Type 2

- a = AOPD Type 2 with guarding, control and muting function
- b = M2, M3, Testable muting sensors (e.g. mechanical switches), parallel muting mode
- c = Normally closed machine contact for cycle clearance
- d = Operating mode keyed switch (guard only = 0 V, single-break = T1, double-break = 24 V)
- e = Command device for releasing the start/restart interlock
- f = Feedback loop for external device monitoring
- g = Possible collective output for warning/error indications (active low)
- Pin 19 = Indicating output "sensor status"
- Pin 33 = Indicating output "muting failure"
- Pin 30 = Warning output "Muting indicator defective"
- Pin 28/29 = Output Muting indicators 1 and 2
- Pin7 = Indicating output "status safety outputs"
- Pin 6 = Indicating output "status start/restart interlock"
- h = Output Signal Switching Devices (OSSDs)
- i = Switching off path with two-channel control
- j = Switching off path with one-channel control
- ** = In general, both of the contacts must be used in the subsequent machine control path.
Use relays or contactors with positive-driven contacts only.

All available safety inputs must be occupied!

See Chapter 4.3.

6 Technical Data and Ordering Information

6.1 MSI-mi/R, MSI-mi/T

Version, Type Modular Safety Interface	MSI-mi
Relevant standards, Safety category	TYPE 4 in accordance with EN IEC 61496 T1 see also Chapter 2, Safety Precautions EN 954-1 (12/96). Category 4 IEC, DIN EN 60204-1 (11/98), Stop 0 DIN V VDE 0801 and A1, Specification Class 6
Connectable safety sensors S1-S2	1 AOPD, Type 4, Type 3 or up to 2 AOPDs, Type 2 (all in accordance with EN IEC 61496)
Test outputs T1 and T2, Test interval Test impulses, time-displaced Response time AOPD Type 2 to a test request	200 ms 24 ms each 2 to 18 ms
Available functions	Start/restart interlock External device monitoring Guard only, single break and double break operation Parallel muting (0.5 s)
Minimum sensing field interruption for cycling control	300 ms
Control input Start/restart interlock (Reset)	Potential-free normal open contact (button or key button)
Control input External device monitoring (EDM)	Feedback of positive-guided contacts from downstream relays (see connection diagram)
Control input Operating mode (Select)	Operating mode keyed switch or bridge for permanent operating mode

Protective class	II
Ambient temperature, Operation	0 ... + 55 °C.
Ambient temperature, Storage	-25 ... + 70 °C
Relative humidity	93 % max.
Connection type	pluggable, coded screw-type terminals up to 2.5 mm ²
Dimensions	See dimensional drawing

6.2 /R-Output

OSSD safety outputs switching voltage/switching current	2 safety-related normal open contacts 60 V DC, 250 V AC, 5 A max. Minimum switching current 20 mA
OSSD external fusing	5 A m
OSSD response time MSI (without AOPD)	for AOPD Type 4, transistor outputs 22 ms for AOPD Type 4, relay outputs 64 ms for AOPD Type 2 64 ms for safety switches (electro-mechanical) 64 ms
OSSD reset time	100 ms
OSSD suitable spark extinguishing over the coils of the downstream relays	Required
 Status output "Status switch outputs" not to be used for safety circuit!	pnp switch output OSSDs ON-state: active high, 24 V DC, 60 mA max. OSSDs OFF-state: active low
Status output "Status start/restart interlock"	pnp switch output locked: active high, 24 V DC, 60 mA max. not locked: active low

6.3 /T-Output

OSSD safety outputs switching voltage/switching current	2 safety-related pnp transistor outputs with cross connection monitoring 24 V DC, 300 mA max.								
OSSD response time MSI (without AOPD)	<table> <tr> <td>for AOPD Type 4, transistor output</td> <td>12 ms</td> </tr> <tr> <td>for AOPD Type 4, relay output</td> <td>54 ms</td> </tr> <tr> <td>for AOPD Type 2</td> <td>54 ms</td> </tr> <tr> <td>for safety switches (electro-mechanical)</td> <td>54 ms</td> </tr> </table>	for AOPD Type 4, transistor output	12 ms	for AOPD Type 4, relay output	54 ms	for AOPD Type 2	54 ms	for safety switches (electro-mechanical)	54 ms
for AOPD Type 4, transistor output	12 ms								
for AOPD Type 4, relay output	54 ms								
for AOPD Type 2	54 ms								
for safety switches (electro-mechanical)	54 ms								
OSSD reset time	100 ms								
 Status output "Status switch outputs" not to be used for safety circuit!	pnp transistor output OSSDs ON-state: active high, +24 V, 60 mA max. OSSDs OFF-state: active low								
Status output "Status start/restart interlock"	pnp transistor output locked: active high, + 24 V, 60 mA max. not locked: active low								

6.4 Dimensional Drawing

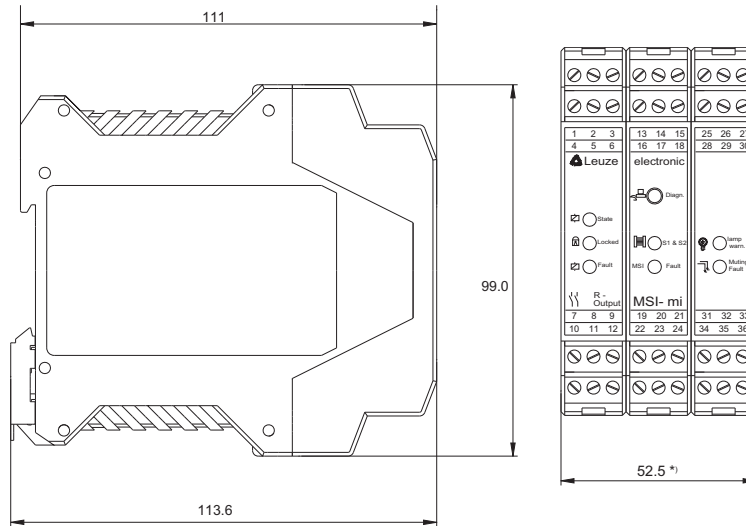

*) Stringing together without distance possible

6.5 Ordering Information

Type	Part No.
MSI-mi/R	549906
MSI-mi/T	549926
MSI-AC 115 (power supply 24 V DC, 0.8 A)	549940
MSI-AC 230 (power supply 24 V DC, 0.8 A)	549908

MSI diagnosis software	549930
diagnosis cable 3 m	549953
diagnosis cable 5 m	549955
/R output subassembly (replacement part)	509210
/T output subassembly (replacement part)	509202

7 Declaration of Conformity

Leuze electronic GmbH + Co. KG
In der Braike 1
73277 Owen - Teck / Germany

The manufacturer declares that the safety components of series **MSI-mi** in the form in which they are marketed by us conform with the relevant, basic safety and health requirements of the EC directives*, and that the standards* were used in their design and construction.

Owen, 01.02.2009



Dr. Harald Grübel
General Manager

* You can also download this EC Declaration of Conformity from the Internet under:
<http://www.leuze.com/msi-m>