

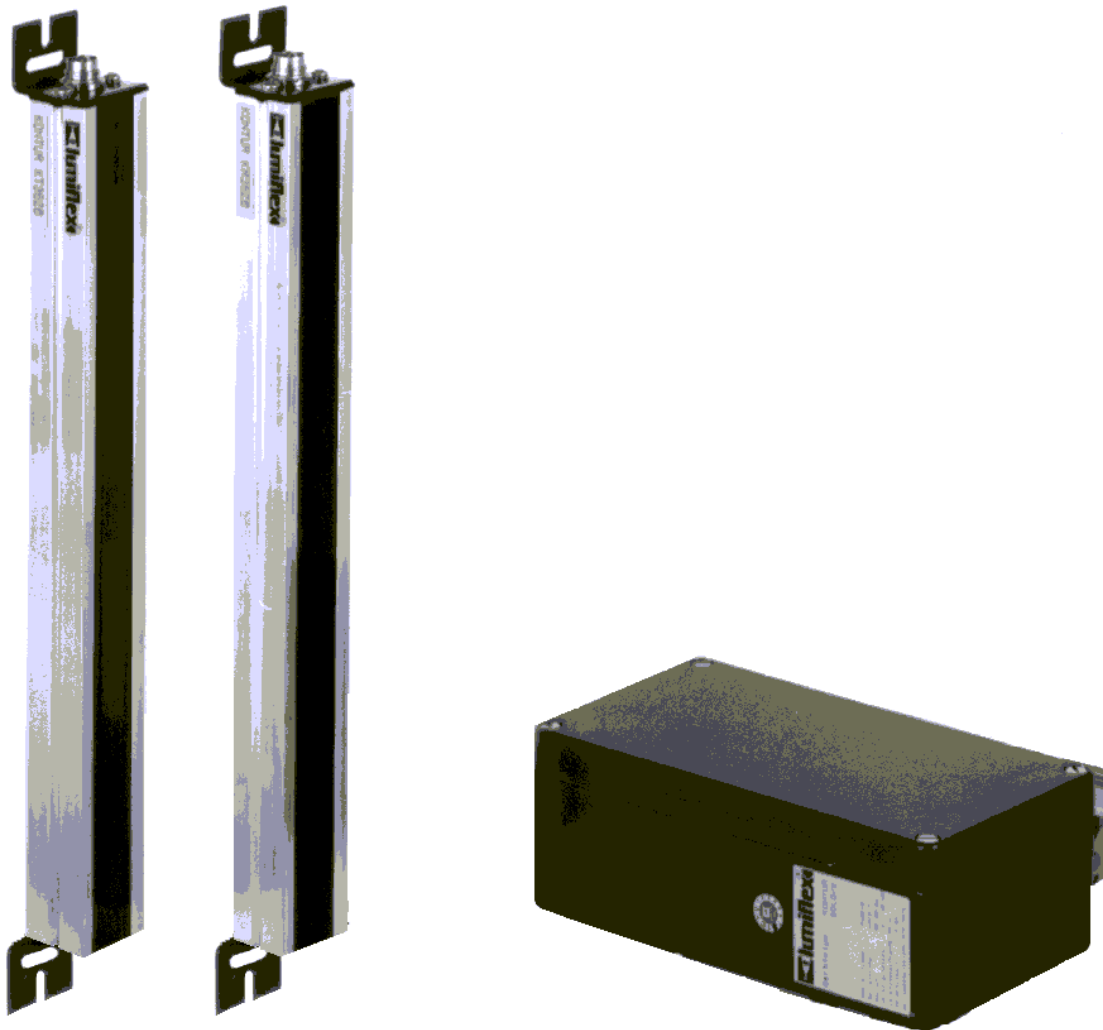

KONTUR

Measuring Light Curtain

Connecting and Operating Instruction Manual



600940 – 02/06 Subject to change without prior notice

About This Connecting and Operating Instruction

These operating instructions contain information regarding the proper and effective use of KONTURlight curtains. It is included in the scope of delivery.

Safety precautions and warnings are designated by the symbol .

Leuze lumiflex GmbH + Co. KG is not liable for damage resulting from improper use of its equipment. Familiarity with these instructions constitutes part of the knowledge required for proper use.

© This manual may not be reprinted or copied, in full or in part, without the express permission of:

Leuze lumiflex GmbH + Co. KG
Liebigstraße 4
D-82256 Fürstfeldbruck, Germany
Tel. +49 8141 5350-0
Fax +49 8141 5350-190
E-Mail: lumiflex@leuze.de
www.leuze.com

TABLE OF CONTENTS

1	Description of Unit	5
1.1	Introduction	5
1.2	Features of KONTUR Measuring Light Curtain	6
1.3	Types and Designation.....	6
1.4	Interface to the Machine Control System.....	7
1.5	Instructions for Appropriate Use.....	7
2	Design and Functions.....	8
2.1	Measuring Principle.....	8
2.2	Measured Values and Data Preprocessing	8
2.2.1	Single Beam Information.....	8
2.2.2	Data Preprocessing.....	9
2.3	Automated or Controlled Scanning?.....	10
2.3.1	Automated Scanning (Option I)	11
2.3.2	Controlled Scanning (Option II)	12
2.4	KONTUR Control Units	12
2.5	Configuration of Measured Value Output	13
2.5.1	Programmable Parameters and their Meanings	13
2.5.2	Table of Beam Numbers in Hexadecimal Notation	15
2.5.3	Identification Number of Output Values.....	17
2.5.4	The Programmable Part of the Program Register	18
2.6	Time Needed for a Complete Measuring Cycle.....	21
2.6.1	Time Needed for Automated Scanning	22
2.6.2	Time Needed for Controlled Scanning	22
3	Application Examples for Automated Scanning	23
3.1	Principle Criteria of Use.....	23
3.2	Application Examples	24
4	Application Examples for Controlled Scanning.....	25
4.1	Principle Criteria of Use.....	25
4.2	Application Examples	25

5	Fitting.....	26
6	Electrical Connection	27
6.1	Connection Light Curtains - Control Unit	27
6.2	Connection to the Machine Control System.....	27
7	Start-Up.....	29
7.1	Display Elements	29
7.2	Checks before Initial Operation	30
7.3	Alignment of Transmitter and Receiver	30
8	Troubleshooting and Fault Rectification.....	31
9	Cleaning the Protecting Screens	33
10	After Sales Service.....	33
11	Appendix.....	34
11.1	Technical Data KONTUR Light Curtains	34
11.2	Dimensional Drawing KONTUR Light Curtains.....	34
11.3	Dimension Table KONTUR Light Curtains	36
11.4	Technical Data KONTUR Control Units.....	37
11.5	Dimensional Drawing KONTUR-TRIO and KONTUR-SOLO/p Control Units	38
11.6	Dimensional Drawing KONTUR-SOLO/p Control Unit.....	38
12	Order Details and Scope of Supply.....	39
13	EC Declaration of Conformity	40

1 Description of Unit

1.1 Introduction

Continuous optimization of production processes demands for constantly faster and more precise sensors. With the measuring light curtain KONTUR a robust industrial measuring system is now available to the user. Lengths, widths, heights, but also contour or position may be determined depending on the arrangement of the sensors. The processed data can be transmitted to a subsequent machine control system. At only one control unit KONTUR-TRIO up to three measuring light curtains may be connected in order to determine e.g. length, width and height simultaneously (Figure 1-1).

Fig. 1-1 KONTUR consists of an light curtain (transmitter, receiver) and a control unit. Up to three light curtains can be connected to a KONTUR-TRIO control unit.

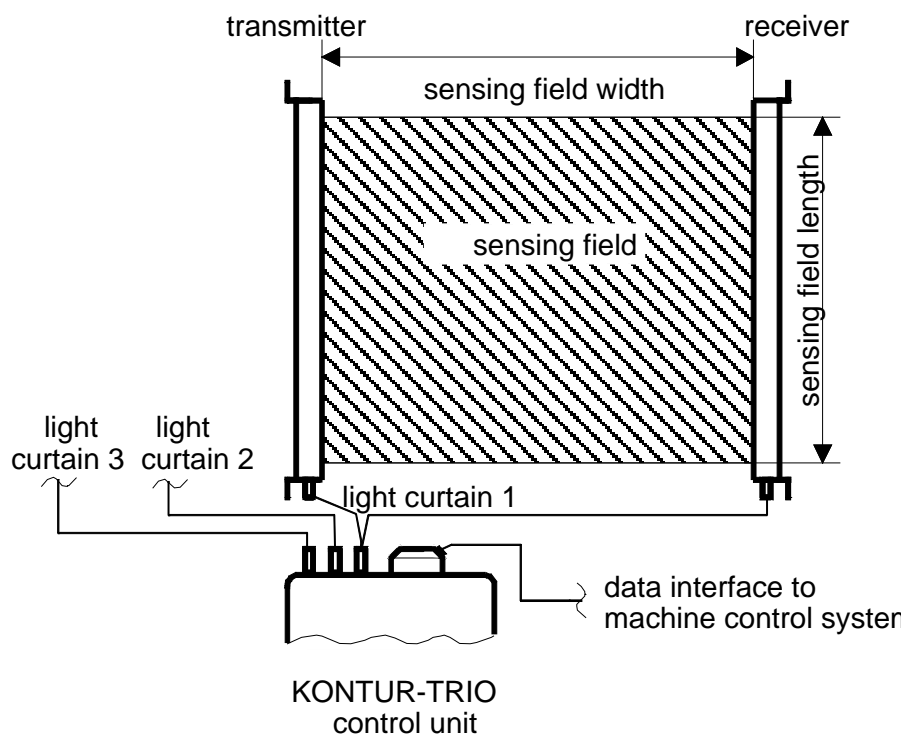

The KONTUR measuring light curtain consists of transmitter, receiver and control unit. An array of infrared

light beams form the sensing field. If an object enters into the sensing field a certain number of light beams will be interrupted according to its size. The microcontroller of the KONTUR control unit provides control functions for transmitter and receiver and evaluates the result of the measurement. According to its program configuration either the status of individual light beams or preprocessed data are delivered to the subsequent machine control system. Via parameters the user can determine which kind of output is provided. Thus, the software allows for adaption upon various applications.

Lumiflex engineers will assist you in case of adaption and programming of parameters.

1.2 Features of KONTUR Measuring Light Curtain

- Electro-sensitive measuring system
- Up to three light curtains may be connected to one control unit
- Results of measurement independent of the surface properties of the object
- Easily adaptable software for various applications via programmable parameters.
- Space-saving slim optical units
- High scanning rate for immediate result of measurement

1.3 Types and Designation

The optical parts of KONTUR are available with three different beam distances: 10 mm, 20 mm and 40 mm. For this reason a minimum resolution of 15 mm, 25 mm and 45 mm results for the measuring light curtain (worst case view, when the object is located exactly between two associated light beams). These resolutions are determined by the geometry of the measuring system and can be guaranteed for each position within the sensing field. These three types are available for sensing field lengths from 120 mm up to 3000 mm. The maximum distance between transmitter and receivers (the sensing field), is the same for all types and is 3.5 m.

The KONTUR control units are available in three types:

The KONTUR-TRIO control unit serves for connection of up to three light curtains. In this case, different sensing field lengths and widths and different resolutions are allowed. Via DIP switches two different program modes "automated scanning" and "controlled scanning" may be selected (see Chapter 2.3).

The KONTUR-SOLO/XL control unit has the same functions and output characteristics except only one light curtain can be connected to.

The KONTUR-SOLO/p control unit serves for one light curtain and offers a low cost solution to the user, if only one sensing field is required. The KONTUR-SOLO/p control unit is designed exclusively for the program mode "automated scanning" (see Chapter 2.3.1) and provides reduced output data.

1.4 Interface to the Machine Control System

All, KONTUR-TRIO, KONTUR-SOLO/XL and KONTUR-SOLO/p control units are equipped with a parallel interface, which is electrically insulated by opto-coupler.

TRIO and SOLO/XL have 21 outputs and one input. SOLO/p has only 13 outputs. All in/outputs are opto-coupled. The outputs are designed as "open emitters" with max. 20 mA/40 V. The determined measured value is given out binary coded. Conducting opto-couplers correspond to logical "0" (the emitter conducts 24 V). Non-conducting opto-couplers correspond to logical "1" (the emitter is highly-resistive). The input current of the opto-coupler "open anode" is internally restricted to 10 mA/40 V. Figure 1-2 shows the interface of KONTUR-TRIO and SOLO/XL, Figure 1-3 presents the interface of KONTUR-SOLO/p.

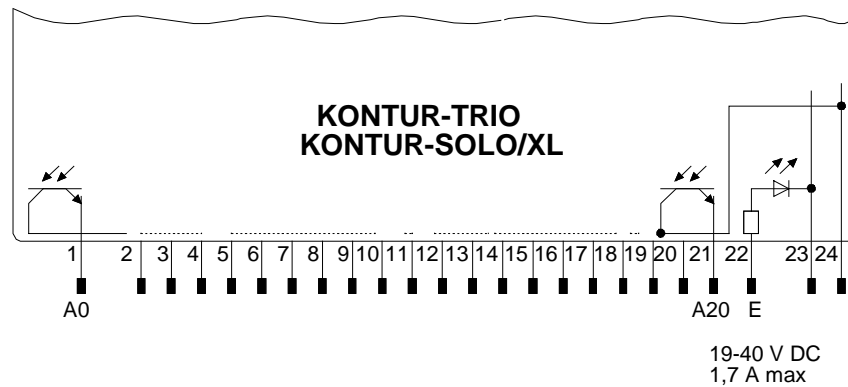

Fig. 1-2 The interface of KONTUR-TRIO and KONTUR-SOLO/XL

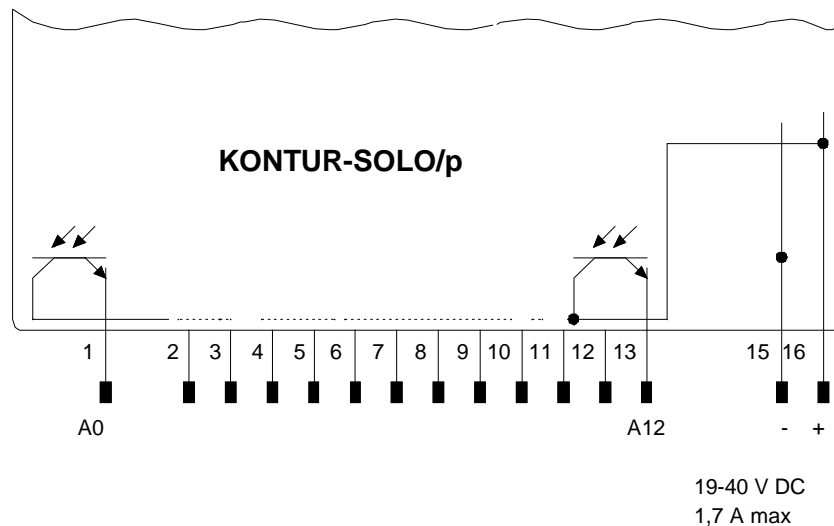

Fig. 1-3 The interface of KONTUR SOLO/p

1.5 Instructions for Appropriate Use



Caution:

The KONTUR measuring light curtain is **not** allowed to be used as an electro-sensitive protecting device (ESPD) to protect against bodily injuries at machines.

2 Design and Functions

2.1 Measuring Principle

The individual infrared light sources of the transmitter are activated one after the other, therefore, a mutual influence is excluded. The scanning cycle starts at the first diode next to the connector. An object entering into the sensing field leads to an interruption of the light beam(s) between transmitter and receiver. The status of the individual light beams "light path free" or "light path interrupted" is recognized by the internal processor. The status "light path free" is presented by a logical "1" (output of the associated opto-coupler highly-resistive). The status "light path interrupted" is presented by a logical "0" (output of the associated opto-coupler conductive).

Note: Reflective and mirror-like surfaces close to or in the light path may cause disturbances and a wrong detection and therefore it may lead to a faulty measurement. As remedial measures a perforated mask can be provided. However the maximum sensing range is then slightly reduced.

2.2 Measured Values and Data Preprocessing

2.2.1 Single Beam Information

The single beam information may be imagined as a serial data flow where each bit is associated with a light beam. By dividing this data flow into separate parts, parallel transferable segments are obtained (see Figure 2-1).

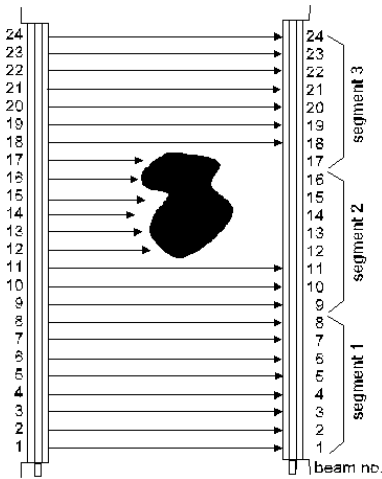

	single beam information								segment number					comment	
pin	1	2	3	4	5	6	7	8	9	10	11	12	13	14	
bit	0	1	2	3	4	5	6	7	0	1	2	3	4	5	
	1	1	1	1	1	1	1	1	0	0	0	0	0	1	seg 1 (20)
	1	1	1	0	0	0	0	0	1	0	0	0	0	1	seg 2 (21)
	0	1	1	1	1	1	1	1	0	1	0	0	0	1	seg 3 (22)
	1	1	1	1	1	1	1	1	0	0	0	0	0	1	seg 1 (20)
	1	1	1	0	0	0	0	0	1	0	0	0	0	1	seg 2 (21)
	⋮	⋮	⋮	⋮	⋮	⋮	⋮	⋮	⋮	⋮	⋮	⋮	⋮	⋮	⋮
	⋮	⋮	⋮	⋮	⋮	⋮	⋮	⋮	⋮	⋮	⋮	⋮	⋮	⋮	⋮

Fig. 2-1 Example for transmission of a serial data flow "Single beam information" in segments (data format = 8 bit)

2.2.2 Data Preprocessing

The control unit's microcontroller is designed to preprocess the measured values in advance before transferring to the machine control system. The following preprocessed data might be produced (see Figure 2-2).

- highest interrupted light beam (HU)
- highest not interrupted light beam (HNU)
- lowest interrupted light beam (TU)
- lowest not interrupted light beam (TNU)
- number of all interrupted light beams (ZU)
- number of all not interrupted light beams (ZNU)
- summary value (status)

HU, HNU, TU and TNU are each displayed by the ordering number of the related infrared beam (e.g. 1st beam ...01, 7th beam ...0111 and so on).

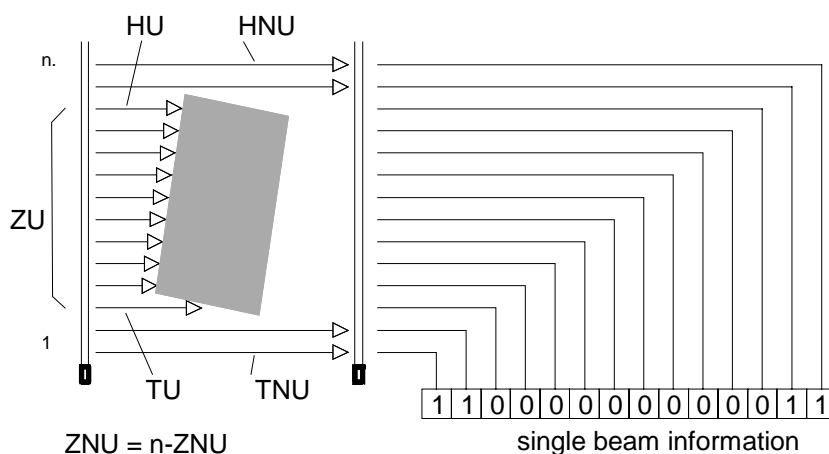

Fig. 2-2 Single beam information and preprocessed data

The preprocessed value "Status" consists of 8 bits with the following meanings:

- Bit 0 = 1, if the number of interrupted beams of KONTUR 1 is less than or equal to the number programmed as tolerance for measured values (see Chapter 2.3.1)
- Bit 1 = 1, if all light beams of KONTUR 1 are interrupted. When only a single light path is free, this bit changes.
- Bit 2 equal to Bit 0, yet for KONTUR 2
- Bit 3 equal to Bit 1, yet for KONTUR 2
- Bit 4 equal to Bit 0, yet for KONTUR 3
- Bit 5 equal to Bit 1, yet for KONTUR 3
- Bit 6 = 1, if Bit 0 AND Bit 2 AND Bit 4 are set, to say that all connected KONTUR optical components notify free light paths. This information might be helpful during installation to check the alignment of the optical components.
- Bit 7 = 1, if Bit 1 OR Bit 3 OR Bit 5 are set, to say that at least one light curtain is completely interrupted.

2.3 Automated or Controlled Scanning?

Via a DIP-switch on the printed circuit board of the KONTUR-TRIO or KONTUR-SOLO/XL can be decided between two program modes. In mode "Automated scanning" the device starts scanning the sensing field automatically after switching on power supply. As soon as the sensing field is scanned completely the determined measured value is presented on the outputs. Thereafter a new scan starts.

Using the mode "Controlled scanning" the scan through the sensing field is stimulated by a status change (trigger signal at the input E of the interface). With each status change a part of the sensing field (as large as the segments are defined) is scanned, evaluated and presented. Thus, the timing of the scanning can be determined directly by the subsequent machine control system. Figure 2-3 shows a flow chart of the two program options.

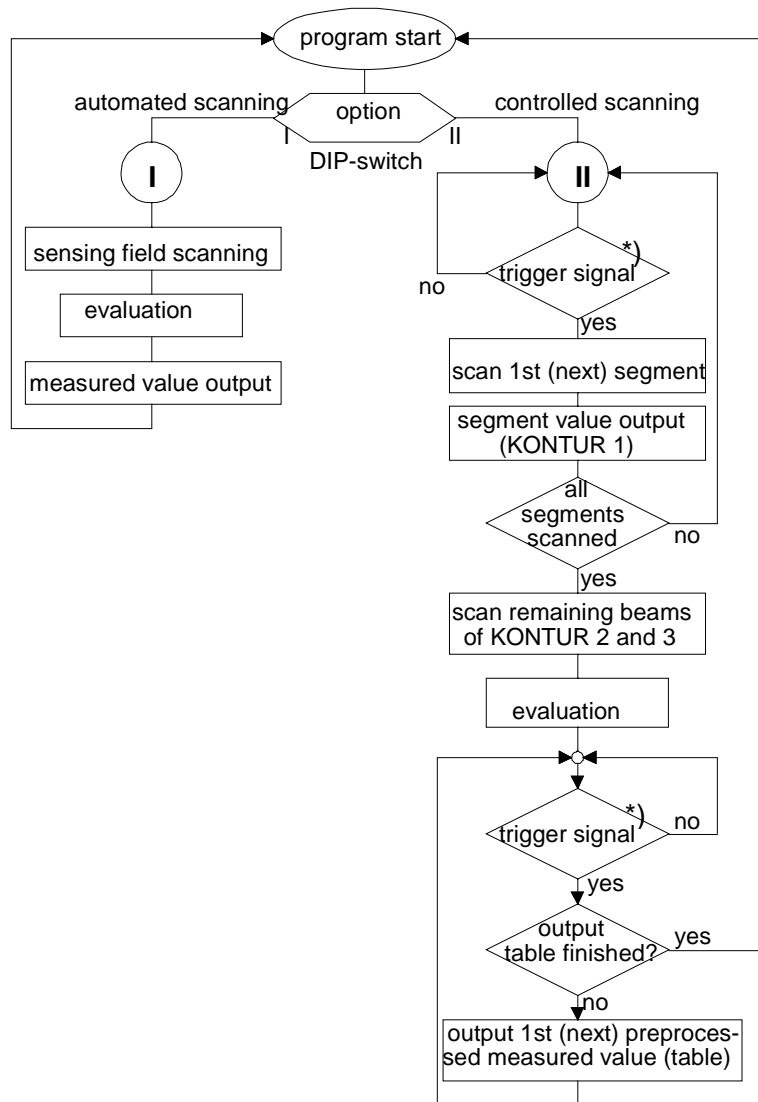

*) If the result of parameterizing leads to only one segment that will be given out, it is not necessary to generate a trigger signal. Because this single segment data is automatically updated.

Fig. 2-3 Program flow chart

Table 2.1 shows the optional program modes and the related setting of the DIP-switches.

Program modes	Switch Settings			
	Switch no. 1	Switch no. 2	Switch no. 3	Switch no. 4
Automated scanning (Option I)	ON	OFF	OFF	OFF
Controlled scanning (Option II, KONTUR-TRIO and KONTUR-SOLO/XL only!)	OFF	ON	OFF	OFF
Opto-coupler test	OFF	OFF	OFF	ON
Continuous output of the measured value HU of the Light Curtain 1 (KONTUR-SOLO/p only!)	ON	OFF	OFF	ON

Table 2-1 The DIP-switch of KONTUR-SOLO/p or TRIO and SOLO/XL

2.3.1 Automated Scanning (Option I)

Automated scanning provides max. three preprocessed measured values at the same time by using KONTUR-TRIO and KONTUR-SOLO/XL but only one by using KONTUR-SOLO/p. Which kind of preprocessed measured value should be presented can be determined by the user via an entry of an identification number into the EPROM register. The assignment of the identification numbers and their meanings is shown in Table 2-2 on pages 13 and 14.

The data field length of the preprocessed measured values depends on the beam numbers of the related light curtains and must not exceed 21 bits for KONTUR-TRIO and 13 bits for KONTUR-SOLO/p. The individual measured values are stringed together, each starting to the right with Bit 0. Using the Option I (automated scanning) the output of single beam information is not possible.

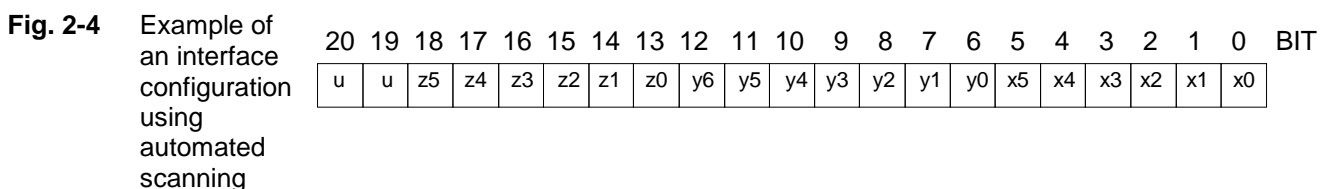

x0 - x5 output data 1 (address 1C18H) of a "6-Bit" KONTUR light curtain

y0 - y6 output data 2 (address 1C19H) of a "7-Bit" KONTUR light curtain

z0 - z5 output data 3 (address 1C1AH) of a "6-Bit" KONTUR light curtain

u stands for "not used"

The input E retains unconnected in case of automated scanning.

2.3.2 Controlled Scanning (Option II)

As described above under paragraph 2.2.1 the light beams of the sensing field are divided into individual segments which are scanned and transmitted one after the other. Simultaneously with the single beam information of the segment the associated identification number is transmitted to assure allocation of segments by the subsequent machine control unit. The identification number of the 1st segment to be transmitted is 20H, all ensuing segments are numbered gradually. Figure 2-5 shows an example of a possible configuration using the controlled output option.

Fig. 2-5 Example of a interface configuration using controlled scanning

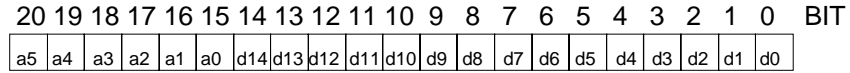

d0 - d14 Segment data
a0 - a5 Segment identification number

The input E serves as trigger input for segment scan start.

2.4 KONTUR Control Units

The KONTUR control unit contains power supply, sensor controller, signal evaluation and the interface to the subsequent machine control system (see Chapters 1.3 and 1.4). It is available in three different types: KONTUR-TRIO, KONTUR-SOLO/XL and KONTUR-SOLO/p. Which one should be chosen depends mainly on the application to be solved.

The KONTUR-TRIO is preferably used if more than one sensing field has to be scanned simultaneously or in cases of complex contours (with openings e.g. window frames) should be measured (see Chapter 4 incl. Figure 4-1). The KONTUR-TRIO permits the choice of deciding between "automated scanning" and "controlled scanning".

The KONTUR-SOLO/XL is preferably used where only one light curtain is used but complex output data is needed. KONTUR-SOLO/XL output characteristics are the same as the KONTUR-TRIO ones.

The KONTUR-SOLO/p is preferably used for applications where only one sensing field is necessary and the measurement of the object's outline shape is sufficient. KONTUR-SOLO/p is a low cost version but it is restricted to the program mode "automated scanning" (see also Chapter 3 incl. Figure 3-1)

2.5 Configuration of Measured Value Output

The software of the KONTUR may be adapted by parametrizing accordingly an EPROM to the specification of the light curtain (e.g. number of beams), to the data field length of a PLC input board and to the request of a specific application.

The KONTUR control unit use 8k x 8 EPROMs type 27C64. These memory chips may be adapted via a common programmer either by the user or by Leuze lumiflex. This kind of software adaption offers the possibility to follow changing measurement tasks easily and quickly.

2.5.1 Programmable Parameters and their Meanings

Beam number:

The parameter „beam number“ is related to the number of beams of the respective optical component. The KONTUR-TRIO offers three terminals to connect up to three KONTUR light curtains KONTUR 1, KONTUR 2 and KONTUR 3. If there are less than three KONTUR light curtains connected, the related beam number of the not connected light curtains must be set to 00. When assigning the light curtains to the terminals, attention must be paid to the different time consumption according to table 2-5. Only KONTUR 1 is able to compute a beam number greater than 256.

Control interval:

The parameter „control interval“ determines the spacing of the control. If only every second or third light beam should be activated, this parameter has to be set according to the following table.

KONTUR type	Value
KTxxx10	01
KTxxx20	02
KTxxx40	04

Tolerance for sensing field status indication:

The KONTUR receiver comprise a sensing field status display which indicates if the complete sensing field is free or if an object intrudes. This indication is intended to support alignment - it can easily be seen if all light beams are received with sufficient energy. Are one or more light beams constantly interrupted by an intruding object (e.g. mounting device) their number may be programmed as a tolerance. In this case, the sensing field status display changes only if more than the programmed number of light beams are interrupted. However, the output values of the data interface remain unchanged. This "blanking" is only relevant for the sensing field status indication and for the output value „status“. The standard parameter for the tolerance is 00.

Offset:

The parameter "offset" determines the number of light beams which should be skipped at the beginning of a scan. The standard parameter for offset is 00.

Identification number of output data:

All output data (preprocessed measured values or segments of single beam information) are designated with an identification number. These identification numbers have to be put in as parameters in a corresponding sequence to achieve the preferred interface assignment and the configuration of the measured values. (see table 2-4)

Group counter:

This parameter allows a reduction of the data to be transmitted, yet at the expense of image resolution. The minimum resolution of the light curtain is nevertheless maintained. In order to achieve this data reduction, several of the adjacent single beams are grouped together to one Bit (OR operation). As soon as only one beam of the group is interrupted this Bit is set. The group counter is preset to 01 and only applicable for controlled scanning (Option II).

Data format:

If controlled scanning is selected, the data format is adaptable to the number of inputs of the subsequent control system (PLC). Smaller data formats lead to an increased number of segments and, as a result, to a possibly larger data format of the identification number.

Output table:

This part of the parameter field has to be filled with the identification numbers of output data in the sequence, in which they are read out by the subsequent control system (see Table 2-4, address 1C20H - 1C3FH). If the output of single beam information via segments is needed, the identification number of the segment output must be placed at the first line (1C20H) of the output table. The end of the output table has to be marked by entry of 1DH (end of block). This end mark is not subject to be transmitted.

Company code:

A code specific for each company with a customized program.

PLC cycle time:

Adaption of the data output sequence of the KONTUR control unit to the PLC cycle time. When chosen, the refresh interval of output data is double the PLC cycle time.

Min/max values:

Value of the lowest or highest interrupted beam held during a certain time (hold time) at the outputs. This function is similar to a peak detection function.

E.g. if after each scan the lowest interrupted beam is lower than the one before the output min value reflects the actual state. But if after each scan the lowest interrupted beam is higher than the one before the output min value will only be refreshed after a certain time (hold time).

Vice versa for max values.

2.5.2 Table of Beam Numbers in Hexadecimal Notation

The Table 2-2 lists the beam numbers of the various KONTUR optical units in hexadecimal notation. The according beam numbers must be put into the parameter field (address 1C00H - 1C04H), considering that only one KONTUR light curtain (e.g. KONTUR 1) may exceed 255 beams.

KONTUR type "10 mm"	KONTUR type "20 mm"	KONTUR type "40 mm"	Beam number (hex.) for Table 1C00 - 1C04	Beam number (dec.) effective
		K1240	00 0C h	03
	K1220		00 0C h	06
		K2440	00 18 h	06
		K3640	00 24 h	09
K1210			00 0C h	12
	K2420		00 18 h	12
		K4840	00 30 h	12
		K6040	00 3C h	15
	K3620		00 24 h	18
		K7240	00 48 h	18
		K8440	00 54 h	21
K2410			00 18 h	24
	K4820		00 30 h	24
	K6020		00 3C h	30
		K9640	00 60 h	24
		K10840	00 6C h	27
	K7220		00 48 h	36
		K12040	00 78 h	30
		K13240	00 84 h	33
K3610			00 24 h	36
	K8420		00 54 h	42
		K14440	00 90 h	36
		K15640	00 9C h	39
	K9620		00 60 h	48
		K16840	00 A8 h	42
		K18040	00 B4 h	45
K4810			00 30 h	48
	K10820		00 6C h	54
		K19240	00 C0 h	48
		K20440	00 CC h	51
	K12020		00 78 h	60
		K21640	00 D8 h	54
		K22840	00 E4 h	57
K6010			00 3C h	60
	K13220		00 84 h	66
		K24040	00 F0 h	60
		K25240	00 FC h	63
	K14420		00 90 h	72
		K26440	0 108 h	66
		K27640	0 114 h	69

Table 2-2 Beam numbers in hexadecimal notation

KONTUR type "10 mm"	KONTUR type "20 mm"	KONTUR type "40 mm"	Beam number (hex.) for Table 1C00 - 1C04	Beam number (dec.) effective
K7210			00 48 h	72
	K15620		00 9C h	78
		K28840	0 120 h	72
		K30040	0 12C h	75
	K16820		00 A8 h	84
K8410			00 54 h	84
	K19220		00 C0 h	96
K9610			00 60 h	96
	K20420		00 CC h	102
	K21620		00 D8 h	108
K10810			00 6C h	108
	K22820		00 E4 h	114
	K24020		00 F0 h	120
K12010			00 78 h	120
	K25220		00 FC h	126
	K26420		0 108 h	132
K13210			00 84 h	132
	K27620		0 114 h	138
	K28820		0 120 h	144
K14410			00 90 h	144
	k30020		01 2C h	150
K15610			00 9C h	156
K16810			00 A8 h	168
K18010			00 B4 h	180
K19210			00 C0 h	192
K20410			00 CC h	204
K21610			00 D8 h	216
K22810			00 E4 h	228
K24010			00 F0 h	240
K25210			00 FC h	252
K26410			01 08 h	264
K27610			01 14 h	276
K28810			01 20 h	288
K30010			01 2C h	300

Table 2-2 Beam numbers in hexadecimal notation (page 2 of 2)

2.5.3 Identification Number of Output Values

As mentioned before, all data which should be given out (preprocessed measured values or segments of single beam information) must be designated by an identification number. These identification numbers must be put into the EPROM parameter field in desired sequence. Table 2-3 shows the association between identification numbers and output values.

Ident. no.	Short name	Remark
00 h	BUSY	
01 h	HU -K1	highest interrupted light beam of KONTUR 1
02 h	HNU-K1	highest not interrupted light beam of KONTUR 1
03 h	TU -K1	lowest interrupted light beam of KONTUR 1
04 h	TNU-K1	lowest not interrupted light beam of KONTUR 1
05 h	ZU -K1	number of all interrupted beams of KONTUR 1
06 h	ZNU-K1	number of all not interrupted beams of KONTUR 1
07 h	n -K1	beam number of KONTUR 1 (according to 1C00h, 1C01h)
08 h	Status	(see above mentioned description) data format 8 Bit constant
09 h		
0A h	HU -K2	highest interrupted light beam of KONTUR 2
0B h	HNU-K2	highest not interrupted light beam of KONTUR 2
0C h	TU -K2	lowest interrupted light beam of KONTUR 2
0D h	TNU-K2	lowest not interrupted light beam of KONTUR 2
0E h	ZU -K2	number of all interrupted beams of KONTUR 2
0F h	ZNU-K2	number of all not interrupted beams of KONTUR 2
10 h	n -K2	beam number of KONTUR 2 (according to 1C02h)
11 h		
12 h		
13 h	HU -K3	highest interrupted light beam of KONTUR 3
14 h	HNU-K3	highest not interrupted light beam of KONTUR 3
15 h	TU -K3	lowest interrupted light beam of KONTUR 3
16 h	TNU-K3	lowest not interrupted light beam of KONTUR 3
17 h	ZU -K3	number of all interrupted beams of KONTUR 3
18 h	ZNU-K3	number of all not interrupted beams of KONTUR 3
19 h	n -K3	beam number of KONTUR 3 (according to 1C04h)
1A h		
1B h		
1C h	Prog.-Vers.	(codified) data format 8 Bit constant
1D h	Block end	must be written into output table
1E h	Parameter failure	Option II only
1F h	System failure	Option II only
20 h	Segment 1	single beam information of KONTUR 1
21 h	Segment 2
22 h	Segment 3
23 h	segment 4
24 h	Segment 5
...	Segment

Table 2-3 Identification number of output values in hexadecimal notation
(page 2 of 2)

2.5.4 The Programmable Part of the Program Register

Table 2-4 shows the programmable part of the KONTUR control unit's EPROM. At the corresponding addresses starting at 1C00h through 1C4Fh, the requested identification numbers are put in using hexadecimal notation.

Table 2-4 Program table for KONTUR-SOLO/p

SOLO/p		Order No.: ##				
Customer: ##		Serial No.: ##				
Program: SOLO V1.10			Adresse	Standard	Data	Comment
Option I	Shift register (according to table)	LBYTE	1C00h	00h	###	Typ: K#####
		HBYTE	1C01h	00h	###	
	Control interval		1C06h	01h	###	
	Tolerance of sensing field indication		1C09h	00h		
	Offset (unused SR-FFs at the beginning)		1C0Ch	00h		
	Blanks (unused SR-FFs at the end)		1C0Fh	00h		
	Minimum size of gap		1C16h	00h		
	Output code parameter 0 = binary, 1 = graycode		1C17h	00h		
	Ident no. of output values (according to table)		1C18h	03h	##	TU
	PLC cycle time [ms]		1C1Ch	00h	##	fast

Interface pin assignment

	Pin	Description
Bit - 0	1	Output value
Bit - 1	2	Output value
Bit - 2	3	Output value
Bit - 3	4	Output value
Bit - 4	5	Output value
Bit - 5	6	Output value
Bit - 6	7	Output value
Bit - 7	8	Output value
Bit - 8	9	Output value
Bit - 9	10	Status (alle received)
Bit - 10	11	Status (alle interrupted)
Bit - 11	12	Trigger output, change after each scan
Bit - 12	13	0, if gap detected
reserved	14	
Gnd	15	power supply (ground)
+ 24Vdc	16	power supply (ground)

Output values

Ident no.	Abbreviation	Description
01h	HU	highest interrupted beam
02h	HNU	highest non interrupted beam
03h	TU	lowest interrupted beam
04h	TNU	lowest non interrupted beam
05h	ZU	number of all interrupted beams
06h	ZNU	number of all non interrupted beams
09h	HU - TU + 1-LSZ	

Table 2-5 Program table for KONTUR-SOLO/XL

SOLO XL			Order number ##					
Customer: ##			Serial number ##					
Program: SOLO XL V1.45				Adress	Standard	Data	Comment	
Option I + II	Shift register (according to table)	KONTUR 1	LBYTE	1C00h	00h	###	Type: K#####	
			HBYTE	1C01h	00h	###		
		KONTUR 2		1C02h				
				1C03h				
			KONTUR 3		1C04h			
				1C05h				
	Control interval	KONTUR 1		1C06h	01h			
		KONTUR 2		1C07h				
		KONTUR 3		1C08h				
	Tolerance of sensing field indication	KONTUR 1		1C09h	00h			
		KONTUR 2		1C0Ah				
		KONTUR 3		1C0Bh				
	Offset (unused SR-FFs at the beginning)	KONTUR 1		1C0Ch	00h			
		KONTUR 2		1C0Dh				
		KONTUR 3		1C0Eh				
							
							
					
Option I	Ident no. of output values (according to table)	Output value 1		1C18h	03h		TU-K1	
		Output value 2		1C19h	01h		HU-K1	
		Output value 3		1C1Ah	08h		status	
	Company code			1C1Bh	00h		standard	
	PLC cycle time [ms]			1C1Ch	00h		fast	
				1C1Dh				
	Hold time for min/max value			1C41h	32h (500ms)			
	min, max, normal (1,2,FF)	for output value 1		1C42h	FFh (normal)			
	min, max, normal (1,2,FF)	for output value 2		1C43h	FFh (normal)			
min, max, normal (1,2,FF)	for output value 3		1C44h	FFh (normal)				
Option II	Group counter	KONTUR 1		1C1Eh	01h [1...255]			
	Data format	(8 - 21) Bit		1C1Fh	0Fh (15 Bit)			
	Start of output table				1C20h	20h Segment		
					1C21h	1Dh standard		
					1C22h			
					1C23h			
					1C24h			
					1C25h			
							
							
							
			1C3Fh					

Interface pin assignment in the mode of automated scanning

Pin	1	2	3	4	5	6	7	8	9	10	11	12	13	14	15	16	17	18	19	20	21	22	23	24	
Bit																							E	Gnd	+24
Output Value																									

TRIO			Order number ##					
Customer: ##			Serial number ##					
Program: TRIO V1.45			Address	Standard	Data	Comment		
Option I + II	Shift register (according to table)	KONTUR 1	LBYTE	1C00h	00h	###	Type: K#####	
			HBYTE	1C01h	00h	###		
		KONTUR 2	LBYTE	1C02h	00h	###	Type: K#####	
				1C03h				
		KONTUR 3	LBYTE	1C04h	00h	###	Type: K#####	
				1C05h				
	Control interval	KONTUR 1		1C06h	01h			
		KONTUR 2		1C07h	01h			
		KONTUR 3		1C08h	01h			
	Tolerance of sensing field indication	KONTUR 1		1C09h	00h			
		KONTUR 2		1C0Ah	00h			
		KONTUR 3		1C0Bh	00h			
	Offset (unused SR-FFs at the beginning)	KONTUR 1		1C0Ch	00h			
		KONTUR 2		1C0Dh	00h			
		KONTUR 3		1C0Eh	00h			
							
							
							
Option I	Ident no. of output values (according to table)	Output value 1		1C18h	03h		TU-K1	
		Output value 2		1C19h	0ch		TU-K2	
		Output value 3		1C1Ah	15h		TU-K3	
	Company code			1C1Bh	00h		standard	
	PLC cycle time [ms]			1C1Ch	00h		fast	
				1C1Dh				
	Hold time for min/max value			1C41h	32h (500ms)			
	min, max, normal (1,2,FF)	for output value 1		1C42h	FFh (normal)			
	min, max, normal (1,2,FF)	for output value 2		1C43h	FFh (normal)			
	min, max, normal (1,2,FF)	for output value 3		1C44h	FFh (normal)			
Option II	Group counter	KONTUR 1		1C1Eh	01h [1...255]			
	Data format	(8 - 21) Bit		1C1Fh	0Fh (15 Bit)			
	Start of output table				1C20h	20h Segment		
					1C21h	0Ch TU - K2		
					1C22h	15h TU - K3		
					1C23h	1Dh standard		
					1C24h			
					1C25h			
							
							
							
				1C3Fh				

Interface pin assignment in the mode of automated scanning

Pin	1	2	3	4	5	6	7	8	9	10	11	12	13	14	15	16	17	18	19	20	21	22	23	24	
Bit																							E	Gnd	+24
Output Value																									

Table 2-6 Program table for KONTUR-TRIO

2.6 Time Needed for a Complete Measuring Cycle

If more than one KONTUR light curtain is connected to a KONTUR-TRIO control unit, the sensing fields of the individual light curtains are not scanned one after the other, but on the contrary, almost simultaneously. Starting with all first beams, each of them shifted marginally in time, all second and all third beams (and so on) are scanned. This leads to the advantage, that in case of 3 light curtains, the time needed is considerably shorter compared to a sequential mode. In addition, the time needed per infrared beam depends on the slot used (1, 2 or 3) for the individual light curtains. There are seven possible combinations. Table 2-5 shows the combinations and the related time consumption per light beam for KONTUR-TRIO. The connection of a light curtain at a certain slot is marked by an "x". Using KONTUR-SOLO/p the time needed per infrared beam is independent of the number of beams. Its about 100 μs per beam.

Slot (Parameters must be put in accordingly)			Combinations	Time consumption per beam (T_{scan})	
KONTUR 1	KONTUR 2	KONTUR 3		automated scanning	controlled scanning
		X	1	$t_1 \sim 100 \mu\text{s}$	110 μs
	X		2	$t_2 \sim 100 \mu\text{s}$	110 μs
	X	X	3	$t_3 \sim 130 \mu\text{s}$	140 μs
X			4	$t_4 \sim 130 \mu\text{s}$	190 μs
X		X	5	$t_5 \sim 170 \mu\text{s}$	230 μs
X	X		6	$t_6 \sim 170 \mu\text{s}$	230 μs
X	X	X	7	$t_7 \sim 210 \mu\text{s}$	270 μs

Table 2-7 Time needed per infrared beam at different combinations

Usually the connected KONTUR light curtains are different in length respectively they have different beam numbers. This leads to a different time consumption within different areas of the sensing field. Figure 2-6 shows the time consumption of different KONTUR combinations.

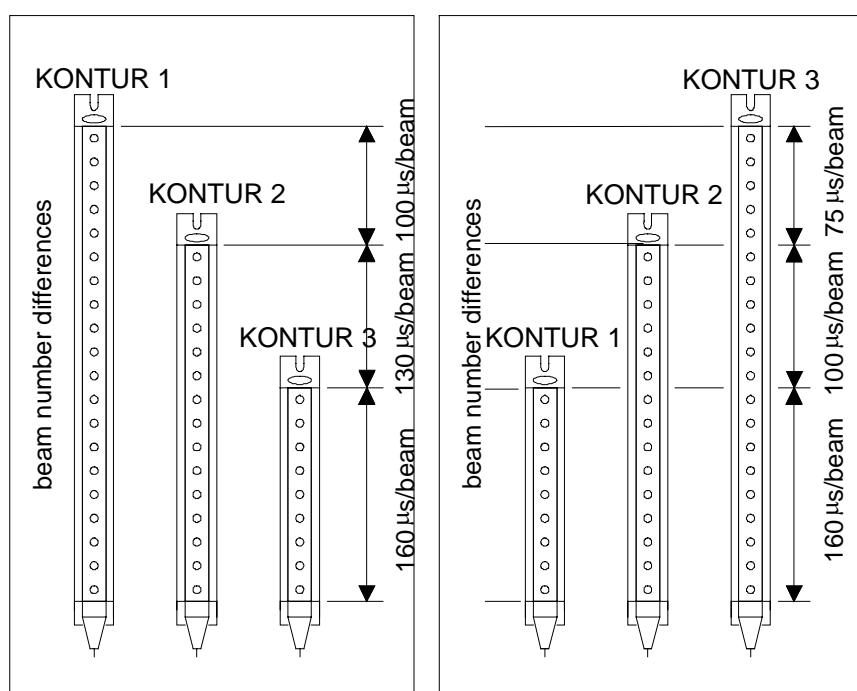

Fig. 2-6 Time consumption of different KONTUR combinations

2.6.1 Time Needed for Automated Scanning

Using automated scanning (Option 1) the duration of a complete scan cycle (T_{cycle}) is an addition of the actual measuring field scanning time (T_{scan}), the evaluation time (t_{calc}) and the output time (T_{out}).

$$T_{cycle} = T_{scan} + T_{calc} + T_{out}$$

T_{cycle} would be calculated for the example in Table 2-7, left side:

$$T_{scan} = (d1 * 100 + d2 * 130 + d3 * 160) \mu s$$

$$T_{calc} = n_{max} * 15 \mu s$$

$$T_{out} = 800 \mu s$$

n_{max} = beam number of the longest light curtain

2.6.2 Time Needed for Controlled Scanning

Using controlled scanning (Option II) the time needed for scanning of one segment depends on the data format (1C1Fh), the format of the group counter (1C1Eh) (to say number of beams per segment) and further more of the selected KONTUR combination and the related time consumption per beam.

$$T_{segment} = n_{segment} * T_{scan}$$

$n_{segment}$: number of beams per segment

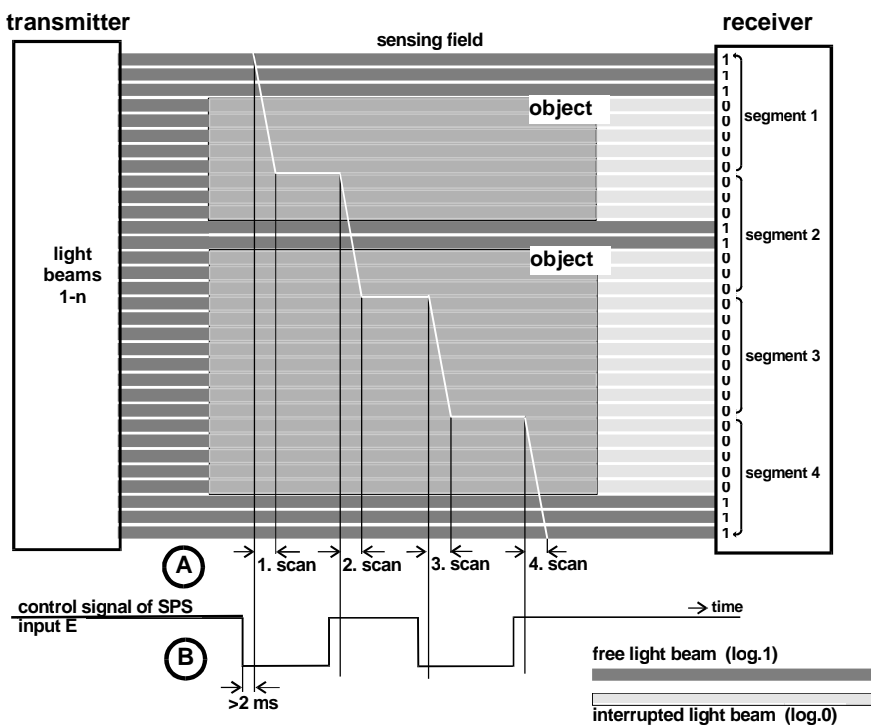

- (A) Every segment is sequentially scanned and given parallel to the output.
- (B) Every trigger signal on input E provided by the PLC starts the next scan.

Fig. 2-7 Example for controlled scanning (output of the single beam information with 4 segments, 8 bit each)

3 Application Examples for Automated Scanning

3.1 Principle Criteria of Use

After switching the supply voltage, the scanning of the measuring field starts automatically. At the time all light beams of the connected KONTUR light curtains are scanned once, the evaluated measured value is available at the data interface of the KONTUR control unit. This measured value is held until the next measured value is evaluated. As described earlier, during this mode of scanning only preprocessed data is given out. Single beam information is not available in this mode (compare with Figure 2-1). For this reason the suited applications using automated scanning are mainly the evaluation of external object shapes. Holes within those objects cannot be detected.

3.2 Application Examples

Figure 3-1 shows some examples for KONTUR using automated scanning.

Fig. 3-1 Examples for KONTUR using automated scanning

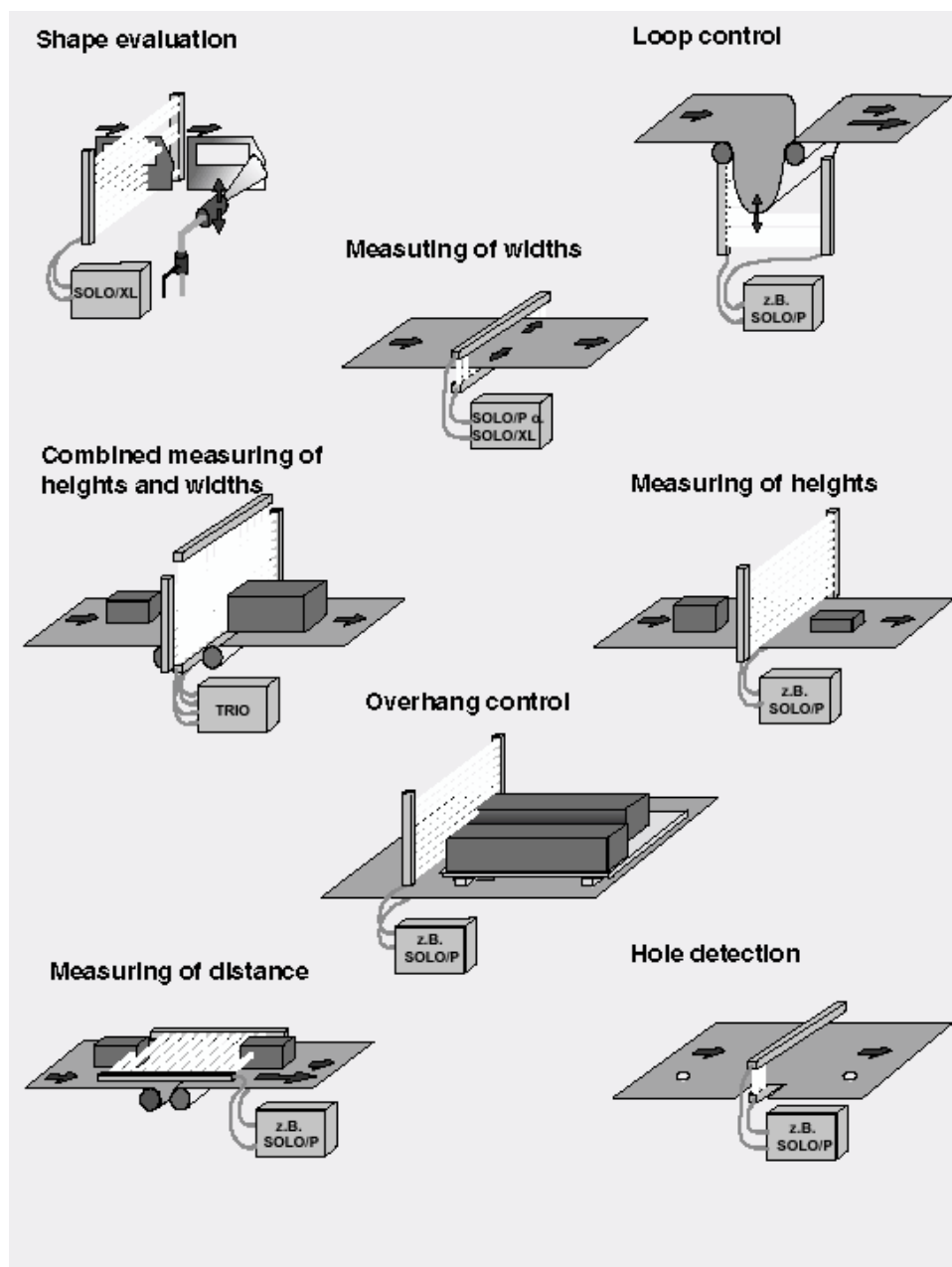

4 Application Examples for Controlled Scanning

4.1 Principle Criteria

Using controlled scanning the measured field created by the optical components is divided into segments. On request by a subsequent control system one segment will be scanned and given out at the same time. This scanning mode offers to the subsequent control system the possibility to evaluate the state of each of the single beams. This mode allows to determine, where and how many light beams are interrupted by an object. Thus, holes within objects can be evaluated.

4.2 Application Examples

Figure 4-1 shows some examples for KONTUR using controlled scanning.

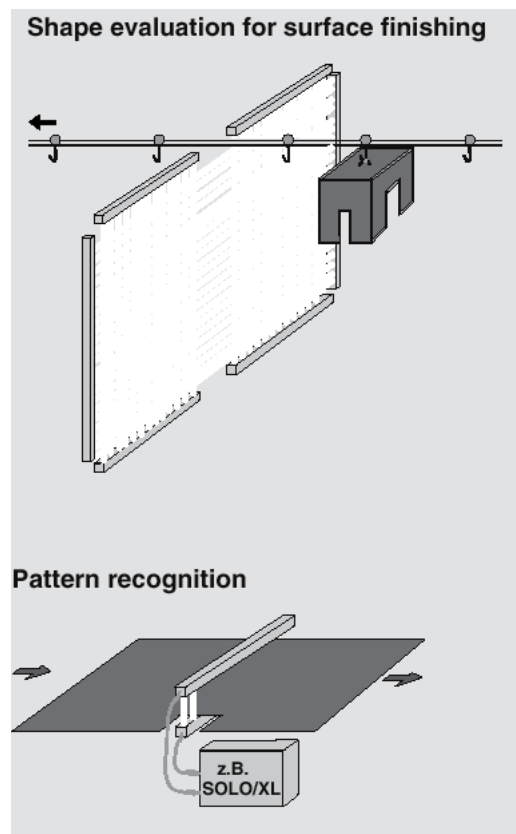

Fig. 4-1 Examples for KONTUR using controlled scanning.

5 Fitting

Transmitter and receiver are mounted on both sides of the sensing field at the same height. Tension-free mounting is important to prevent from twisting or damaging of the optical units. Uneven base should be levelled by using washers. The distance between transmitter and receiver should not exceed 3.5 m. Mounting of transmitter and receiver is made by the angle pieces on both ends. The position of the mounting holes is shown in the Dimensional Drawing 12.2 and Dimension Table 12.3 (Appendix). There are four drill holes to mount the KONTUR control units, which are accessible after removing the cover of the housing. Positions and dimensions of the mounting holes are described in Appendix: Dimensional Drawings and Dimension Tables.

Note: For light curtains longer than 2 m (from K216xx on) an additional reinforcement profile is already mounted (see figure 11-1).

6 Electrical Connection

6.1 Connection Optical Units - Control Unit

The connection between the KONTUR optical units and the control unit consists of connection cables with connectors on both ends. These connecting cables are ready-made and available in lengths of 1 m, 2.5 m, 5 m, 10 m and 20 m. Transmitter and receiver require one connecting cable each.

6.2 Connection to the Machine Control System

Heavy plug-in connectors with 24 pins + PE for KONTUR-TRIO, KONTUR-SOLO/XL and with 16-pins + PE for KONTUR-SOLO/p are provided for connecting the lead to the machine control system. They contain socket inserts with screw-type terminals, suitable for core cross sections of 0.5 to 2.5 mm. To prevent the data connection from electro-magnetic interference, only shielded cables should be used. The core cross section should not fall below 0.5 mm. Figure 6-1 shows an example for the connection of KONTUR-TRIO, KONTUR-SOLO/XL, Figure 6-2 for the connection of KONTUR-SOLO/p.

Fig. 6-1 Example for the connection of KONTUR-TRIO, KONTUR-SOLO/XL

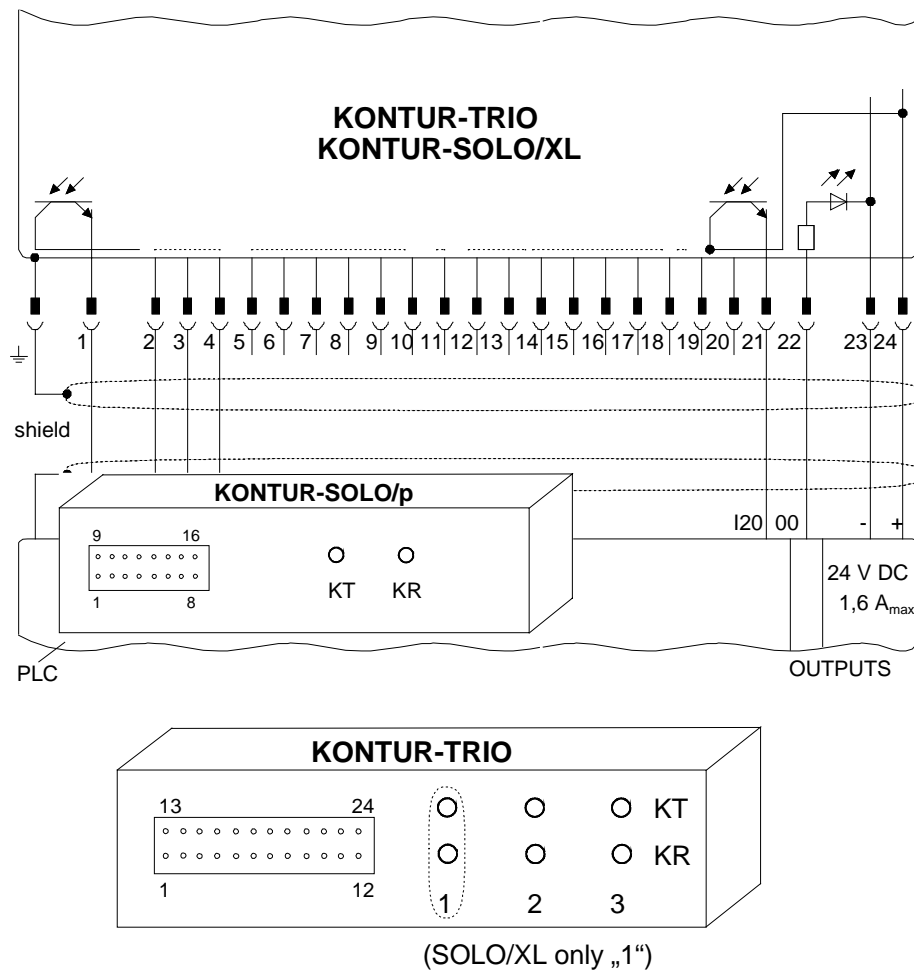

Fig. 6-2 Example for connection of KONTUR-SOLO/p

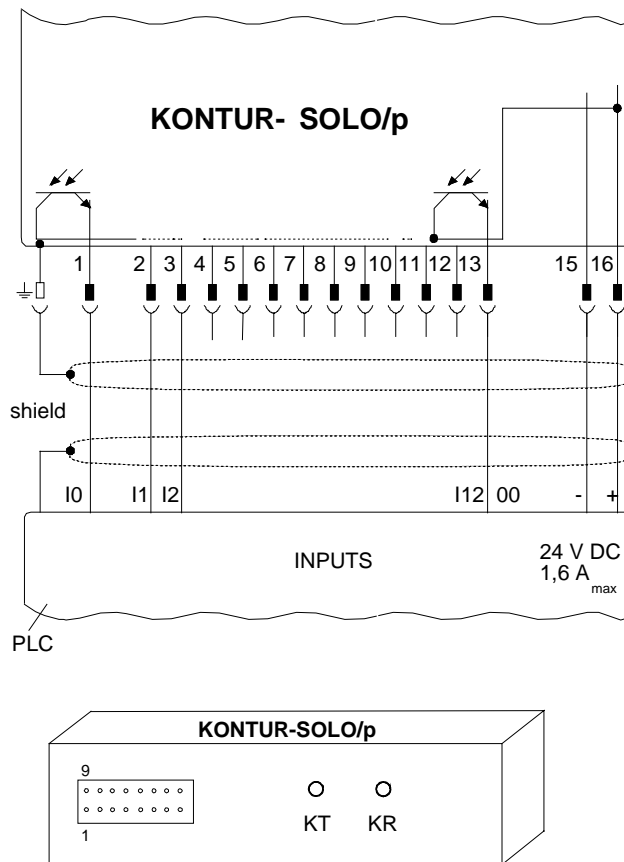

Fig. 6-2 Example for connection of KONTUR-SOLO/p

7 Start-Up

7.1 Display Elements

All display elements of KONTUR are located underneath the red front screens.

The transmitter controls one LED. This LED is lighted up when the transmitter is accidentally connected to the terminals of the control unit where normally only the receiver should be connected. If the cable is plugged correctly, the LED is switched off.

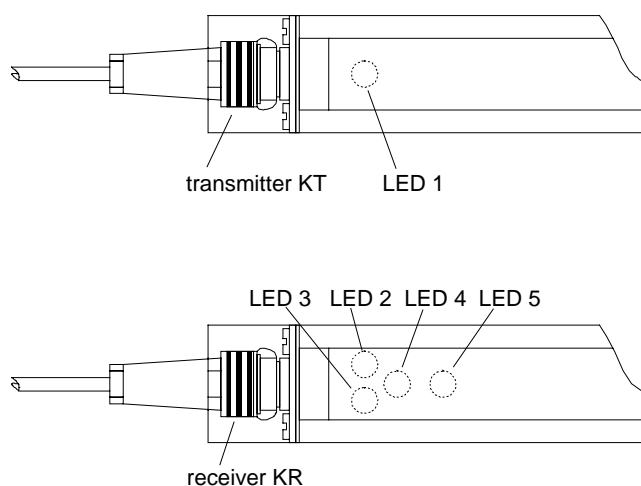

○ All LED are located underneath the red front screens.

Fig. 7-1 Display elements of KONTUR optical units

The receiver controls four LEDs. If the receiver accidentally is connected to the transmitter's plug at the control unit, the four LEDs light commonly. If the receiver is plugged correctly, only two LEDs light, depending on the status of the sensing field. Table 7-1 shows the function and meaning of the display elements.

LED-No	Colour	Status	Meaning
1	red	OFF	Transmitter <u>correctly</u> connected to plug KT1, KT2 or KT3
1	red	ON	Transmitter <u>incorrectly</u> connected to receiver's plug KR1, KR2 or KR3
2,3	red	OFF	No object in the sensing field Sensing field free
2,3	red	ON	An object interrupts the sensing Sensing field not free
4,5	red	OFF	An object interrupts the sensing Sensing field not free
4,5	red	ON	No object interrupts the sensing field Sensing field free

Table 7-1

7.2 Checks before Initial Operation

Before switching on the first time, check whether the local supply voltage corresponds to the supply voltage of the KONTUR control unit as indicated on the type plate.

7.3 Aligning Transmitter and Receiver

In order to achieve trouble-free operation of the equipment, the light beam of the transmitter must hit the receiver symmetrically. The receiver itself must be aligned towards the transmitter. For the purpose of alignment, loose the mounting screws until the optical components become movable. Proceed as follows:

1. Put the transmitter (e.g. with the help of a lever tube) into basic position.
2. Now turn the receiver until the LEDs 4 and 5 switch on.
3. Turn beyond this point until LEDs 4 and 5 switch off again.
4. Now swing back again and fasten the receiver at the center of this range.
5. Turn the transmitter until the LEDs 4 and 5 of the receiver switch off.
6. Turn back until LEDs 4 and 5 switch on again.
7. Swing beyond this point until LEDs 4 and 5 switch off again. Then swing back and fasten the transmitter in the center of this range. The same procedure is valid for all of the connected optical units.

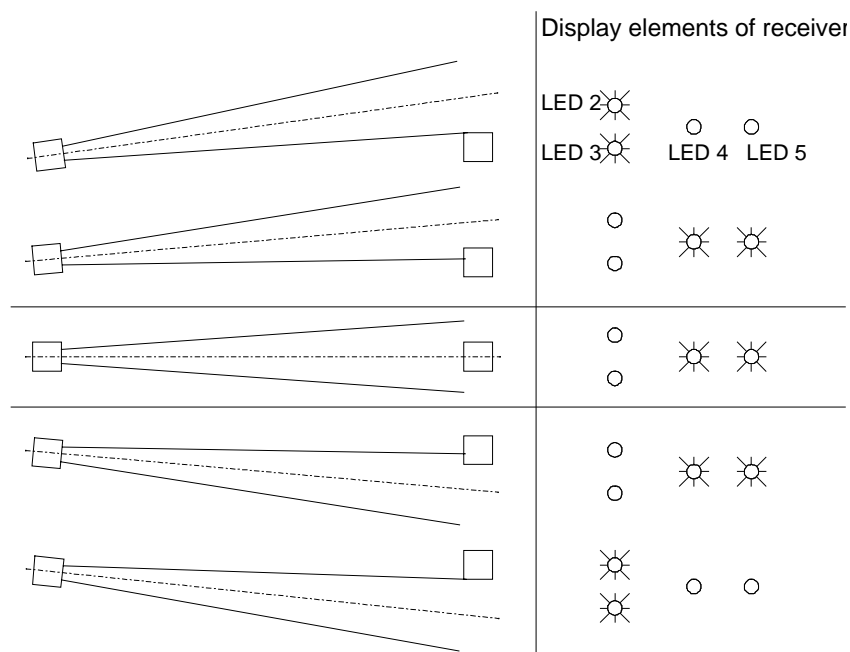

Fig. 7-2 Alignment of transmitter and receiver

8 Troubleshooting and Fault Rectification

Malfunctions often have relatively simple causes. The following Table 8-1 serves as an instruction for troubleshooting and fault rectification. If this does not work, contact LUMIFLEX service department or the authorized factory representative.



Caution: Do not touch electrical connections when the equipment is open and switched on!

Symptom	Possible Cause	Check/Remedy
All displays in transmitter and receiver will not light	<ul style="list-style-type: none"> – No supply voltage 	<ul style="list-style-type: none"> – Turn on main power supply (e.g. on the machine) – Check connectors at KONTUR control unit
LED1 of transmitter lights	<ul style="list-style-type: none"> – Transmitter connected to the receiver plug at the KONTUR control unit 	<ul style="list-style-type: none"> – Change from receiver to the transmitter plug
LEDs at receiver will not light	<ul style="list-style-type: none"> – Connection cable to KONTUR control unit not plugged or defect – Supply voltage at the KONTUR control unit missing – Fuse on KONTUR control unit printed circuit board defective 	<ul style="list-style-type: none"> – Check connection and tight coupling ring. Check cable with Ohm meter (equal pin no.) – Check supply voltage at the plug-in connector – Open casing, check Si1 and replace if needed (microfuse T2A)
LEDs 2 and 3 of the receiver light constantly	<ul style="list-style-type: none"> – Transmitter and receiver are misaligned – DIP switch in KONTUR control unit not switched to the desired position – An object interrupts the sensing field constantly – Maximum distance of 3.5 m between transmitter and receiver exceeded 	<ul style="list-style-type: none"> – Cleaning, alignment (see Chapter 7) – Move DIP switch in in preferred position and disconnect and connect supply voltage (see Chapter 2.3) – Remove the object – Reduce distance between transmitter and receiver, clean front screens

Table 8-1 Troubleshooting and fault rectification (page 1 of 2)

Symptom	Possible Cause	Check/Remedy
LEDs 2 and 3 of the receiver light constantly	<ul style="list-style-type: none"> – Variable values in EPROM parameter field not correct for the selected application – Transmitter not connected 	<ul style="list-style-type: none"> – Check beam number of the connected optical parts according to the provided parameter table (see also Table 2-2). Compare identification number according to the provided parameter table (see Table 2-3) – Check connections and tight coupling rings – Measure cable with Ohm meter (equal pin numbers)
LEDs 2,3,4 and 5 (red) of the receiver light constantly	<ul style="list-style-type: none"> – Receiver connected to the KONTUR control unit's transmitter's plug KT.. 	<ul style="list-style-type: none"> – Unplug connecting cable and plug it to the receiver plug KR..
LEDs 4 and 5 (red) light constantly, LEDs 2 and 3 flicker at times	<ul style="list-style-type: none"> – Transmitter or receiver dirty – Transmitter and receiver are not adjusted correctly – Distance limit between transmitter and receiver reached 	<ul style="list-style-type: none"> – Clean transmitter and receiver – Adjust optical components (see Chapter 7) – Decrease distance between transmitter and receiver

Table 8-1 Troubleshooting and fault rectification (page 2 of 2)

The KONTUR control units contain self-diagnosis functions. A system check is made every time when the supply voltage is switched on.

Make sure, that both of the optical components KT and KR are connected before switching on the supply voltage to finish the system check successfully.

If a failure is recognized during system check, the receiver's LEDs 2,3 and 4,5 are blinking in a 2 Hz-rhythm.

9 Cleaning the Protecting Screens

Depending on environmental conditions the acrylic red screens should be cleaned at times with a soft piece of cloth moistened with pure alcohol.

10 After Sales Service

Our technical after-sales service offers the following services:

- Maintenance
- Training either at LUMIFLEX's or at customer's premises
- Fast delivery of spare parts and quick repairs

11 Appendix

11.1 Technical Data KONTUR Optical Units

Sensing field length	120 mm .. 3000 mm in steps of 120 mm
Sensing field width	3500 mm
Resolution	15 mm, 25 mm, 45 mm
Beam distance	10 mm, 20 mm, 40 mm
Max. Beam number	510
Time needed per beam	75 μ s (up to 255 beams)
	100 μ s (more than 255 beams)
Beam wafe length	900 nm
Transmitter:	Light-emitting diodes as defined by EN 60825-1:1994 + A1: 2002 + A2:2001
Class:	1
Wave length:	880 nm
Pulse duration:	5 μ s
Pulse pause:	450 ms
Output:	460 μ W
Modulation frequency	200 kHz
Sensing field status indication	Receiver's LEDs
Cable confusion indication	Transmitter's LED
Power supply	Delivered by KONTUR-TRIO or SOLO
Connector	Plug-connector type Binder 723-8-pin
Connecting cable	Cable 7-wires, shielded, max. 20 m
Housing	Extruded AL-casing
Protecting screen	Acrylic red
Enclosure rating	IP 65
Ambient operating temperature	0..55 °Celsius

Table 11-1 Technical data KONTUR optical components

11.2 Dimensional Drawing KONTUR Optical Units

Fig. 11-1 Dimensional drawing KONTUR optical units

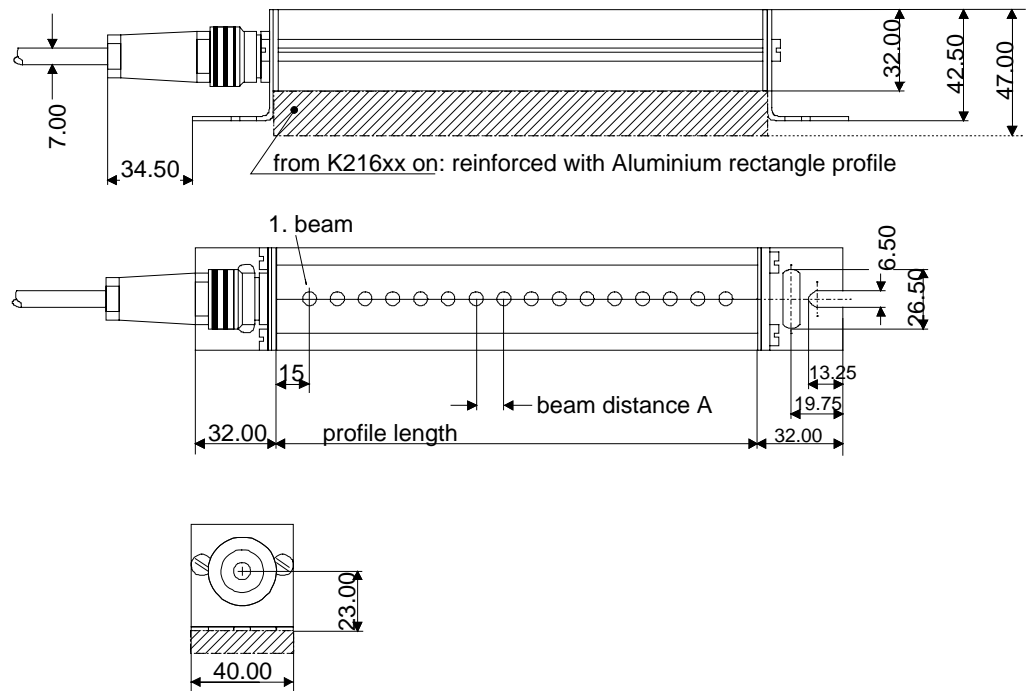

11.3 Dimension Table KONTUR Optical Units

The following table gives an overview about the available types of the KONTUR range.

KONTUR-type Sensor center distance A = 10 mm	KONTUR type Sensor center distance A = 20 mm	KONTUR type Sensor center distance A = 40 mm	Measuring zone length [mm]
K1210	K1220	K1240	120
K2410	K2420	K2440	240
K3610	K3620	K3640	360
K4810	K4820	K4840	480
K6010	K6020	K6040	600
K7210	K7220	K7240	720
K8410	K8420	K8440	840
K9610	K9620	K9640	960
K10810	K10820	K10840	1080
K12010	K12020	K12040	1200
K13210	K13220	K13240	1320
K14410	K14420	K14440	1440
K15610	K15620	K15640	1560
K16810	K16820	K16840	1680
K18010	K18020	K18040	1800
K19210	K19220	K19240	1920
K20410	K20420	K20440	2040
K21610	K21620	K21640	2160
K22810	K22820	K22840	2280
K24010	K24020	K24040	2400
K25210	K25220	K25240	2520
K26410	K26420	K26440	2640
K27610	K27620	K27640	2760
K28810	K28820	K28840	2280
K30010	K30020	K30040	3000

Table 11-2 Dimension Table KONTUR optical components

The optical units are described as follows:

Example: K22810

With the letter "K" and a sequence of digits the optical units, consisting of transmitter and receiver, are appointed. "K" stands for KONTUR, the sequence of digits indicates the approximate sensing field length and the beam distance. The designation K22810 describes a KONTUR with a sensing field length of about 2280 mm and a beam distance of 10 mm.

The transmitter is described with KT22810, the receiver with KR22810.

11.4 Technical Data KONTUR Control Units

Joint technical data for KONTUR-SOLO/p and KONTUR-TRIO and KONTUR-SOLO/XL:

Power supply	19 - 40 V DC, 1.7 A
Connections (optical components)	8-pin connectors
Housing	Al-casting
Rating	IP 65
Ambient operating temperature	0..55 °Celsius

KONTUR-SOLO/p only:

Light curtains to connect	One KONTUR with up to 510 beams
Modes of operation	Automatic scanning
Interface	13 bit opto-coupler output (open emitter) 1 bit opto-coupler input (open anode)
Connection (interface)	Plug-connector 16-pin with screw-type terminals

KONTUR-SOLO/XL only:

Light curtains to connect	One KONTUR with up to 510 beams
Modes of operation	Automatic and controlled scanning
Interface	21 bit opto-coupler output (open emitter) 1 bit opto-coupler input (open anode)
Connection (interface)	Plug-connector 24 pin with screw-type terminals

KONTUR-TRIO only:

Light curtains to connect	Max. three KONTUR: either - one KONTUR with up to 510 beams and two KONTURs with up to 63 beams each or - one KONTUR with up to 510 beams and one KONTUR with up to 255 beams or - one KONTUR with up to 510 beams
Modes of operation	Automatic or controlled scanning
Interface	21 bit opto-coupler output (open emitter) 1 bit opto-coupler input (open anode)
Connection (interface)	Plug-connector 24 pin with screw-type terminals

Table 11-3 Technical data KONTUR control units

11.5 Dimensional Drawing KONTUR-TRIO and KONTUR-SOLO/XL Control Units

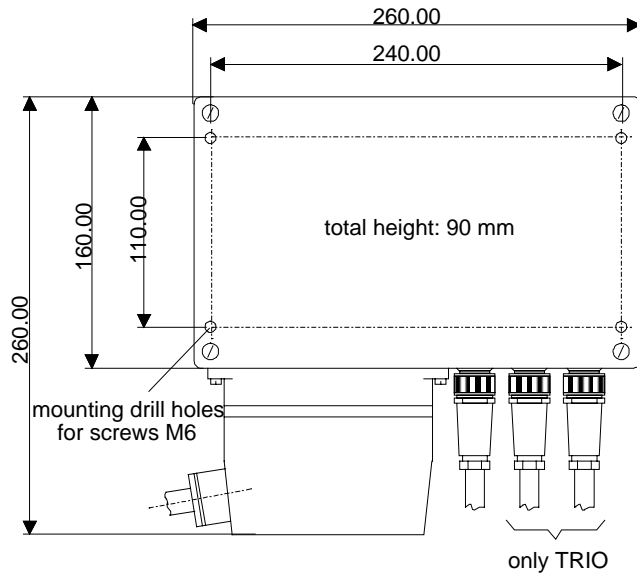

Fig. 11-2 Dimensional drawing KONTUR-TRIO and KONTUR-SOLO/XL control units

11.6 Dimensional Drawing KONTUR-SOLO/p Control Unit

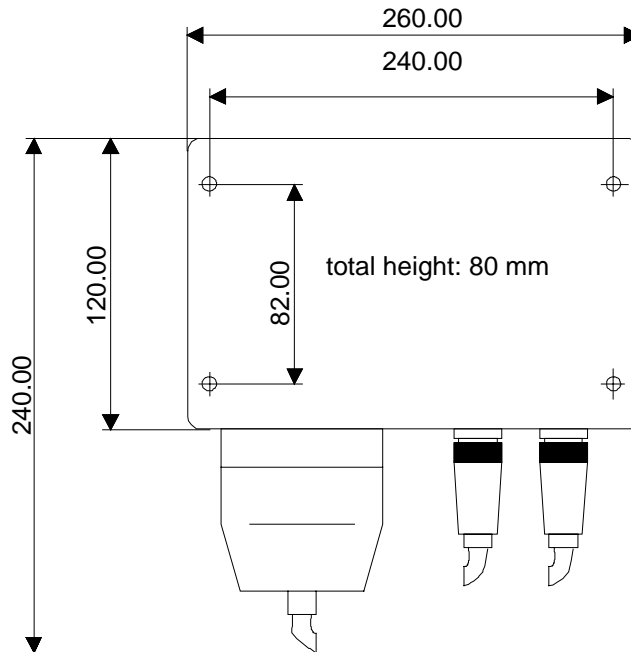

Fig. 11-3 Dimensional drawing KONTUR-SOLO/p control unit

12 Order Details and Scope of Supply

Details for optical units

- Quantity and type of light curtain(s)
- Part number
- Quantity and part numbers of connecting cables
 - Transmitter/control unit
 - Receiver/control unit

Details for control unit

- Quantity
- Type

Order example for a KONTUR measuring system, consisting of three optical components and a control unit:

- 1 KONTUR type K22810, part number 542281
- 2 connection cables KONTUR, length 10 m, part number 529110
- 1 KONTUR type K12020, part number 541202
- 2 connection cables KONTUR, length 5 m, part number 529105
- 1 KONTUR type K10840, part number 541083
- 2 connection cables KONTUR, length 2,5 m, part number 529102
- 1 control unit KONTUR-TRIO, part number 540020

The scope of supply consists of the above named components and of the Fitting and Operation Instructions.

13 EC Declaration of Conformity



Leuze lumiflex

EC Declaration of Conformity

according to EC Directive 89/336/EWG, Annex I

We herewith declare, Leuze lumiflex GmbH + Co. KG
Liebigstr. 4
D-82256 Fürstenfeldbruck, Germany

that the following described device complies with the appropriate EC Directive based on its design and type as brought into circulation by us. In case of alternations of the device, not agreed upon by us, this declaration will lose its validity.

Description of the component: **Measuring Light Curtain**
Component Type: **KONTUR and Control Units Solo/p, Solo/xl, Trio/p**
Serial number: see type plates
Applicable directives and standards: **EC Directive of Electromagnetic Compatibility (89/336/EEC) as amended by 91/263/EEC, 92/31/EEC and 93/68/EEC**
Employed standards: **EN 60204-1 : 1998**
 EN 60825-1: 1994+A1: 2002+A2:2001
CE-marking: **The compliance with the directive 89/336/EEC is certified by the CE-mark.**

Fürstenfeldbruck, January, 2006

ppa. Dr. Holger Lehmitz
Director product unit
Safety at work

ppa. Werner Lehner
Director product management



Leuze lumiflex GmbH + Co. KG
Liebigstraße 4
D - 82256 Fürstenfeldbruck
Telefon (08141) 5350 - 0
Telefax (08141) 5350 - 190
E-Mail: lumiflex@leuze.de
internet: http://www.leuze.de

Postbank München (BLZ 700 100 80)
 BIC: PBNKDEFF
Deutsche Bank (BLZ 700 700 10)
 Swift code: DEUTDEMM
UST-ID-Nr. DE 8134 60659
Steuer-Nr. 117/16/05708

Kto. 185 734 - 807
IBAN: DE 17 7001 0080 0185 7348 07
Kto. 1972 900
IBAN: DE 46 70070010 0 1972900 00
Finanzamt Fürstenfeldbruck

Kommanditgesellschaft, Sitz Fürstenfeldbruck
Amtsgericht München HRA 40417, pers. Haftende
Gesellschaft:
Leuze electronic, Geschäftsführungs-GmbH, Owen
Amtsgericht Kirchheim/Teck HRB 550
Geschäftsführer: Dr. Harald Gröbel, Michael Heyne