

SMART  
**SENSOR**  
BUSINESS

## SLS 78/R

Single Beam Safety Light Barrier



## Notes on Connecting and Operating Instructions



These connecting and operating instructions contain information on the proper use of SLS 78/R single beam safety devices in accordance with its intended purpose.

All the information contained herein, in particular the safety notes, need to be carefully observed.

Notes regarding safety and warnings are marked by this symbol .

Notes regarding important pieces of information are marked by the symbol .

These connecting and operating instructions must be stored carefully. It must be available for the entire operating time of the SLS 78/R.

**The Leuze electronic GmbH + Co. KG is not liable for damages caused by improper use. Acquaintance with these instructions is an element of the knowledge required for proper use.**

© Reprints and reproduction, in whole or in part, are permitted only with the explicit permission of

Leuze electronic GmbH + Co. KG

In der Braike 1

D-73277 Owen / Germany

Phone +49 (0) 7021 / 573-0

Fax +49 (0) 7021 / 573-199

info@leuze.de

www.leuze.com

<b>1</b>	<b>General</b> .....	<b>5</b>
1.1	Certifications .....	5
<b>2</b>	<b>Safety</b> .....	<b>6</b>
2.1	Approved purpose and foreseeable improper operation .....	6
2.1.1	Proper use.....	6
2.1.2	Foreseeable misuse .....	7
2.2	Competent personnel .....	8
2.3	Responsibility for safety .....	8
2.4	Exemption of liability .....	8
2.5	Operating mode .....	9
2.6	AOPD components for access guarding .....	9
2.7	Object size .....	9
<b>3</b>	<b>System design and possible uses</b> .....	<b>10</b>
3.1	Product features in overview.....	10
3.2	System design .....	10
3.3	Applications .....	10
<b>4</b>	<b>Display elements</b> .....	<b>11</b>
4.1	Transmitter .....	11
4.2	Receiver .....	11
<b>5</b>	<b>Installation</b> .....	<b>12</b>
5.1	General installation specifications .....	12
5.2	Safety distances.....	12
5.3	Response time .....	13
5.4	Protective field heights for SLS 78/R single beam safety devices for vertical access guarding 13	
5.5	Multiple beam setup .....	13
5.6	Radiation conditions .....	13
5.7	Distance to reflective surfaces.....	14
5.8	Deflecting mirror .....	15
5.9	Ranges with applications with deflecting mirror .....	16
<b>6</b>	<b>Electrical connection</b> .....	<b>17</b>
6.1	Relay contact spark suppression .....	17
6.2	Connection graphics.....	18
6.3	Examples for the safe integration of the SLS 78/R in the machine control .....	18
<b>7</b>	<b>Initial operation</b> .....	<b>19</b>
7.1	Alignment.....	20

- 8      Testing ..... 22**
- 8.1    Before the initial start-up and following modifications ..... 22
- 8.1.1   Checklist - before the initial start-up ..... 23
- 8.2    To be performed periodically by competent personnel ..... 24
- 8.3    To be performed daily by the operating personnel ..... 24
- 8.3.1   Check list - daily or at change of shift ..... 25
- 8.4    Cleaning the glass optics ..... 26
- 9      Faults and fault analysis/fault diagnostics..... 27**
- 10     Technical data ..... 28**
- 10.1   Safety-relevant technical data ..... 28
- 10.2   Transmitter and receiver ..... 29
- 10.3   Transmitter ..... 29
- 10.4   Receiver ..... 30
- 10.5   Plug connector ..... 30
- 10.6   Dimensional drawings ..... 31
- 11     Appendix..... 37**
- 11.1   Ordering information ..... 37
- 11.2   Accessories ..... 37
- 11.3   Checklist ..... 38
- 11.4   EC Declaration of Conformity ..... 40

## 1 General

The SLS 78/R Single Beam Safety Device is an a type 4 active opto-electronic protective device (AOPD) in accordance with EN IEC 61496-1, EN IEC 61496-2 and ISO 13849-1, and is equipped with two safety relays (positive-driven contacts). A protective field of infrared beams is generated between the transmitter and receiver of the safety light beam device. If this protective field is penetrated the guarded machine goes to a safe state before a person can be put in a dangerous situation.

The additional functions required for the access guarding in accordance with EN 61496-1, Annex A, can for example, be implemented with a safety-set machine control unit or with a safety sequential circuit (e.g. MSI-SR4).

Start/restart interlock and the monitoring of the output switching elements are integrated in the safety sequential circuit, as it is offered by Leuze electronic GmbH + Co. KG (e.g. MSI-SR4). It can issue the release or lock signal directly for the power-operated machinery.

### 1.1 Certifications

#### Company



**Leuze electronic GmbH + Co. KG in D-73277 Owen - Teck, Germany, has a certified quality assurance system in compliance with ISO 9001.**

#### Products



SLS 78/R single beam devices are developed and manufactured in compliance with applicable European directives and standards.

TÜV NORD CERT GmbH  
Certification center for product safety  
Named center: 0044  
Langemarckstr. 20  
45141 Essen

## 2 Safety

Before using the safety sensor, a risk evaluation must be performed according to valid standards (e.g. EN ISO 14121, EN ISO 12100-1, ISO 13849-1, IEC 61508, EN 62061). The result of the risk assessment determines the required safety level of the safety sensor (see Table 2.1-1.). For mounting, operating and testing, document "SLS 78/R Single Beam Safety Light Barrier" as well as all applicable national and international standards, regulations, rules and directives must be observed. Relevant and supplied documents must be observed, printed out and handed to the affected personnel.

Before working with the safety sensor, completely read and understand the documents applicable to your task.

In particular, the following national and international legal regulations apply for the start-up, technical inspections and work with safety sensors:

- Machinery directive 2006/42/EC
- Low voltage directive 2006/95/EC
- Electromagnetic compatibility directive 2004/108/EC
- Use of Work Equipment Directive
- Safety regulations
- Accident-prevention regulations and safety rules
- Ordinance on Industrial Safety and Health and Labor Protection Act
- Device Safety Act



### **Notice!**

*For safety-related information you may also contact the local authorities (e.g., industrial inspectorate, employer's liability insurance association, labor inspectorate, occupational safety and health authority).*

## 2.1 Approved purpose and foreseeable improper operation



### **Warning!**

A running machine can cause severe injuries!

*Make certain that, during all conversions, maintenance work and inspections, the system is securely shut down and protected against being restarted again.*

### 2.1.1 Proper use

- The safety sensor must only be used after it has been selected in accordance with the respectively applicable instructions and relevant standards, rules and regulations regarding labor protection and occupational safety, and after it has been installed on the machine, connected, commissioned, and checked by a competent person.
- When selecting the safety sensor it must be ensured that its safety-related capability meets or exceeds the required performance level PLr ascertained in the risk assessment.

The following table shows the safety-related characteristic parameters of the Single Light Beam Safety Device SLS 78/R.

Type in accordance with IEC/EN 61496	Type 4
Performance Level (PL) in accordance with ISO 13849-1: 2008	PL e
Category in accordance with ISO 13849-1	Cat. 4
Mean probability of a dangerous failure per hour (PFHd) as a function of the mean number of annual switching cycles of the relay $n_{op}^*$	$n_{op} = 4,800:$ $3.4 \times 10^{-8}$ 1/h $n_{op} = 28,800:$ $4.9 \times 10^{-8}$ 1/h $n_{op} = 86,400:$ $9.9 \times 10^{-8}$ 1/h
$*n_{op}$ = mean number of annual actuations, see C.4.2 and C.4.3 of ISO 13849-1: 2008 Use the following formula to calculate the mean number of annual actuations: $n_{op} = (d_{op} \cdot h_{op} \cdot 3600s/h) \div t_{Zyklus}$ In doing so, make the following assumptions with regard to the use of the component: $h_{op}$ = mean operating time in hours per day $d_{op}$ = mean operating time in days per year $t_{cycle}$ = mean time between the start of two successive cycles of the component (e.g. switching of a valve) in seconds per cycle	

**Tabelle 2.1-1:** Safety-related characteristic parameters of the Single Light Beam Safety Device SLS 78/R.

- The safety sensor protects persons at access points or at points of operation of machines and plants.
- The safety sensor detects persons only when they enter the danger zone but cannot tell whether there are any persons inside the danger zone. For this reason, a start/restart interlock is mandatory.
- The construction of the safety sensor must not be altered. When manipulating the safety sensor, the protective function is no longer guaranteed. Manipulating the safety sensor also voids all warranty claims against the manufacturer of the safety sensor.
- The safety sensor must be tested regularly by competent personnel.
- The safety sensor must be exchanged after a maximum of 20 years. Repairs or the exchange of parts subject to wear and tear do not extend the service life.
- Additional measures must be taken to ensure that the ESPE does not experience a dangerous failure due to glare from other light sources.

### 2.1.2 Foreseeable misuse

In principle, the safety sensor is not suitable as a protective device in case of:

- danger of objects being expelled or hot or dangerous liquids spurting from the danger zone
- applications in explosive or easily flammable atmospheres
- reachability of the point of operation by hand from the mounting location of the safety sensor
- detection of the presence of persons in danger areas

- Optical influence on the ESPE through other forms of light beams:  
e.g.
- wireless control devices on cranes
- radiation from welding sparks
- strobe lights

## **2.2 Competent personnel**

Prerequisites for competent personnel:

- has a suitable technical education
- he knows the rules and regulations for occupational safety, safety at work and safety technology and can assess the safety of the machine
- he knows the instructions for the safety sensor and the machine
- has been instructed by the responsible person on the mounting and operation of the machine and of the safety sensor

## **2.3 Responsibility for safety**

Manufacturer and operating company must ensure that the machine and implemented safety sensor function properly and that all affected persons are adequately informed and trained.

The type and content of all imparted information must not lead to unsafe actions by users.

The manufacturer of the machine is responsible for:

- safe machine construction
- safe implementation of the safety sensor
- imparting all relevant information to the operating company
- adhering to all regulations and directives for the safe starting-up of the machine

The operator of the machine is responsible for:

- instructing the operating personnel
- maintaining the safe operation of the machine
- adhering to all regulations and directives for occupational safety and safety at work
- regular testing by competent personnel

## **2.4 Exemption of liability**

Leuze electronic GmbH + Co. KG is not liable in the following cases:

- safety sensor is not used as intended
- safety notices are not adhered to
- reasonably foreseeable misuse is not taken into account
- mounting and electrical connection are not properly performed
- proper function is not tested
- changes (e.g., constructional) are made to the safety sensor



## 2.5 Operating mode

The SLS 78/R works in the "Protective mode without restart interlock" operating mode. With a connection between terminals 3 and 4 the transmitter sends pulsed infrared light. With reception of the light beam the OSSD outputs of the receiver switch on. With interruption the contacts open within the system response time. As soon as the light beam is free again the OSSDs turn on again automatically.

Important additional functions such as restart interlock, contactor monitoring or muting can be implemented with MSI series safety sequential circuits.

## 2.6 AOPD components for access guarding

For these purposes the active opto-electronic protective device (AOPD) consists of the single light beam safety device (transmitter and receiver), the deflecting mirrors and the safety sequential circuit with start/restart interlock. All elements of this system must be coordinated with one another to guarantee safe operation.

It applies for the SLS 78/R that people are only detected during the access; their presence in the danger zone, however, is not detected! If a person interrupts the light beam or if there is an AOPD fault, the safety sequential circuit must therefore go into safe interlock.

The start/restart interlock may only be unlocked via a start/restart button, which must be installed so that the danger area can completely be seen from its installation point. It must be impossible to reach the button from the danger area.



### **Note!**

*A harmonized safety system in accordance with the requirements of safety category 4 is achieved when, for example, the safety sequential circuits MSI-SR2 or MSI-SR2/F (accessories provided by Leuze electronic GmbH + Co. KG) are used, or the sequential circuit is set up in accordance with the circuitry example (see chapter 6.3).*

## 2.7 Object size

The SLS 78/R is suitable for detecting objects with a minimum diameter of 30 mm.

## 3 System design and possible uses

### 3.1 Product features in overview

- Relay outputs with positive-guided safety contacts
- Easy connection with transparent terminal area
- Plug accessories in acc. with DIN 43651
- Glass optics with spacing bolts for mounting laser alignment aid
- Integrated optics heating for use with extreme ambient conditions
- Compact aluminum housing
- Safe integration in the control system with MSI series safety interfaces

### 3.2 System design

The SLS 78/R consists of a transmitter (SLS 78/2 SE-24 V) and a receiver SLS 78/RE-24 V). With free light path between transmitter and receiver the receiver switches on. The system is set to the frequency of the light pulses. Constant light or other light pulses are not evaluated. The device is configured for use in harsh environmental conditions. With the cable connection the requirements of protection rating IP 65 are met; the SLS 78/R is therefore dust-proof and water-protected. An integrated optics heating prevents the optics from fogging up on the inside (within specifications).

The system is designed for distances from 0 to 60 m. Errors in the system are detected within the response time (20 ms) and cause the dangerous movement to switch off.

Transmitter and receiver of the light beam device work with a supply voltage of 24 V DC.

### 3.3 Applications

Active opto-electronic protective devices with safety sequential circuits are suitable, for example, for the following areas of application:

- Processing machinery in the metals industry
- Setting machines in the glass and ceramics industry
- Robot application areas
- Automated stacking systems/packaging machinery, etc.
- Storage installations and equipment
- Print and paper processing machinery
- Plastics and rubbers industry
- Wood processing industry machinery



#### **Warning!**

*The SLS 78/R may never be used as the sole arm, hand or finger protection (e.g. on metal-processing presses).*

## 4 Display elements

The LED display elements provide quick information on the operating status of the transmitter and the receiver.

### 4.1 Transmitter

LED 1 (green): Transmitter is switched active when LED lights

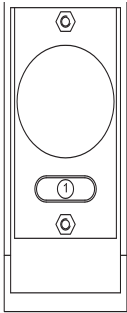

**Bild 4.1-1:** Transmitter LED display

### 4.2 Receiver

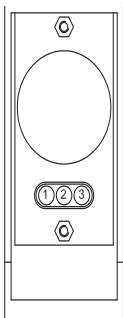

**Bild 4.2-1:** Receiver LED displays

Red (1)	Yellow (2)	Green (3)	Description
On	Off	Off	Protective field not free
On	Flashing	Off	Protective field not free; reception level too low
Off	Flashing	On	Protective field free; no function reserve
Off	Off	On	Protective field free; function reserve available
On	On	Off	Fault

## 5 Installation

### 5.1 General installation specifications

The general safety precautions in chapter 2 must be observed.  
 The devices must basically be installed in such a way that the danger area can only be reached by interrupting the beams and a sufficient safety distance between danger area and protective field is ensured.  
 The dimension details required for the installation are provided in chapter 10.6.

### 5.2 Safety distances

The light beam safety device must be mounted at a great enough distance from the dangerous movement. With an interruption of the light beam it must only be possible to reach the danger area when the machine has already stopped its movement.

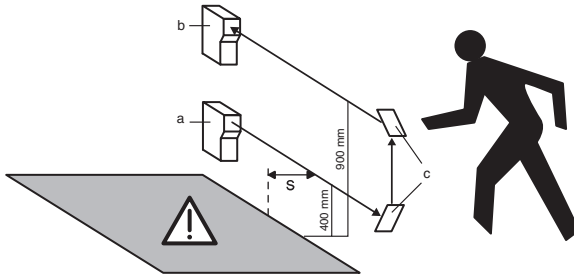

**Bild 5.2-1:** Safety distances

The safety distance “S” between light beam device and danger area is calculated with the following formula:

$$S = (K \cdot T) + C \text{ (in acc. with EN 999)}$$

S: Safety distance between light beam device and danger area (mm)

K: Approach speed (constant 1600 mm/s)

T: Delay time between beam interruption and the machine's motionless state (s)

C: Safety constant = 850 mm

An example:

The beam heights of a light beam device are 400 mm and 900 mm.

The approach speed (T) is set to 1600 mm/s,

the delay time is 0.2 s.

$$S = 1600 \text{ mm/s} \cdot 0.2 \text{ s} + 850 \text{ mm}$$

$$S = 1170 \text{ mm}$$

The safety distance must therefore be at least 1170 mm.

**5.3 Response time**

The SLS 78/R response time is 20 ms.

**5.4 Protective field heights for SLS 78/R single beam safety devices for vertical access guarding**

With the installation of SLS 78/R single beam safety devices as access or area guarding, danger areas must not be accessible by crawling under, stepping over or reaching over the light beams. The number of beams and their distances depend on the risk assessment and the specifications of the individual machine.

EN 999 recommends the following guarding levels:

Number of beams	Height above reference plane, e.g. floor in mm
4	300, 600, 900, 1200
3	300, 700, 1100
2	400, 900

**Tabelle 5.4-1:** Guarding heights

**5.5 Multiple beam setup**

a = Transmitter  
 b = Receiver  
 c = Deflecting mirror

With multiple beam setups the light beams must be parallel to the reference level (e.g. floor) and aligned parallel with one another. Each beam direction must be provided inversely here. Otherwise the light beams could influence each other and impair the safety function. Please observe chapter 5.6.

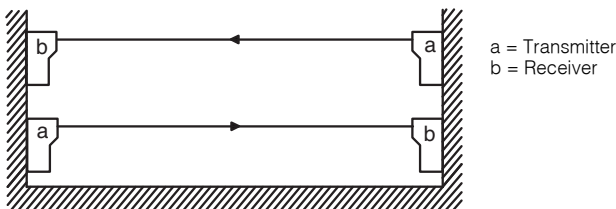

**Bild 5.5-1:** Multiple beam setup

**5.6 Radiation conditions**

The SLS 78/R transmitter and receiver have a maximum permissible light beam radiation angle of  $\pm 2^\circ$  to the optical axis (with protective field widths of more than 3 m).



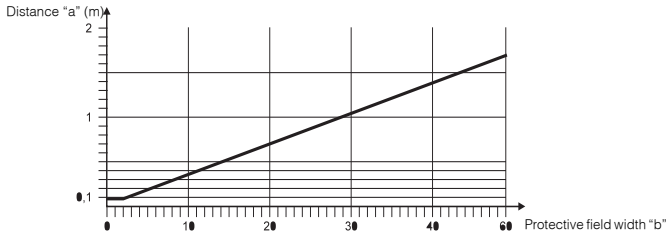

**Bild 5.7-3:** Minimum distance of the multiple light beam safety device from reflective surfaces

### 5.8 Deflecting mirror

A series of important factors must be taken into account with use of deflecting mirrors:

- A range loss occurs with all light beam deflections with deflecting mirrors.
- A dirty deflection mirror must always be prevented.
- The environmental conditions must taken into account, as vapors and dusty air also considerably restrict the range.
- The distances between transmitter and deflecting mirror and between receiver and deflecting mirror must not be less than 0.5 m.

Examples for applications with deflecting mirrors:

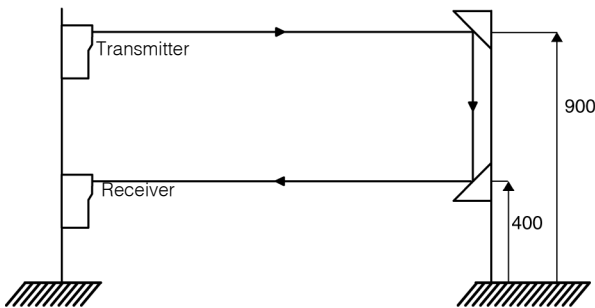

**Bild 5.8-1:** Example 1 for applications with deflecting mirror, side view

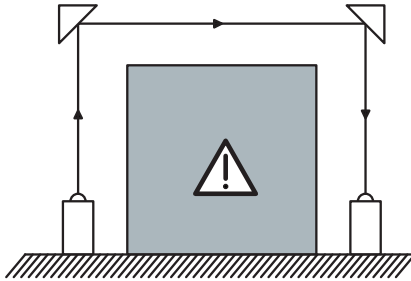

**Bild 5.8-2:** Example 2 for applications with deflecting mirror, top view

### 5.9 Ranges with applications with deflecting mirror

Configuration	Maximum range with 0.85 range factor
SLS 78/R without deflecting mirror	60 m
SLS 78/R with 1 deflecting mirror	51 m
SLS 78/R with 2 deflecting mirror	43 m

**Tabelle 5.9-1:** Ranges with applications with deflecting mirror



## 6 Electrical connection

- Installation and wiring of the SLS78 /R is to be performed in accordance with applicable standards and safety regulations, particularly when connecting dangerous switching voltages.
- The electrical connection must be performed by experienced personnel. Knowledge of all safety notes contained in these operating instructions is part of this competence.
- The external supply voltage of 24 V DC +/- 20% must guarantee safe isolation from the mains voltage in accordance with IEC 60742 and be able to bridge a power outage period of at least 20 ms. Leuze electronic GmbH + Co. KG offers suitable power supplies (see list of accessories in the Appendix chapter 11.2). The power supply selected must not supply any other parts of the machine with power other than the safety components connected. Transmitters and receivers must be supplied from a shared power supply and must be fused against overcurrent.
- Basically both safety related switching outputs OSSD1 and OSSD2 must be looped into the work circuit of the machine.
- The start/restart button for unlocking the restart interlock must be mounted in such a way that it cannot be reached from the danger area and the entire danger area is fully visible from its installation position.
- It is vital during the electrical installation that the power of the machine or system to be secured is switched off locked, so that the dangerous movements cannot be started up again unintentionally.

### Connection system

**Warning:**

*The housing cover must be screwed off before the electrical connection. Before opening the cover, the SLS78/R must be disconnected from power. Where required the cover contact (yellow/green cable) must be removed and replaced again before re-mounting the cover.*

The PG cable glands are suitable for cables with a diameter of 7 to 10 mm. The minimum conductor cross-section is 0.25 mm<sup>2</sup>.

**Warning:**

*The PG cable glands and the housing cover must be properly screwed tight so that the specified IP 65 protection rating for the housing is guaranteed.*

The union nut must be screwed tight with the plug configuration (in acc. with DIN 43651). The sequence control must be connected with the relay outputs in accordance with the connection graphics. According to the applicable regulations for type 4 AOPDs both make contacts must be used for the safe switch-off of the technical device.

The contacts must be protected with a fuse (3 AmT).



**Notice!**  
*Laying cables!*

- Lay all connection cables and signal lines within the electrical installation space or permanently in cable ducts.
- Lay the cables and lines so that they are protected against external damages.
- For further information: see EN ISO 13849-2, Table D.4.

**6.1 Relay contact spark suppression**

Suitable spark extinction elements (e.g. RC modules, varistors or recovery diodes) are mandatory with switching inductive loads such as contactors and relays. They must be switched parallel for inductance.

These extend the delay times of inductive switching elements.

**6.2 Connection graphics**

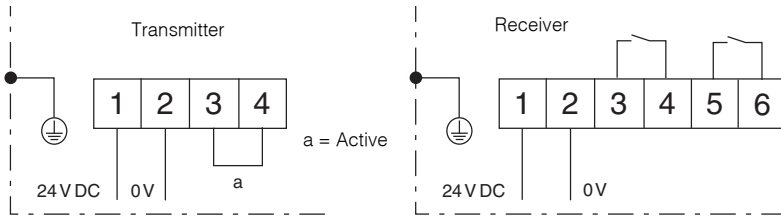

**Bild 6.2-1:** Terminal version connection

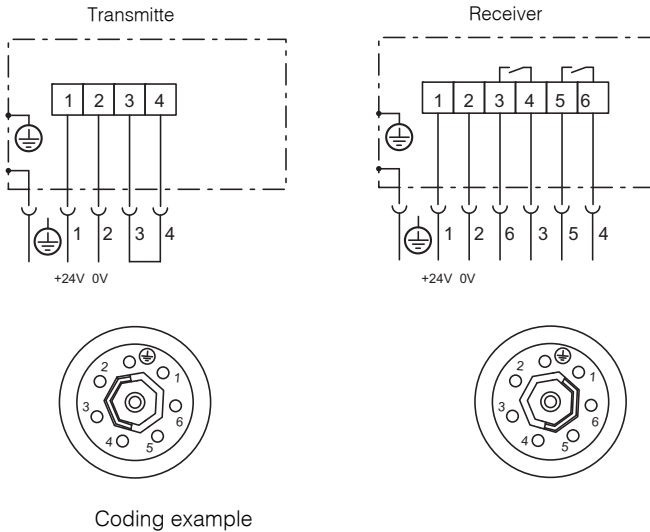

**Bild 6.2-2:** Plug version AS78-01/AS78-02 connection

### 6.3 Examples for the safe integration of the SLS 78/R in the machine control

Various SLS 78/R connection options are possible. If the safety-related control system of the machine has the interlocking and monitoring functions required for the integration, such as "Start/restart interlock" and "Contactor monitoring", then the direct connection of the single beam safety device to the control system is possible. The functions are performed by the MSI-SR4 in the following example.

## 7 Initial operation

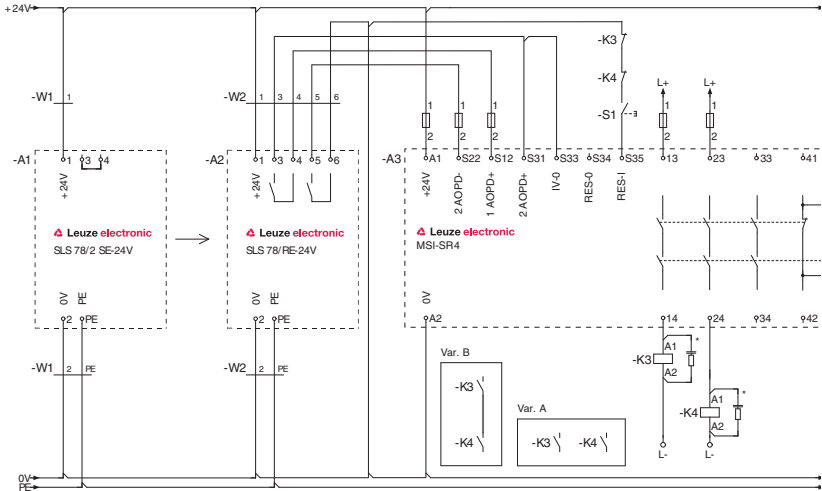

**Bild 7.0-1:** Example: SLS 78/R with MSI-SR4



### Warning:

Before putting the SLS 78/R into operation for the first time on a power-driven production machine, an experienced and commissioned person with suitable training must check the entire setup and the integration of the opto-electronic protective device into the machine control system.

Before connecting the supply voltage for the first time and while the transmitters and receivers are being aligned, it must also be ensured that the outputs of the optical safety device do not have any effect on the machine. The switching elements that finally set the dangerous machine in motion must be safely switched off and secured from restarting.

The same precautionary measures apply after every change made to the optical protective device, e.g. after repairs or during maintenance work, after an alignment or after longer stopped periods.

Only after it has been determined that the opto-electronic protective device functions correctly and without fault, including the safety sequential circuit, can it be integrated into the machine's control circuit!

## 7.1 Alignment

1. After the installation the optical axis of the transmitter and the receiver should be identical (see chapter 5).
2. Jumper the connection 3-4 on the transmitter for aligning the SLS 78/R.
3. Check the electrical connections before switching on the light beam device.
4. Check the LED on the transmitter.

If the LED on the transmitter lights green, connection 3-4 is switched and the transmitter is active.

5. Check the alignment state of the receiver shown by the LEDs. You will find a list of the individual states in chapter 4.2.
6. If the receiver is ready for operation go to Chapter 8.4.
7. If only the red LED lights on the receiver this means that the supply voltage is present but no transmitter light is received or an object is blanking out the light beam – the protective field is not free. In this case you must perform steps 6 to 9.
8. Loosen the fixing of the transmitter and receiver and find the optical center point by moving up, down and across and precisely observing the receiver's LEDs (see chapter 5).

The alignment is made very easy with use of the LA78 laser alignment aid (order no. 549000) and the corresponding fixing components from Leuze electronic GmbH + Co. KG.

Two studs for fixing the laser alignment aid are attached for this with the transmitter and receiver, on the optics side in each case. After screwing off the alignment aid, the alignment of the light beam devices is changed until the light point generated by the LA78 hits the optic of the opposing device (rec. or trans.). A check must be made in the reverse beam direction so that an optimum alignment is achieved.

9. If reflective components are in the area of the light beam, this must be taken into account with the alignment. The transmitter and receiver must be aligned in a way that ensures that there are no reflective components in the area of the effective beam angle. For this, see also the diagram with minimum distances in chapter 5.7.
10. After the alignment has been completed the SLS 78/R must be fixed again.
11. After the alignment and initial operation work has been completed the proper functioning is checked using an object of at least 30 mm diameter at every point of the beam path between the transmitter and the receiver. The receiver's output relay must drop out every time (see chapter 4.2).

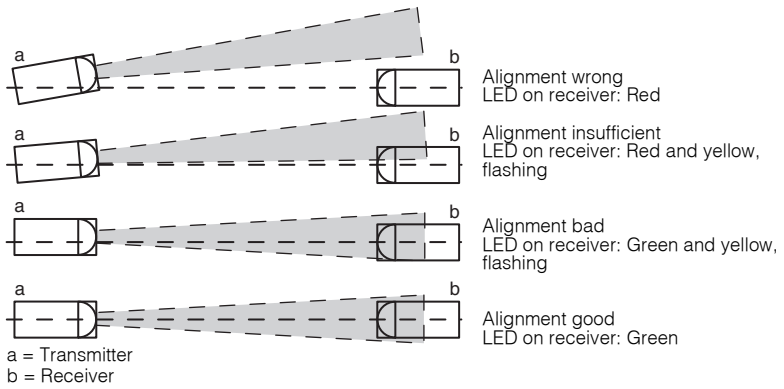

**Bild 7.1-1:** Optical alignment check

## 8 Testing



### **Warning!**

*A running machine can cause severe injuries!  
Make certain that, during all conversions, maintenance work and inspections, the system is securely shut down and protected against being restarted again.*

The safety sensors must be exchanged after a maximum of 20 years.

- Always exchange entire safety sensors.
- For the tests, observe nationally applicable regulations.
- Document all tests in a comprehensible manner.

### 8.1 Before the initial start-up and following modifications

Acc. to IEC TS62046 and national regulations (e.g. EU directive 89/655 EEC), tests are to be performed by competent personnel in the following situations:

- Prior to the initial start-up
- Following modifications to the machine
- After longer machine downtime
- Following retrofitting or reconfiguration of the safety sensor



### **Warning!**

*Unforeseeable behavior of the machine during the initial commissioning can lead to severe injuries!  
Make certain that there are no persons in the danger zone.*

- Test the effectiveness of the shut-down function in all operating modes of the machine acc. to the following checklist.
- Document all tests in a comprehensible manner and include the configuration of the safety sensor along with the data for the safety- and minimum distances in the documentation.
- Before they begin work, train the operating personnel on their respective tasks. The training is the responsibility of the operating company.
- Attach notices regarding daily testing in the respective national language of the operating personnel on the machine in a highly visible location, e.g. by printing out the corresponding chapter (see chapter 8.3).
- Check whether the safety sensor was correctly selected acc. to the locally applicable regulations and directives.
- Check whether the safety sensor is operated acc. to the specified environmental conditions.
- Make certain that the safety sensor is protected against overcurrent.
- Perform a visual inspection for damage and test the electrical function.

Minimum requirements for the power supply unit:

- Safe mains separation
- At least 2 A current reserve
- Power-failure bridging for at least 20 ms

Not until proper function of the optoelectronic safety device is ascertained may it be integrated in the control circuit of the system.



**Notice!**

*As a safety inspection, Leuze electronic offers testing by a competent person prior to the initial start-up .*

**8.1.1 Checklist - before the initial start-up**

Tester: competent person

This checklist serves as a reference for the machine manufacturer or supplier. It replaces neither testing of the complete machine or system prior to the initial start-up nor their periodic testing by a competent person. This checklist contains minimum testing requirements. Depending on the application, other tests may be necessary.

- Store this checklist with the machine documents.

Check:	Yes	No
Were all safety directives and standards relevant to this machine type observed?		
Does the Declaration of Conformity of the machine include a listing of these documents?		
Does the safety sensor satisfy the safety-related capability (PL, SIL, category) as required by the risk assessment?		
Circuit diagram: Are both safety-related switching outputs (OSSDs) integrated in the downstream machine control acc. To the required safety category?		
Circuit diagram: Are the switching elements (e.g. contactors) with positive-guided contacts that are controlled by the safety sensor monitored by a feedback circuit (EDM)?		
Does the electrical wiring match the circuit diagrams?		
Have the required protective measures against electrical shock been effectively implemented?		
Has the maximum stopping time of the machine been remeasured and recorded in the machine documents?		
Is the required safety distance (protective field of the safety sensor to the next point of operation) maintained?		
Are all points of operation of the machine accessible only through the protective field of the safety sensor? Are all additional protective devices (e.g. safety guards) correctly mounted and protected against tampering?		
Is the command device for triggering the start/restart interlock of the safety sensor or the machine mounted in accordance with specifications?		
Is the safety sensor correctly aligned and are all fastening screws and plugs secure?		



<b>Check:</b>	<b>Yes</b>	<b>No</b>
Are safety sensor, connecting cable, plug, protection caps and command devices undamaged and without any sign of manipulation?		
Has the effectiveness of the protective function been checked for all operating modes of the machine by means of a function test?		
Is the start-/restart button for resetting the AOPD mounted outside of the danger zone in accordance with specifications in such a way that it cannot be reached from within the danger zone? Can the entire danger zone be seen from the place at which the start-/restart button is installed?		
Does the interruption of any given beam cause the dangerous movement to stop?		
When the AOPD is separated from its supply voltage, does the dangerous movement stop, and, after the supply voltage has been restored, is it necessary to actuate the start-/restart button to reset the machine?		
Is the safety sensor effective during the entire dangerous movement of the machine?		
Is the dangerous movement stopped upon changing the operating mode of the machine or while switching to another protective device?		
Are the notices for daily testing of the safety sensor legible to the operating personnel and are they located in a highly visible location?		

**Tabelle 8.1-1:** Checklist - before the initial start-up

## 8.2 To be performed periodically by competent personnel

The reliable interaction of safety sensor and machine must be periodically tested in order to detect changes to

the machine or impermissible tampering with the safety sensor. Testing intervals are determined by nationally applicable regulations (recommendation acc. to IEC TS62046: 6 months).

- Have all tests performed by competent personnel.
- Observe the nationally applicable regulations and the time periods specified therein.



**Notice!**

*As a safety inspection, Leuze electronic offers periodic testing by a competent person.*

### 8.3 To be performed daily by the operating personnel

The function of the safety sensor must be checked daily, at change of shifts, and at each change of machine operating mode as specified in the following check list so that damage or unauthorized manipulation can be detected.



**Warning!**

*Unforeseeable behavior of the machine during the check can lead to severe injuries! Make certain that there are no persons in the danger zone.*

**Warning!**

*If the daily check is carried out incorrectly, further operation of the machine can lead to severe injuries!*

*If you answer one of the items on the check list (see Table 8.3-1) with no, the machine must no longer be operated.*

*Have the entire machine inspected by a competent person (see Chapter 8.1.).*

- Stop the dangerous state.
- Check transmitter, receiver and, if applicable, deflecting mirrors for damage or manipulation.
- Interrupt the light beam from a position outside the danger zone and ensure that the machine cannot be started with an interrupted light beam.
- Start the machine.
- Ensure that the dangerous state is stopped as soon as a light beam is interrupted.

#### 8.3.1 Check list - daily or at change of shift

Tester: Authorized operating personnel or instructed person

Check:	Yes	No
Is the safety sensor aligned correctly? Are all fastening screws tightened and all connectors secured?		
Are safety sensor, connecting cable, plug and command devices undamaged and without any sign of manipulation?		
Are all points of operation of the machine accessible only through the protective field of the safety sensor?		
Are all additional protective devices mounted correctly (e.g., safety guard)?		
Does the start/restart interlock prevent the automatic start-up of the machine after the safety sensor has been switched on or activated?		
Interrupt a light axis of the safety sensor with a test object during operation. Is the dangerous movement shut down immediately?		

**Tabelle 8.3-1:** Check list - daily or at change of shift

## **8.4 Cleaning the glass optics**

The glass optics on the transmitters and receivers must be cleaned regularly depending on how dirty they are. A flashing LED display of the receiver with free protective field (LED2 is yellow) indicates a "weak reception signal"; cleaning is then required. If cleaning the screens does not improve this, then the detection range and alignment must be checked. We recommend using a mild cleanser for cleaning the glass optics. The screens are resistant to thinned acids or alkalis and resistant to organic solvents within limits.

**9 Faults and fault analysis/fault diagnostics**

Fault	Possible causes	Test and fault removal
LED does not light in transmitter or receiver	Supply voltage not present  Short circuit in the receiver	Turn on main switch on the machine; check fuse in feed line  Turn off main switch and wait 10 sec. until the electronic fuse in the receiver switches on again
LED in transmitter does not light	Supply voltage on transmitter not present; connection cable defective  Short circuit in the transmitter  Transmitter activation (jumper 3-4) interrupted	Check supply voltage on the connection terminals  Switch off main switch and wait 10 sec. until the electronic fuse in the transmitter switches on again  Check circuit
LED in transmitter lights; LEDs in the receiver do not light	Supply voltage on receiver not present; connection cable defective  Short circuit in the receiver  Interruption on relay contact; relay defective; transmitter defective	Check supply voltage on the connection terminals  Turn off main switch and wait 10 sec. until the electronic fuse in the receiver switches on again  Send device in for repair
Red LED in receiver lights; no light reception	Devices or deflecting mirror misaligned  Optics or deflecting mirror dirty  Jumper 3-4 in transmitter interrupted  Receiver defective	Realign devices or deflecting mirror  Clean optics/deflecting mirror  Check activation  Send device in for repair
Red LED in receiver lights; yellow LED in receiver flashes	Devices or deflecting mirror misaligned  Optics or deflecting mirror dirty	Realign devices or deflecting mirror  Clean optics/deflecting mirror
Red and yellow LED in receiver light constantly	Electronic monitoring circuit of the receiver has responded; cause is, e.g. the reciprocal influence of two SLS 78/R pairs  Receiver defective	Switch supply voltage on receiver on and off (at least 2 sec.); Check beam path of the sensors  Send device in for repair

## 10 Technical data

### 10.1 Safety-relevant technical data

Type in accordance with IEC/EN 61496	Type 4
Performance Level (PL) in accordance with ISO 13849-1: 2008	PL e
Category in accordance with ISO 13849-1	Cat. 4
Mean probability of a dangerous failure per hour (PFHd) as a function of the mean number of annual switching cycles of the relay $n_{op}^*$	$n_{op} = 4,800: 3.4 \times 10^{-8} \text{ 1/h}$ $n_{op} = 28,800: 4.9 \times 10^{-8} \text{ 1/h}$ $n_{op} = 86,400: 9.9 \times 10^{-8} \text{ 1/h}$
Number of cycles until 10 % of the components have a failure to danger ( $B_{10d}$ )	400,000 switching cycles at rated load 20 million switching cycles at 20% of rated load
Service life ( $T_M$ )	20 years**
<p>*<math>n_{op}</math> = mean number of annual actuations, see C.4.2 and C.4.3 of ISO 13849-1: 2008</p> <p>** The date of manufacture can be found on the name plate and is included in the serial number (YY/WW):                  2nd and 3rd digits: JJ year of construction                  4th and 5th digits: WW calendar week</p> <p>Use the following formula to calculate the mean number of annual actuations:</p> $n_{op} = (d_{op} \cdot h_{op} \cdot 3600\text{s/h}) \div t_{Zyklus}$ <p>In doing so, make the following assumptions with regard to the use of the component:  <math>h_{op}</math> = mean operating time in hours per day  <math>d_{op}</math> = mean operating time in days per year  <math>t_{cycle}</math> = mean time between the start of two successive cycles of the component (e.g switching of a valve) in seconds per cycle</p>	

**10.2 Transmitter and receiver**

Protection rating (devices with cable connection)	IP 65
Supply voltage	24 V DC, ± 15 %, external power supply with secure supply line isolation and equalization with a 20 ms loss in voltage required
Residual ripple	≤ 10 %
Optics	Glass, 30 mm Ø
Optics heating	Integrated
Operating temperature	-25°C to +60°C
Storage temperature	-25°C to +70°C
Relative humidity (not condens.)	95 %
Shock and vibration stability	In acc. with DIN VDE 0113, Part 201, Part 1 (gen. requirements)
Housing	Aluminum diecast
Color/paint	Yellow, RAL 1006 Lead and cadmium-free
Housing/insulation class	Safety class I
Cable routing	PG 11 cable, Ø 7-10 mm
Installation point	Any
Fixing/installation	M6 threaded holes (see dim. drawings)
Year of construction	2010

**Tabelle 10.2-1:** Mechanical data for transmitter and receiver

**10.3 Transmitter**

Current consumption	Typical 100 mA
Optical transmitter	GaA/As diode
Wavelength	880 nm
Effective beam angle	From 3 m ≤ +/- 2°
LED display	Green, with active transmitter
SLS 78/2 SE-24 V weight	580 g
Fine-wire fuse, internal	125 mA melting fuse

**Tabelle 10.3-1:** Technical data, transmitter

## 10.4 Receiver

Current consumption	Typical 250 mA
Response time	≤20 ms
Switching	Light switching
Outputs	Relay, 2S, positive-guided
Maximum switching voltage	250 V AC (Overvoltage category II)
Maximum switching currents	2 A, AC-1/DC-1
Fuse protection per output contact:	3AmT
LED display	Green, yellow, red (switching sequence, see chapter 4.2)
Effective light reception angle	From 3 m ≤ ± 2°
Ambient light sensitivity	In acc. with DIN VDE 0113, active opto-sensors
Detection range	0 to 60 m
Maximum cable length	100 m with 0.25 mm <sup>2</sup>
SLS 78/RE-24 V weight	600 g
Fine-wire fuse	0.5 A melting fuse

**Tabelle 10.4-1:** Technical data, receiver

## 10.5 Plug connector

Connector plug	In acc. with DIN 43651, encoded (see chapter 6.2)
Protection rating	IP 65
Cable socket (straight)	For cable 6-9 mm Ø, included with delivery

**Tabelle 10.5-1:** Plug connector mechanical data

### 10.6 Dimensional drawings

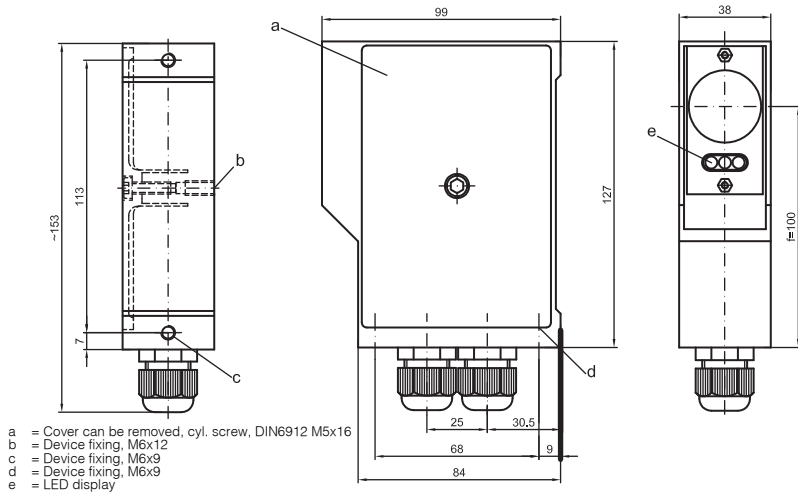

**Bild 10.6-1:** SLS 78/R with PG cable gland



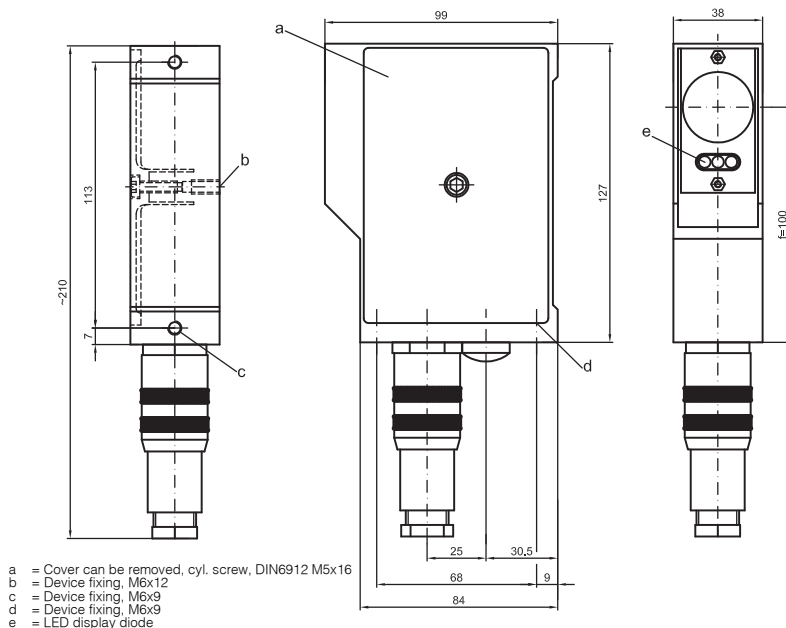

**Bild 10.6-2:** SLS 78/R with plug connection in acc. with DIN 43651

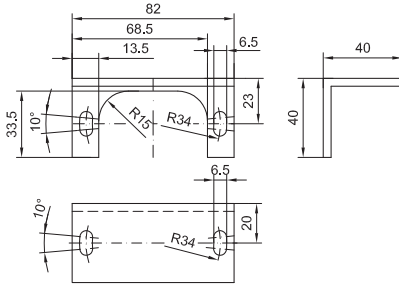

**Bild 10.6-3:** BT78 mounting angle

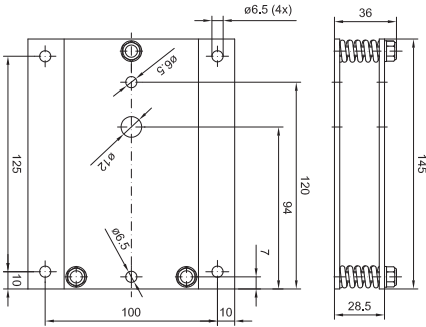

**Bild 10.6-4:** BT16 mounting plate with SLS alignment

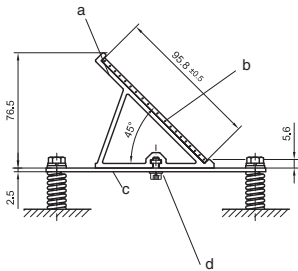

- a = Mirror carrier can rotate by 90° on plate
- b = Mirror (95.8x79)
- c = Plate
- d = Screw, DIN912-M4x10 (2x)  
+ spring lock washer DIN127-A4 (2x)
- e = Mirror center
- f = Mirror carrier rotated by 90°

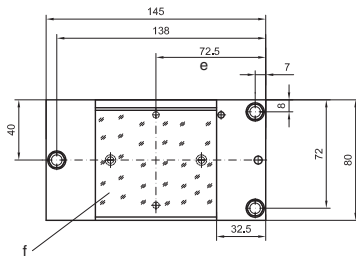

**Bild 10.6-5:** US2 deflecting mirror

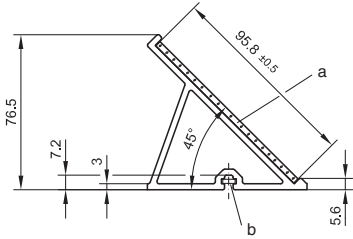

- a = Mirror (95.8x79)
- b = 2 sliding nuts, M4

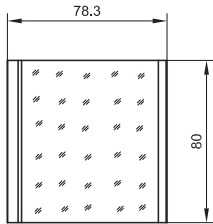

**Bild 10.6-6:** US2.1 deflecting mirror graphics

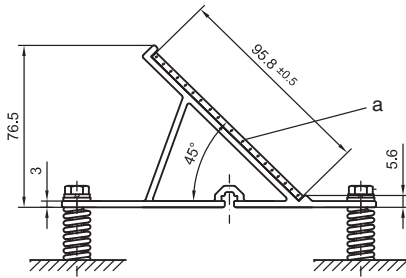

a = Mirror (95.8x79)

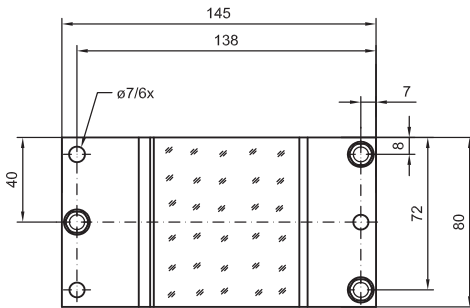

**Bild 10.6-7:** US2.2 deflecting mirror graphics

## 11 Appendix

### 11.1 Ordering information

Light beam safety device (transmitter and receiver)	SLS 78/R	Order no.
Transmitter	SLS 78/2 SE-24 V	50021208
Receiver	SLS 78/RE-24 V	50021209
If the safety light beam device is required with plug connection, plug sets are available for transmitter and receiver separately (see chapter 11.2).		

**Tabelle 11.1-1:** Ordering information for SLS 78/R Single Beam Safety Device

### 11.2 Accessories

Plug set for transmitter	AS 78-01	50021778
Plug set for receiver	AS 78-02	50021779
Laser alignment aid for SLS single beam safety devices	LA78	549000
Mounting bracket, BT 78-100	BT78	50003374
Mounting plate with SLS alignment	BT16	50006902
Deflecting mirror, complete with mounting plate and springs; mirror can rotate by 90°	US2	50017434
Deflecting mirror, without mounting plate and springs, e.g. for column mounting	US2.1	50019628
Deflecting mirror, with integrated mounting plate and springs; mirror cannot rotate	US2.2	50023174
Replacement mirror	US2.3	50023175
Power supply, 120/230 V AC → 24 V DC/5 A, regulated	SITOPpower	520060
Power supply, 120/230 V AC → 24 V DC/1.3 A, regulated	LOGO! power	520061
Test rod, 14 mm/30 mm	AC-TB14/30	349945
MSI-SR4 E-STOP relay, cat. 4	MSI-SR4	549986
Type 4 safety interface, relay output	MSI-s/R	549900
Type 4 safety interface, extended functions, relay output	MSI-sx/Rx	549901
Type 4 safety interface, muting, relay output	MSI-m/R	549904
Type 4 safety interface, muting, relay output, UL/CSA, ext. temperature range, 60 °C	MSI-mE/R	549980

Type 4 safety interface, muting, extended functions, relay output	MSI-mx/Rx	549905
Type 4 safety interface, muting, extended functions, relay output, UL/CSA, ext. temperature range, 60	MSI-mxE/Rx	549982

**Tabelle 11.2-1:** Accessories ordering information

### 11.3 Checklist

The inspection before the initial operation determines the safety related integration of the active opto-electronic protective device (AOPD) into the machine and its control. The results of the inspection must be written down and kept with the machine documents. They can then be used as a reference during the subsequent regular inspections.



**Note:**

*This checklist is intended as a help tool. It supports but does not serve for the inspection before the initial operation or the regular inspections by an expert.*

- Has the safety distance been calculated according to the valid formula for access guarding and is this minimum distance observed between the protective field and the danger area? Yes No
- Are the required beam heights of the lowest and the highest beam complied with (see Chapter 5.2 and chapter 5.4)? Yes No
- If access to the danger area is possible through other routes than the protective field of the AOPD, are the other access options suitable secured by other means? Yes No
- Are the protective device and the control devices in good condition? Yes No
- Are transmitter and receiver fixed against displacement/turning after the alignment? Yes No
- Are all connectors and connection cables in fault-free conditions? Yes No
- Is the start/restart button for resetting the AOPD positioned outside the danger area in line with the specifications so that it cannot be reached from inside? Is there a complete overview over the danger area from the start/restart button position? Yes No
- Are both safety switching outputs (OSSDs) linked into the subsequent machine control unit in accordance with the required safety category? Yes No
- Are the subsequent switching elements controlled by the AOPD, e.g. contactors with positive-guided contacts or safety valves monitored via the feedback circuit (EDM)? Yes No
- Does the actual integration of the AOPD into the machine control unit match the circuit diagrams? Yes No

- Does the AOPD respond correctly when the beam is interrupted and does the start/restart interlock lock when the beam is interrupted? This is absolutely necessary, as the access, not the presence in the danger area is registered. Yes No
- Does the dangerous movement stop immediately if the supply voltage of the AOPD is interrupted and is the start/restart button required to reset the opto-electronic protective device again after the supply voltage returns? Yes No





the sensor people

**EG-KONFORMITÄTS-  
ERKLÄRUNG**

**EC DECLARATION  
OF CONFORMITY**

**DECLARATION CE  
DE CONFORMITE**

Hersteller:

Manufacturer:

Constructeur:

**Leuze electronic GmbH + Co. KG**  
In der Braike 1, PO Box 1111  
73277 Owen, Germany

Produktbeschreibung:

Description of product:

Description de produit:

**Einstrahl-  
SicherheitsLichtschranke,  
Berührungslos wirkende  
Schutzeinrichtung,  
Sicherheitsbauteil nach  
2006/42/EG  
AnhangIV  
SLS 78/R  
Seriennummer siehe  
Typenschild**

**Single Light Beam Safety  
Device,  
Active opto-electronic  
protective  
device,  
safety component in ace. with  
2006/42/EC annex IV  
SLS 78/R  
Serial no. see name plates**

**Barrage immatériel de sécurité  
mono faisceau ,  
Équipement de protection  
électrosensible,  
Élément de sécurité selon  
2006/42/CE annexe IV  
SLS 78/R  
N° série voir plaques  
signalétiques**

Die alleinige Verantwortung für die Ausstellung dieser Konformitätserklärung trägt der Hersteller.

This declaration of conformity is issued under the sole responsibility of the manufacturer.

La présente déclaration de conformité est établie sous la seule responsabilité du fabricant.

Der oben beschriebene Gegenstand der Erklärung erfüllt die einschlägigen Harmonisierungsrechtsvorschriften der Union:

The object of the declaration described above is in conformity with the relevant Union harmonisation legislation:

L'objet de la déclaration décrit ci-dessus est conforme à la législation d'harmonisation de l'Union applicable:

Angewandte EG-Richtlinie(n):

Applied EC Directive(s):

Directive(s) CE appliquées:

**2004/108/EG (≤ 19.04.16)  
2014/30/EG (≥ 20.04.16)  
2006/42/EG**

**2004/108/EC (≤ 19.04.16)  
2014/30/EC (≥ 20.04.16)  
2006/42/EC**

**2004/108/CE (≤ 19.04.16)  
2014/30/CE (≥ 20.04.16)  
2006/42/CE**

Angewandte Normen:

Applied standards:

Normes appliquées:

**EN ISO 13849-1: 2008  
+ AC: 2009**

**CLC/TS 61496-2: 2006**

**EN 61496-1: 2013**

Notified Body  
TÜV NORD CERT GmbH  
Zertifizierungsstelle für Produktsicherheit  
Benannte Stelle 0044  
Langemarckstr. 20  
45141 Essen / 44 205 15 159906

Dokumentationsbevollmächtigter ist der genannte Hersteller, Kontakt: quality@leuze.de.  
Authorized for documentation is the stated manufacturer, contact: quality@leuze.de.  
Autorisé pour documentation est le constructeur déclaré, contact: quality@leuze.de  
2014/30/EG veröffentlicht: 29.03.2014, EU-Amtsblatt Nr. L 96/79-106; 2014/30/EC published: 29.03.2014, EU-Journal No. L 96/79-106; 2014/30/CE publié: Journal EU n° L 96/79-106

*21. 1. 2016*  
Datum / Date / Date      Ulrich Balbach, Geschäftsführer / Managing Director / Gérant

Leuze electronic GmbH + Co. KG  
In der Braike 1  
D-73277 Owen  
Telefon +49 (0) 7321 573-0  
Telefax +49 (0) 7321 573-199  
info@leuze.de  
www.leuze.com  
LEO-ZQM-149-06-FD

Leuze electronic GmbH + Co. KG, Sitz Owen, Registergericht Stuttgart, HRA 230712  
Persönlich haftende Gesellschafterin Leuze electronic, Geschäftsührungs-GmbH,  
Sitz Owen, Registergericht Stuttgart, HRB 230550  
Geschäftsführer: Ulrich Balbach  
USt-IdNr.: DE 145912521 | Zollnummer 2554232  
Es gelten ausschließlich unsere aktuellen Verkaufs- und Lieferbedingungen  
Only our current Terms and Conditions of Sale and Delivery shall apply



You can also download this EC Declaration of Conformity from the Internet under:  
<http://www.leuze.com/sls>

