



Barcode Positioning System BPS 37

Technical Description



© All rights reserved, especially the right of reproduction, distribution and translation. Copying or reproductions in any form require the written consent of the manufacturer.
Changes reflecting technical improvements may be made.

1	General Information	4
1.1	Explanation of Symbols	4
1.2	Declaration of Conformity	4
2	Safety Notices	5
2.1	Safety Standards	5
2.2	Intended Use.....	5
2.3	Working Safely	6
3	Description	8
3.1	BPS 37 device construction	8
3.2	Application	8
3.3	Function	8
3.4	Advantages	9
3.5	Standalone operation	9
4	Technical Data.....	11
4.1	General Specifications BPS 37	11
4.2	LED indicators.....	12
4.3	Dimensioned and Connection Drawings	12
5	Accessories / Order Designation	14
5.1	Accessories	14
5.1.1	Connection units	14
5.1.2	Fastening Accessories.....	16
5.1.3	Connection cable	16
6	Installation	17
6.1	Storage, Transportation	17
6.2	Mounting	17
6.2.1	Device Arrangement	19
6.3	Connection	22
6.3.1	Connecting the BPS 37 (SSI)	22
6.3.2	Connection SSI interface	23
6.3.3	Connection of switching input and output	25
6.3.4	Wire Lengths and Shielding.....	26
6.4	Disassembling, Packing, Disposing	26
7	Commissioning	27
7.1	Measures to be performed prior to the initial commissioning.....	27
7.2	Function Test	27
7.3	Setting the Parameters	27
7.3.1	Parameter sets	28
7.3.2	Service Operating Mode	28

8	Operation	29
8.1	Display Elements	29
9	Communicating with the Device.....	30
9.1	Installing the "BPSCConfig" software	30
9.2	Overview of Commands and Parameters	32
9.2.1	General 'Online' Commands	32
9.2.2	General parameter structure	33
10	Maintenance	34
10.1	General Maintenance Information.....	34
10.2	Repairs, Servicing.....	34

Figure 2.1: Example for the attachment of the sticky label with warning notices 7

Figure 3.1: BPS 37 device construction 8

Figure 3.2: Connection BPS "Stand alone" 10

Figure 3.3: BPS connection with connection unit MA 4.7 10

Table 4.1: General Specifications 12

Figure 4.1: Dimensioned drawing BPS 37 12

Figure 4.2: Scanning curve BPS 37 13

Table 5.1: Accessories / Order Designation 14

Figure 5.1: Connection unit MA 4.7/MA 4D.7 / dimensioned drawing 15

Figure 5.2: Mounting device BT 56 16

Figure 6.1: Mounting example BPS 37 18

Figure 6.2: Beam outlet on the BPS 37 20

Figure 6.3: Application example 21

Figure 6.4: BPS 37 sub-D pin assignments 22

Table 6.1: Connection description BPS 37 23

Figure 6.5: Connection with MA 23

Figure 6.6: Connection BPS direct 24

Figure 6.7: Connection diagram switching inputs and outputs BPS 37 25

Table 6.2: Wire Lengths and Shielding 26

Figure 7.1: Connecting the service interface to a PC or terminal 29

Figure 9.1: Installation window 30

Figure 9.2: Installation directory 31

1 General Information

1.1 Explanation of Symbols

The symbols used in this operating manual are explained below.



Attention!

Pay attention to passages marked with this symbol. Failure to heed this information can lead to injuries to personnel or damage to the equipment.



Attention Laser!

This symbol warns of possible danger through hazardous laser radiation.



Notice!

This symbol indicates text passages containing important information.

1.2 Declaration of Conformity

The barcode positioning system BPS 37 and the optional connection units MA 4.7/MA 4D.7 have been developed and manufactured under observation of the applicable European standards and directives.



Notice!

The corresponding declaration of conformity can be requested from the manufacturer.

The manufacturer of the product, Leuze electronic GmbH & Co KG in D-73277 Owen/Teck, possesses a certified quality assurance system in accordance with ISO 9001.



2 Safety Notices

2.1 Safety Standards

The barcode positioning system BPS 37 and the optional connection units MA 4.7/MA 4D.7 have been developed, produced and tested subject to the applicable safety standards. They correspond to the state of the art.

2.2 Intended Use

**Attention!**

The protection of personnel and the device cannot be guaranteed if the device is operated in a manner not corresponding to its intended use.

Barcode positioning systems of the type BPS 37 are optical measuring systems which use visible red laser light to determine the position of the BPS relative to a permanently mounted barcode band.

Typically, the BPS is mounted on a (rail-)guided vehicle whose position is to be exactly determined.

The position is determined to within a millimetre using the information of the fixed barcode band and made available to the primary system at a suitable interface.

The optional connector and interface units MA 4.7/MA 4D.7 are intended for the easy connection of barcode positioning systems of type BPS 37.

In particular, unauthorised uses include:

- rooms with explosive atmospheres
- operation for medical purposes

Areas of application

The barcode positioning system BPS 37 with optional connection unit MA 4.7/MA 4D.7 has been designed particularly for the following fields of application:

- High-bay storage devices and lifting gear
- Crane systems
- Side-tracking skates
- Transfer machines
- Telfer lines

2.3 Working Safely



Attention Laser Radiation!

The barcode positioning system BPS 37 operates with a red light laser of class 2 acc. to EN 60825-1 (2001/11). It also complies with the U.S. 21 CFR 1040 regulations for a class II product. If you look into the beam path over a longer time period, the retina of your eye may be damaged!

Never look directly into the beam path!

Do not point the laser beam of the BPS 37 at persons!

When mounting and aligning the BPS 37, take care to avoid reflections of the laser beam off reflective surfaces!

The use of operating and adjusting devices other than those specified in this technical description, carrying out of differing procedures, or improper use of the barcode positioning system may lead to dangerous exposure to radiation!

The use of optical instruments or devices in combination with the device increases the danger of eye damage!

Adhere to the applicable legal and local regulations regarding protection from laser beams acc. to EN 60825-1 in its latest version.

The BPS 37 uses a laser diode with low power in the visible red light range with an emitted wavelength of about 650nm. The output power of the laser beam at the reading window is at most 1.8 mW acc. to EN 60825-1 (2001/11).

The reading window is the only opening through which the laser radiation can escape from the device. The housing of the BPS 37 is sealed and has no parts that need to be adjusted or maintained by the user. The device must not be tampered with and must not be changed in any way!



Notice!

It is important that you attach the sticky labels supplied to the device (notice signs and laser emission symbol)! If the signs would be covered due to the installation situation of the BPS 37, attach them close to the BPS 37 such that reading the notices cannot lead to looking into the laser beam!

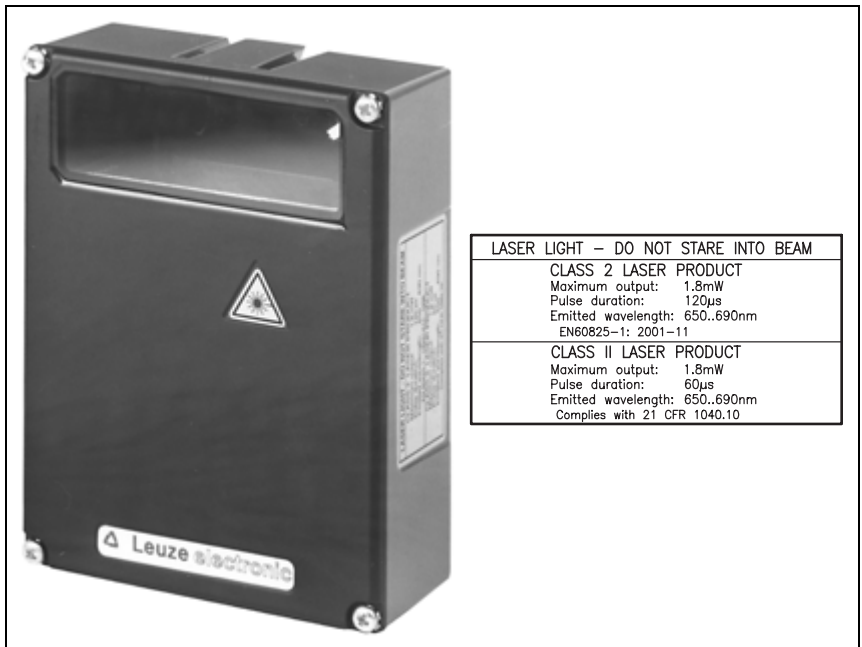

Figure 2.1: Example for the attachment of the sticky label with warning notices



Attention!

Access to or changes on the device, except where expressly described in this operating manual, is not authorised.

Safety regulations

Observe the locally applicable legal regulations and the rules of the employer's liability insurance association.

Qualified personnel

Mounting, commissioning and maintenance of the device must only be carried out by qualified personnel.

Electrical work must be carried out by a certified electrician.

3 Description

Information on technical data and characteristics can be found in chapter 4.

3.1 BPS 37 device construction

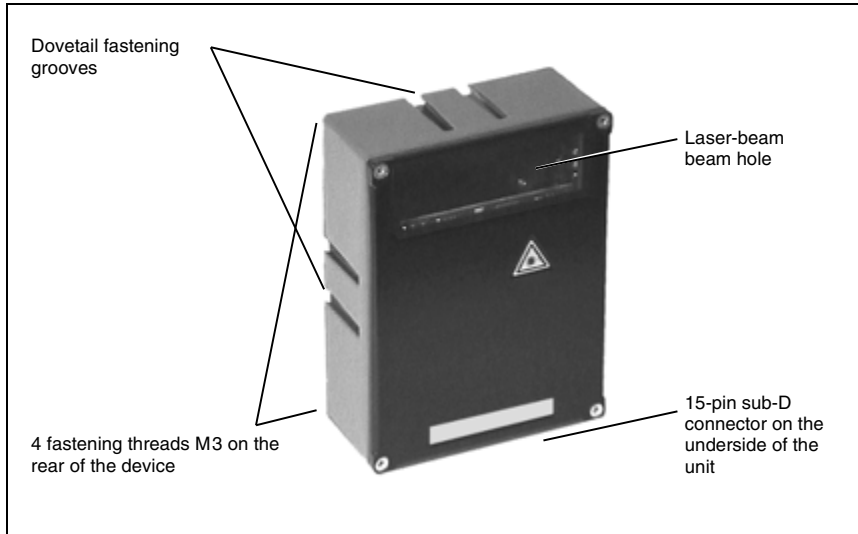

Figure 3.1: BPS 37 device construction

3.2 Application

Anywhere systems are moved automatically, it is necessary to correctly determine their positions. This is achieved using various measurement techniques. In addition to mechanical measurement sensors, optical methods are particularly well suited for determining positions as they operate without mechanical wear and slippage.

Unlike other optical measurement methods, the barcode positioning system is not restricted to linear movements. It can also be used flexibly in curved systems. Anywhere the long-wearing barcode band can be attached, it is possible to use the BPS to determine the position to within a millimetre.

Guide tolerances of the system play no roll as the permitted separation between band and BPS allows for large deviations in distance.

3.3 Function

The BPS uses visible red laser light to determine its position relative to the barcode band. This essentially takes place in three steps:

1. Reading a code on the barcode band
2. Determining the position of the read code in the scanning area of the laser beam
3. Calculating of the position to within a millimetre using the code information and the code position

The position value is then passed on via the standardised SSI interface (synchronous serial interface) to the drive system of the vehicle for which the position is to be determined.

3.4 Advantages

- Easy installation and commissioning
- Teach function for the "zero point", i.e. it is not necessary to exactly affix the barcode band.
- Data output via SSI interface; BPS can be connected instead of a conventional rotation encoder.
- The function of the BPS makes it possible to attach the barcode band only at those locations where it is necessary that the position be known exactly.
- Positioning of non-linear movements as well
- No referencing necessary following voltage drop
- Thanks to the large scanning depth, it is possible to compensate for mechanical tolerances.
- It is possible to exactly determine positions from distances of 10000 metres.

3.5 Standalone operation

The barcode positioning system BPS 37 is operated as a single "stand alone" device. The BPS features a 15-pin sub-D connector for the electrical connection of the supply voltage, the interface and the switching inputs.

With connection units

The connection units simplify the electrical installation of the barcode positioning system in stand-alone operation.

Moreover, they store the operating parameters so that the configuration data are retained even if the BPS is replaced and can show parameters and operating data on a display (MA 4D.7).

A listing of the available connection units and associated short descriptions can be found in chapter 5. Separate data sheets are available that contain further details about the connection units.

Without connection unit MA 4.7/MA4D.7

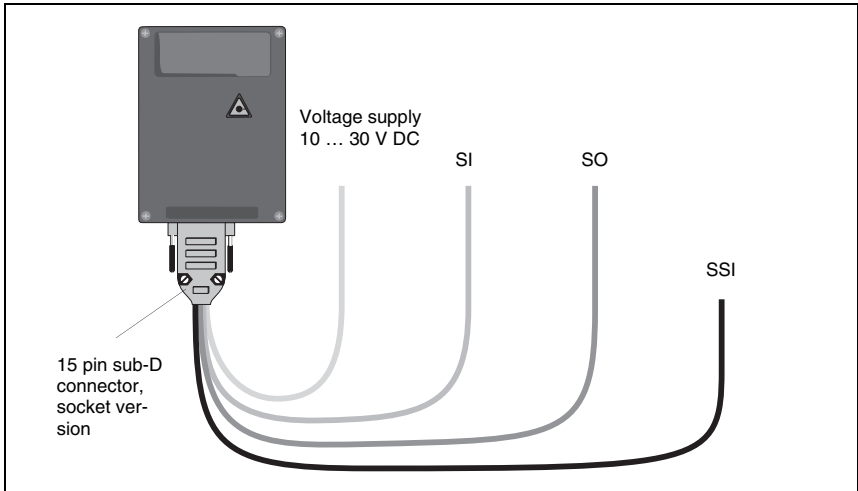

Figure 3.2: Connection BPS "Stand alone"

With connection unit MA 4.7/MA4D.7

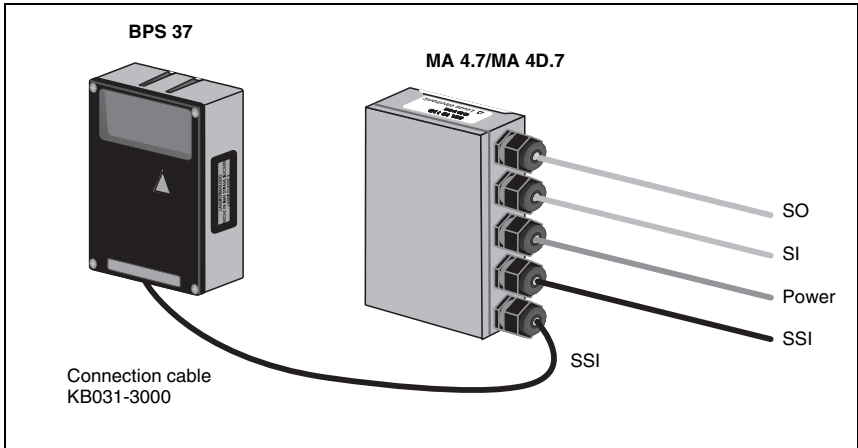

Figure 3.3: BPS connection with connection unit MA 4.7

4 Technical Data

4.1 General Specifications BPS 37

Optical Data

Light source Laser diode 650nm
 Scanning rate 1000scans/sec.

Measurement data

Reproducible accuracy ±1 (2) mm
 Integration time 16 (8) ms
 Measurement value output 500 values/sec.
 Refresh time
 Scanning depth 90 ... 170 mm

Electrical data

Interface type SSI (RS422)
 (standard setting) electrically isolated
 bits 0 ... 24: data bits with position value
 bit 25: error bit
 resolution: 1 mm
 800 kHz max. clock frequency
 output of positive and negative position values
 gray coded
 Service interface RS232 with fixed data format,
 9600Bd, 8 data bits, no parity, 1 stop bit
 Ports 1 switching output, 1 switching input
 LED green device ready (Power On)
 Operating voltage 10 ... 30V
 Power consumption 3.2 W

Mechanical data

Protection class IP 65
 Weight 400 g
 Dimensions (W x H x D) 120 x 90 x 43mm
 Housing diecast aluminium

Environmental data

Operation w/o optics heating 0°C ... +40°C (BPS 37 S M 100)
 Operation with optics heating -30°C ... +40°C (BPS 37 S M 100 H)
 Storage -20°C ... +60°C
 Air humidity max. 90% rel. humidity, non-condensing
 Vibration IEC 68.2.6
 IEC 68.2.27 (shock)
 IEC 801
 Electromagnetic compatibility acc. to IEC 60947-5-2

Barcode band

Max. length (measurement length)	10000m
Ambient temperature	-40°C ... +120°C
Mech. properties	scratch and wipe resistant UV resistant moisture resistant partly chemical resistant

Table 4.1: General Specifications



Notice!

Two models of the BPS 37 are available: **BPS 37 S M 100** without optics heating
BPS 37 S M 100 H with optics heating

4.2 LED indicators

An internal LED indicates in the reading window whether or not the supply voltage is present.

4.3 Dimensioned and Connection Drawings

BPS 37 S M 100 / BPS 37 S M 100 H

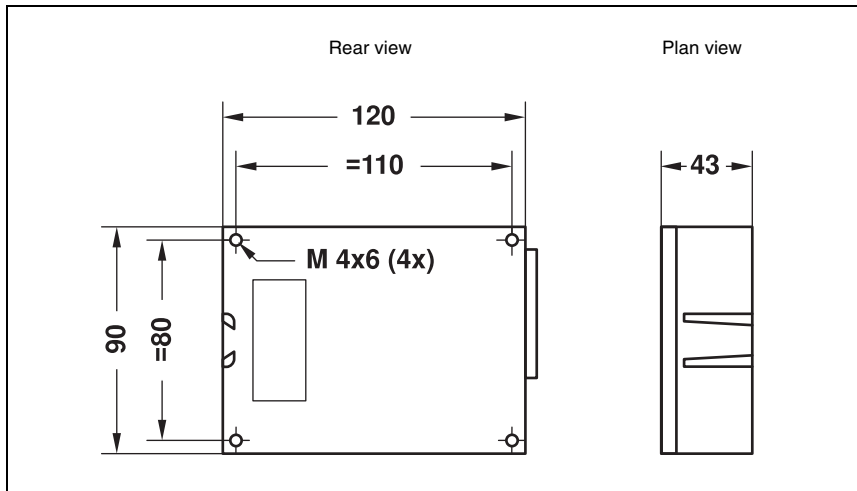

Figure 4.1: Dimensioned drawing BPS 37

Scanning curve BPS 37

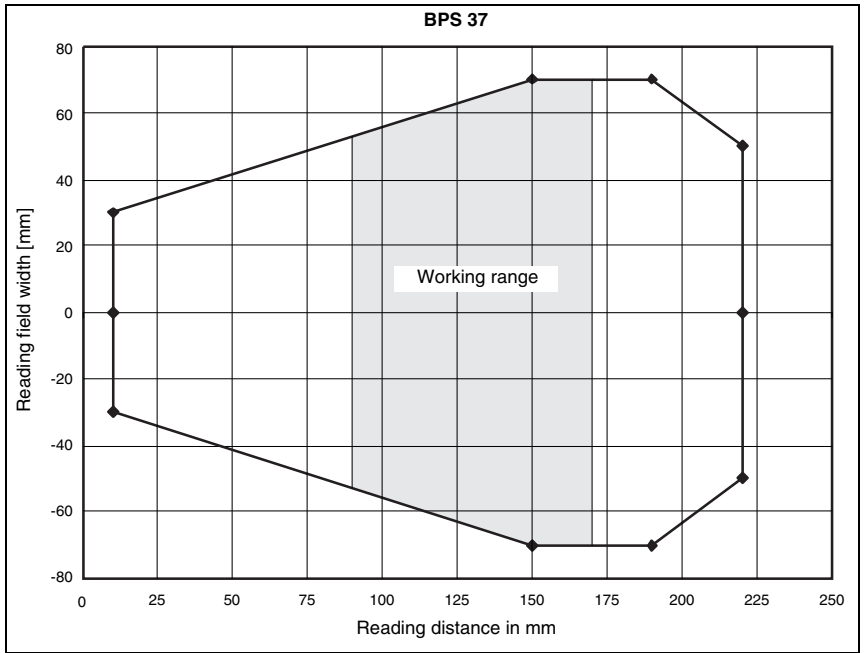

Figure 4.2: Scanning curve BPS 37

5 Accessories / Order Designation

5.1 Accessories



Notice!

Products from Leuze electronic GmbH & Co KG can be ordered from any of the sales and service offices listed on the back page of this operating manual.

Designation	Part No.	Short Description
MA 4.7	500 37324	Connection unit for BPS 37 with parameter memory
MA 4D.7	500 37325	Connection unit for BPS 37 with parameter memory and display
BT 56	500 27375	Mounting device with dovetail for rod
KB 031-3000	500 35355	Connection cable between BPS and MA, length: 3m
BPSConfig	500 60298	Programming software

Table 5.1: Accessories / Order Designation

5.1.1 Connection units



Notice!

The connection units are described here in brief only. For further information regarding the connection units please refer to the relevant data sheets

Connection unit MA 4.7/MA 4D.7

The connection units MA 4.7/MA 4D.7 are used to simplify the electrical installation of the BPS 37. They have the following advantages compared to the installation of the BPS 37 as a standalone device:

- Terminals for switching inputs and outputs, including supply voltage
- 9-pin sub-D plug for service interface
- Operating mode switch: service operation/standard operation
- Code types - changeover switches binary/Gray
- Rotary switch for setting the resolution
- Parameter memory for the BPS - the BPS can be exchanged without the need for reconfiguration.
- Display (MA 4D.7 only)

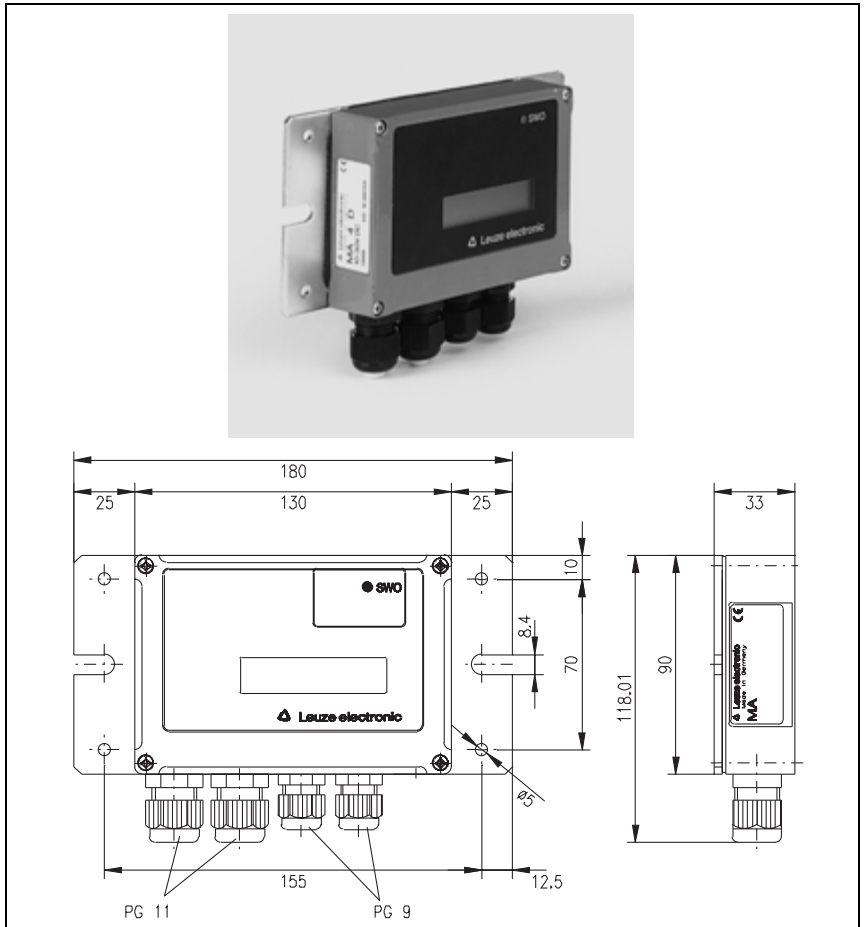

Figure 5.1: Connection unit MA 4.7/MA 4D.7 / dimensioned drawing

5.1.2 Fastening Accessories

The mounting unit BT 56 is available for mounting the BPS 37. It is designed for rod installation.

Mounting device BT 56

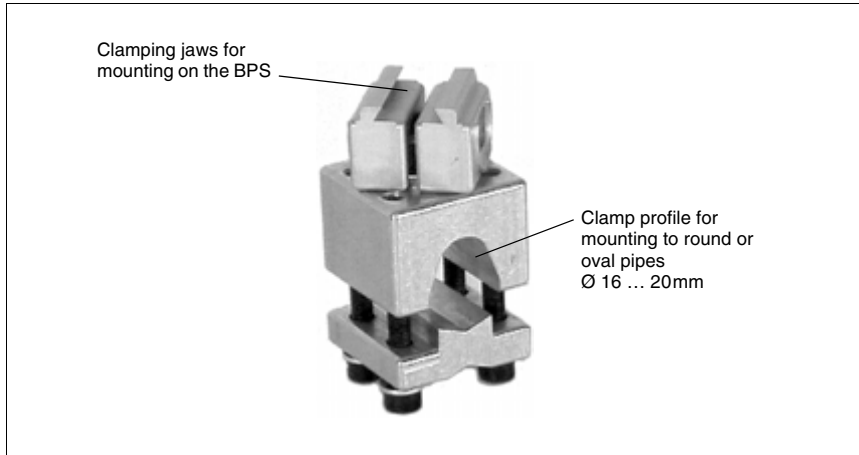

Figure 5.2: Mounting device BT 56

5.1.3 Connection cable

A special connection cable is available for the connection between BPS and connection units. This connection cable may be used for the connection units MA 4.7 as well as for MA 4D.7.

6 Installation

6.1 Storage, Transportation

**Attention!**

When transporting, package the device so that it is protected against collision and humidity. Optimal protection is achieved when using the original packaging. Heed the required environmental conditions specified in the technical data.

Unpacking

- ↪ *Check the packaging for any damage. If damage is found, notify the post office or shipping agent as well as the supplier.*
- ↪ *Check the delivery contents using your order and the delivery papers:*
 - delivered quantity
 - device type and model as indicated on the nameplate
 - accessories
 - operating manual
- ↪ *Save the original packaging for later storage or shipping.*

If you have any questions concerning your shipment, please contact your supplier or your local Leuze electronic sales office.

- ↪ *Observe the local regulations regarding disposal and packaging.*

Cleaning

- ↪ *Clean the glass window of the BPS 37 with a soft cloth before mounting. Remove all packaging remains, e.g. carton fibres or Styrofoam balls.*

**Attention!**

Do not use aggressive cleaning agents such as thinner or acetone for cleaning the device and the barcode band.

6.2 Mounting

Accessories

The mounting system BT 56 is available for installation. It may be ordered separately from Leuze electronic. For order numbers, see table 5.1 "Accessories / Order Designation" on page 14.

Mounting the BPS 37

There are two basic types of mounting arrangements for the BPS 37:

- using the dovetail groove and the corresponding mounting accessories (see figure 6.1)
- using the fastening threads on the back- and underside of the devices (chapter 4.3)

Mounting example BPS 37

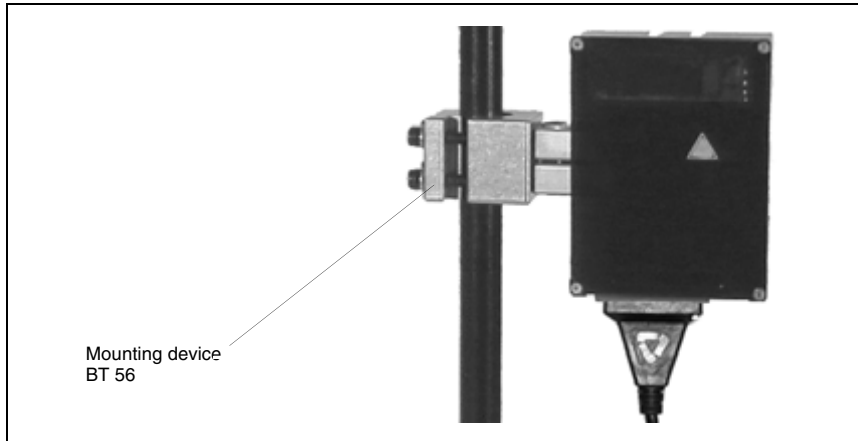

Figure 6.1: Mounting example BPS 37

Mounting MA

You can mount all connection units individually through the holes located on the mounting plate (see figure 5.1).

Subsequently, connect the BPS 37 with the connection unit via the respective cable (see chapter 5.1.3).

6.2.1 Device Arrangement

Selecting a mounting location

In order to select the right mounting location, several factors must be considered:

- The scanning range determined from the scanning curve must be adhered to at all locations at which a position determination is to be made
- The BPS should be mounted inclined 10° from vertical towards the barcode band to ensure that the read results are reliably obtained even if the barcode band is soiled.

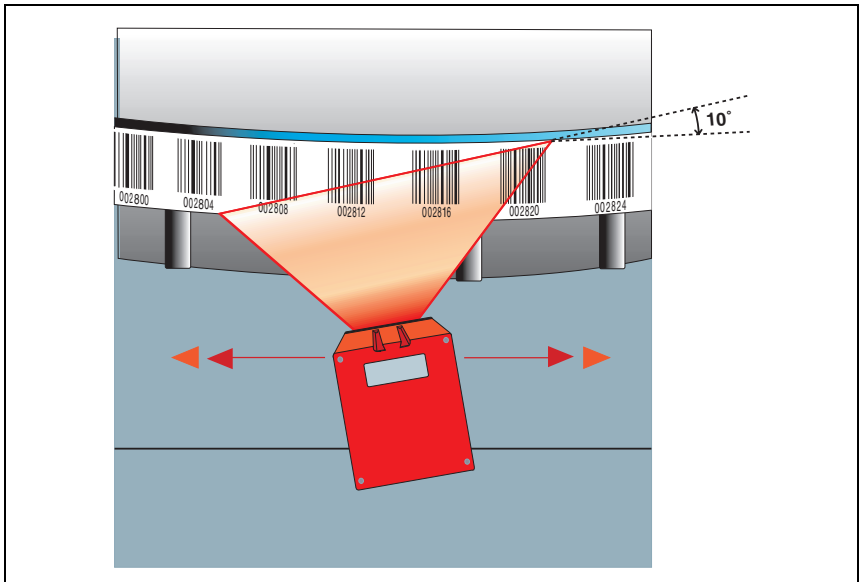

Notice!

The best functionality is obtained when:

- the BPS is guided parallel to the band
- the permitted working range is not exited



Notice!

On the BPS 37, the beam is not emitted perpendicular to the cover of the housing, but with an angle of 10° towards the top. This angle is intended to prevent total reflection on the barcode band.

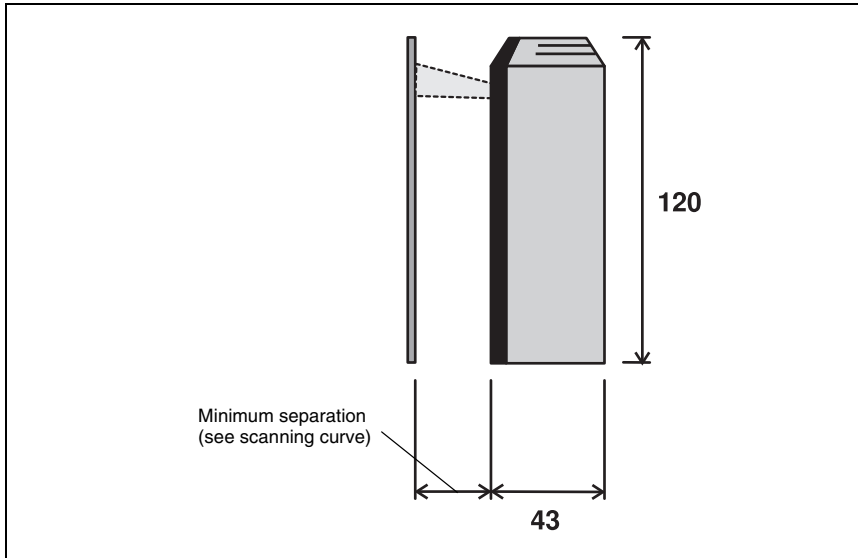

Figure 6.2: Beam outlet on the BPS 37

Mounting location

↳ *When selecting a mounting location, pay attention to*

- maintaining the required environmental conditions (humidity, temperature),
- possible soiling of the reading window due to liquids, abrasion by boxes, or packaging material residues.
- lowest possible chance of damage to the scanner by mechanical collision or jammed parts.

Application example

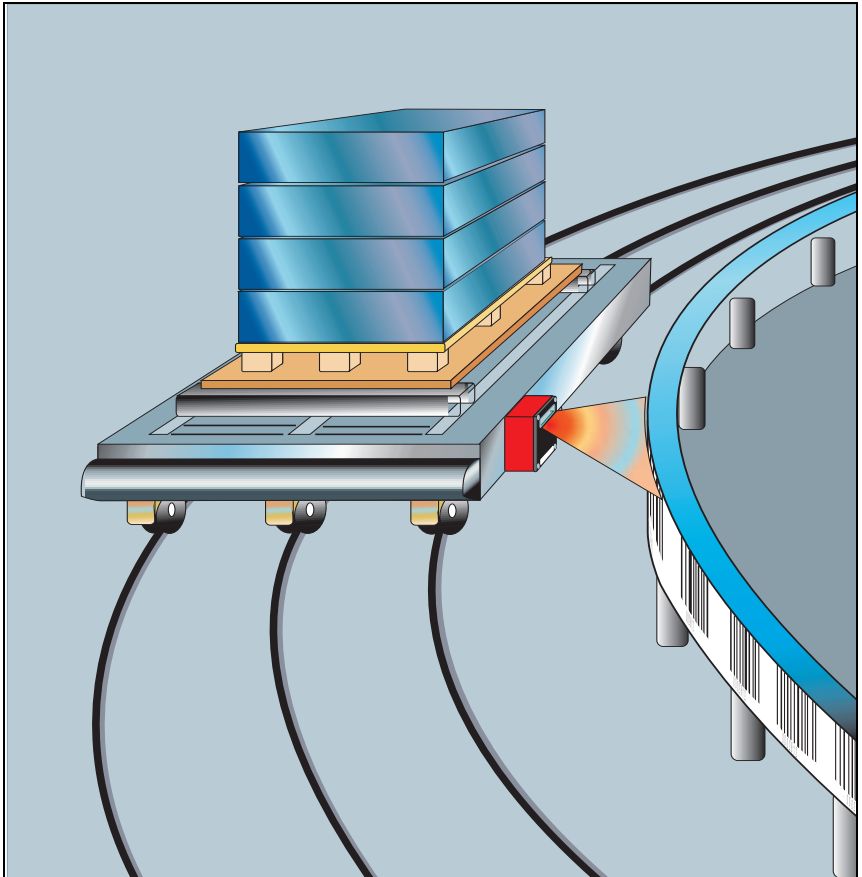

Figure 6.3: Application example

6.3 Connection



Attention!

Never open the device yourself, as this may compromise protection class IP 65.

Before connecting the device, be sure that the supply voltage agrees with the value printed on the nameplate.

Connection of the device and maintenance work while under voltage must only be carried out by a qualified electrician.

The power supply unit for the generation of the supply voltage for the BPS 37 and the respective connection units must have a secure electrical insulation through double insulation and safety transformers according to DIN VDE 0551 (IEC 742).

Be sure that the earthing conductor is connected correctly. Error-free operation is only guaranteed when the device is properly earthed.

If faults cannot be corrected, the device should be removed from operation and protected against possible use.

6.3.1 Connecting the BPS 37 (SSI)

BPS 37 sub-D pin assignments

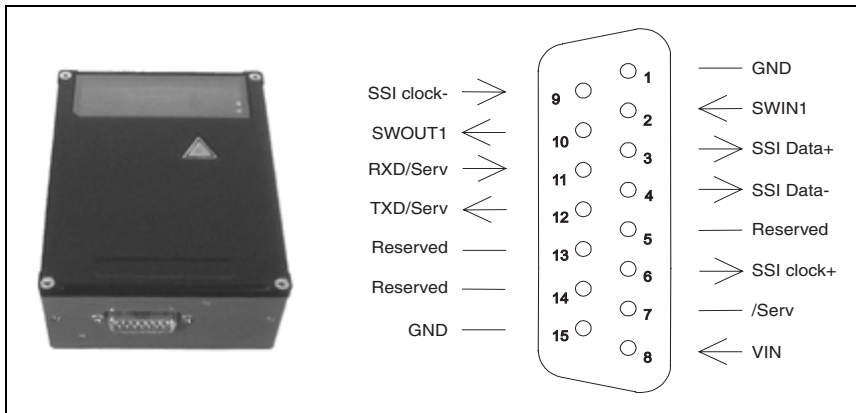

Figure 6.4: BPS 37 sub-D pin assignments

Wiring description

Pin 1	GND	Ground reference RS 232
Pin 2	SWIN1	Switching input 1 (+12 ... 30VDC)
Pin 3	SSI data+	SSI data line
Pin 4	SSI data-	SSI data line
Pin 5	Reserve	
Pin 6	SSI clock+	SSI clock line
Pin 7	/Serv	Bridge to pin 15: service operation via RS232 interface
Pin 8	VIN	Supply voltage +10 ... 30VDC
Pin 9	SSI clock-	SSI clock line
Pin 10	SWOUT1	Switching output 1 (max. 100mA)
Pin 11	RXD/Serv	RXD signal, service interface RS 232
Pin 12	TXD/Serv	TXD signal, service interface RS 232
Pin 13	Reserve	
Pin 14	Reserve	
Pin 15	GND	Supply voltage 0VDC

Table 6.1: Connection description BPS 37

6.3.2 Connection SSI interface

Connection with MA

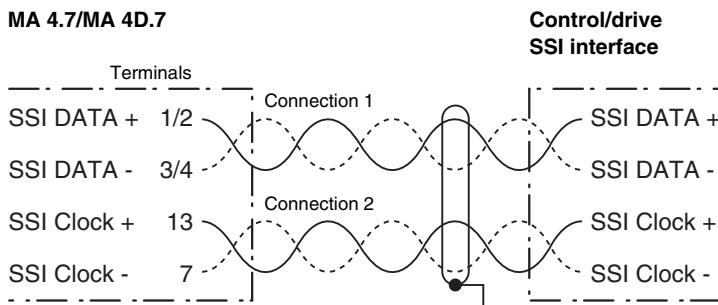

Figure 6.5: Connection with MA

Connection BPS direct

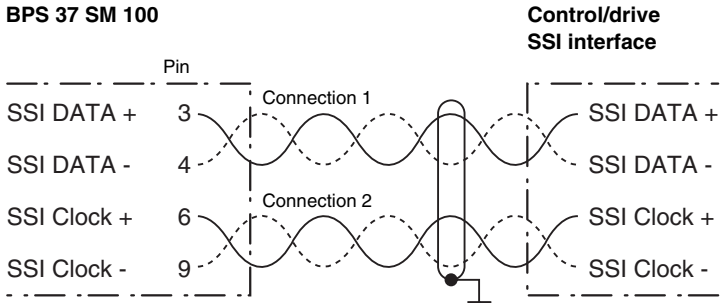

Figure 6.6: Connection BPS direct



Notice!

Ensure adequate shielding. Connections 1 and 2 must be twisted pairs and the total connection line must be shielded and grounded at one end.



Attention!

It is absolutely necessary to connect the protective conductor, since all electrical interference (EM pick-up) is discharged via the protective conductor connection.

Connection of the protective conductor PE

BPS 37 without cable KB 031-3000: connect PE to the housing of the BPS 37 or to the housing of the 15-pin SUB-D connector!

BPS 37 with cable KB 031-3000: connect PE to the wire with bl/wh colour coding or connect it to the shield!

BPS with cable and MA 4.7 (MA 4D.7): connect PE to PIN 21 or PIN 22!

6.3.3 Connection of switching input and output

The BPS 37 is provided with a switching input and a switching output. The connection of the switching input and output is made according to figure 6.7:

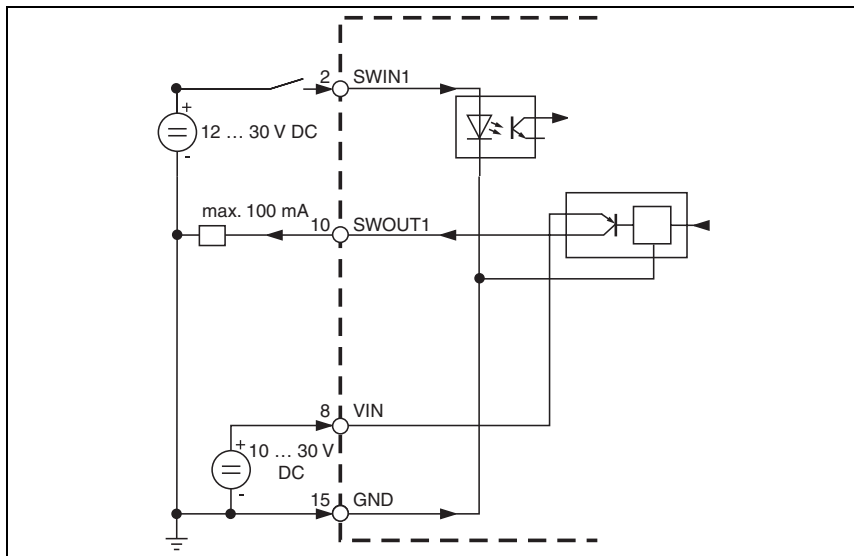

Figure 6.7: Connection diagram switching inputs and outputs BPS 37

Switching input

In the standard setting you can use the switching input connection SWIN1 to reset the output of the position measurement data to zero by applying a voltage of 12 ... 30VDC between SWIN1 (pin 2) and GND (pin 15).

Switching output

The switching output connection between SWOUT1 (pin 10) and GND (pin 15) is normally open. In the standard setting, SWOUT1 is closed in the event of a positioning error.

You can configure the switching inputs and outputs according to your needs, using the supplied BPSConfig program.

6.3.4 Wire Lengths and Shielding

The following maximum lengths for wires and the type of shielding to be used must be observed:

Connecting	Interface	Max. wire length	Shielding
BPS 37 - Service	RS 232	10m	absolutely required, shield meshing
BPS 37/MA 4.7 - Host	SSI	1200m	absolutely required, flexible leads as twisted pairs and shielded
Switching input		10m	not necessary
Switching output		10m	not necessary

Table 6.2: Wire Lengths and Shielding

6.4 Disassembling, Packing, Disposing

Repacking

For later re-use, the device is to be packed so that it is protected against shocks and dampness. Optimal protection is achieved when using the original packaging.



Notice!

Electrical scrap is a special waste product! Observe the locally applicable regulations regarding disposal of the product.

7 Commissioning

7.1 Measures to be performed prior to the initial commissioning

- ↳ *Before commissioning, familiarise yourself with the operation and configuration of the device(s)!*
- ↳ *Before switching on, recheck all connections and ensure that they have been properly made.*

7.2 Function Test

"Power On" test

After connecting the operating voltage, the BPS 37 performs an automatic "Power On" function test. Subsequently, the green LED lights up in the optics window of the BPS 37.

Interface

Proper function of the interface can be tested easiest in service operation using the service interface with the "BPSCfg" programming software and a notebook computer. For order numbers, see table 5.1 on page 14.

Online commands

Using the 'Online' commands, important device functions can be checked, e.g. proper functioning of the laser.

Problems

Should a problem persist after checking all electrical connections and settings on the devices and host, please contact a Leuze service office near you (see the back page of this operating manual).

7.3 Setting the Parameters

You have now commissioned the BPS. Usually, you will have to configure it before you can use it. Using the parameter options made available by the BPS, you can configure the BPS to suit your individual area of application. For instructions regarding the various setting options refer to chapter 9 or to the online help of the BPSCfg program.

The setting is usually accomplished by using the program BPSCfg, see "Installing the "BPSCfg" software" on page 30.

To understand what is happening during the parameter setting, the following chapter 7.3.1 briefly explains the various parameter sets.

The setting of the parameter sets then takes place in the operating mode "service", which is described in chapter 7.3.2.

7.3.1 Parameter sets

In the BPS 37 three different parameter sets are administered:

- parameter set with the default settings in the ROM
- current parameter set in the EEPROM
- working copy of the current parameter set in the RAM

Before a parameter set is loaded into the memory of the BPS 37 processor, the validity of the parameter set is verified using checksums.

Factory default parameter set

This parameter set contains the default settings made ex works for all BPS 37 parameters. It is permanently stored in the ROM of the BPS 37. The parameter set with the default settings is loaded into the memory of the BPS 37,

- the first time the device is commissioned after delivery
- following the command "Factory Default" in the parameterisation program
- if the checksums of the current parameter set are invalid.

Current parameter set

In this parameter set, the current settings for all device parameters are stored. When the BPS 37 is in operation, the parameter set is stored in the EEPROM of the BPS 37. The current set can be stored:

- by copying a valid parameter set from the host computer
- by means of an off-line set-up with the PC set-up program BPSConfig

The current parameter set is loaded into the memory of the BPS 37:

- each time the supply voltage is connected
- following a software reset

The current parameter set is overwritten by the parameter set with the default settings:

- by a parameter reset, see "Online commands" on page 27

7.3.2 Service Operating Mode

Setting the required parameters is carried out easiest in the 'Service' operating mode. The Service operating mode makes the following defined operating parameters available on a separately wired RS232 interface, independent from the BPS's configuration for standard operation:

- transfer rate 9600 baud
- no parity
- 8 data bits
- 1 stop bit
- prefix: STX
- postfix: CR, LF

Service interface active

The service interface is activated via a bridge between the pins 7 and 15 on the 15-pin sub-D connector. If the BPS 37 is operated with a connection unit, the service interface is activated through a switch in the connection unit.

Connection

You can connect a PC or terminal to the BPS 37 via the serial interface and configure the BPS 37 through this connection. For this, you need a crossed RS 232 connection cable (null modem cable) that provides the connections RxD, TxD and GND. The hardware handshake at the service interface is via RTS. A CTS handshake is not supported.

If the BPS is connected to a connection unit, you can use the 9-pin sub-D service connector in the connection unit. For the respective connection specifications please refer to the data sheet of the connection unit.

Service Operating Mode

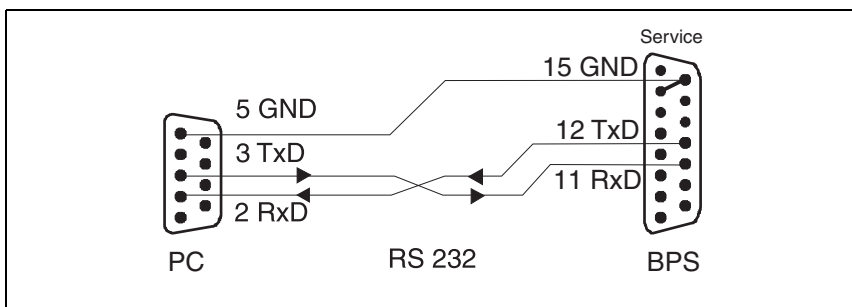

Figure 7.1: Connecting the service interface to a PC or terminal

8 Operation

8.1 Display Elements

On the BPS 37 there is an LED. It signals that the BPS is ready for operation.

9 Communicating with the Device

Device parameters can be set via commands or using the easy-to-use "BPSConfig 3.0" control software.

9.1 Installing the "BPSConfig" software

☞ Place the installation CD in your CD drive.

☞ Call up the installation file (e.g. Set-up.exe)

The following window appears:

Installation window

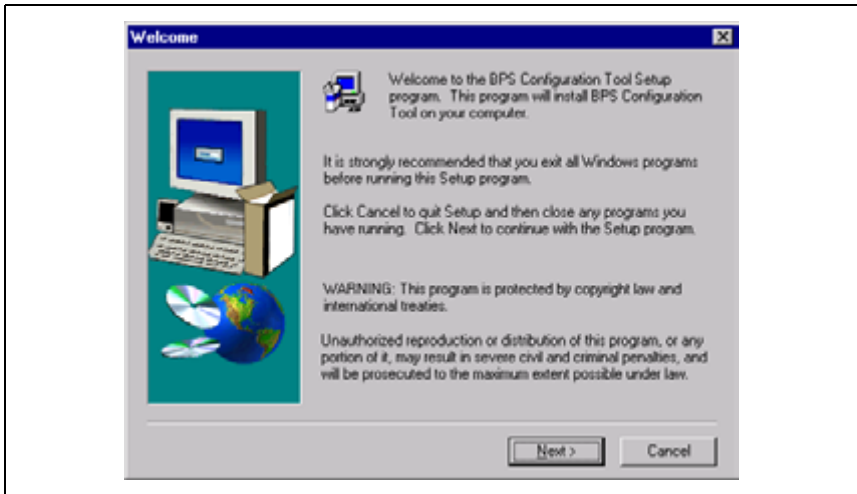

Figure 9.1: Installation window

☞ Confirm the following licence agreement and select the installation path in the following window:

Installation directory

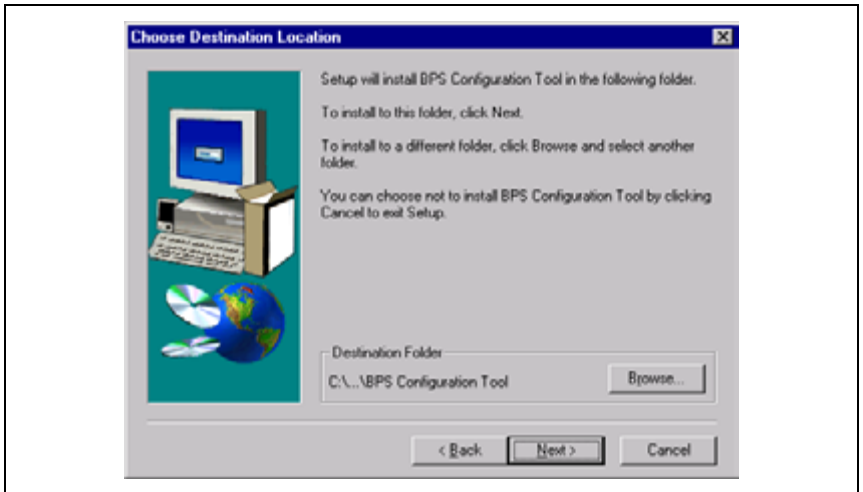

Figure 9.2: Installation directory

↳ Confirm your entry with *Continue*, then follow the installation routine.

For further information, please see the online help for the "BPSConfig" software.

9.2 Overview of Commands and Parameters

Online commands can be used to send commands directly to the device for control and configuration.

For this, the BPS 37 has to be connected to a host or service computer via the serial interface. The commands can be sent either via the host or the service interface.

9.2.1 General 'Online' Commands

Command	Description
M+	Activating the measurement
M-	Deactivating the measurement
MI	Reversing the count direction With the standard setting, the calculation is performed back from the max. measurement length (10000 metre)
MNx=yzzzzzzz	Set pre-set value x = T = value is stored temporarily (the value is erased after switching on and off) x = D = value is stored permanently in the EPROM y = sign for pre-set value zzzzzzz = specification of the pre-set value in mm Example: MND=+0001000 Current position is set permanently to +1000 mm.
MNR	Deactivates the pre-set value. The unformatted measurement value is output.
MMxyyyy	Controls the data output via the service interface x = S = a measurement value is output (Single Shot Mode); subsequent specification of the time not necessary x = T = measurement values are output cyclically; time must be subsequently specified y = time specification in ms Example: MMT0500 Measurement values are output via the service interface in a time interval of 500ms
MM-	Deactivating the function MMTyyyy If the cyclical output via the service interface is no longer required, the function must be deactivated using the command MM.
PC20	Resetting all parameters in the BPS 37 to Leuze default values. Version query

9.2.2 General parameter structure

Using the BPSConfig program, parameters can be changed via the service interface. These parameters are divided into individual folders.

The following folders are available:

Measurement Value Control

The various setting options are contained in the folder Measurement Value Control. These are used for activating or deactivating the measurement process.

Measurement Value Preparation

This folder contains the parameters which can be used to prepare the measurement value. This includes e.g. setting the initial or pre-set value, the scaling setting, the counting direction or the resolution.

Measurement Value Monitoring

Measurement value ranges can be defined in this folder. If the measurement values rise above or drop below these values, the BPS should respond appropriately.

Switching output

In this folder the activation and deactivation as well as the timing of the switching output are defined.

Switching input

Settings can be made in this folder for controlling how the BPS reacts to the application of a 24 V signal.

SSI Interface

This folder contains all settings necessary for integrating the BPS to a control or drive system via an SSI interface.

10 Maintenance

10.1 General Maintenance Information

Usually, the barcode positioning system BPS 37 does not require any maintenance by the operator.

Cleaning

Should it become soiled, clean the glass window of the BPS 37 with a soft cloth.



Notice!

Do not use aggressive cleaning agents such as thinner or acetone for cleaning the device.

10.2 Repairs, Servicing

Repairs to the device must only be carried out by the manufacturer.

- ✎ *Contact your Leuze distributor or service organisation should repairs be required.
For addresses, please refer to the back page of this operating manual.*



Leuze electronic GmbH + Co KG
Postfach 11 11, D-73277 Owen/Teck
Tel. (07021) 5730, Fax (07021) 5731 99
E-mail: info@leuze.de
http://www.leuze.de

Sales and Service

A

Ing. Franz Schmachtl KG
Tel. Int. + 43 (0) 732/7646-0
Fax Int. + 43 (0) 732/785036
E-mail: office.linz@schmachtl.at
http://www.schmachtl.at

ARG

Nortecnica S. R. L.
Tel. Int. + 54 (0) 11/4757-3129
Fax Int. + 54 (0) 11/4757-1088
E-mail: info@nortecnica.com.ar

AUS + NZ

Balluff-Leuze Pty. Ltd.
Tel. Int. + 61 (0) 3/97642366
Fax Int. + 61 (0) 3/97533262
E-mail: balluff_leuze@balluff.com.au

B

Leuze electronic nv/sa
Tel. Int. + 32 (0) 2/2531600
Fax Int. + 32 (0) 2/2531536
E-mail: leuze.info@leuze.be

BR

Leuze electronic Ltda.
Tel. Int. + 55 (0) 11/4195-6134
Fax Int. + 55 (0) 11/4195-6177
E-mail: leuze@leuze.com.br
http://www.leuze.com.br

CH

Leuze electronic AG
Tel. Int. + 41 (0) 1/8340204
Fax Int. + 41 (0) 1/8332626
E-mail: info@leuze.ch

CO

Componentes Electronicas Ltda.
Tel. Int. + 57 (0) 4/3511049
Fax Int. + 57 (0) 4/3511019
E-mail: rigogigu@col3.telecom.com.co

CZ

Schmachtl CZ Spol. SR. O.
Tel. Int. + 420 (0) 2/44001500
Fax Int. + 420 (0) 2/44910700
E-mail: office@schmachtl.cz
http://www.schmachtl.cz

DK

Desim Elektronik APS
Tel. Int. + 45/70220066
Fax Int. + 45/70222220
E-mail: desim@desim.dk

D

Leuze electronic GmbH + Co KG
Geschäftsstelle Dresden
Telefon (0351) 284 1105
Telefax (0351) 284 1103
E-mail: vgd@leuze.de

Lindner electronic GmbH
Vertrieb Nord, Hannover
Telefon (0511) 966057-0
Telefax (0511) 966057-57
E-mail: lindner@leuze.de

W+M planttechnik
Dipl.-Ing. Wörtler GmbH + Co.
Vertrieb West, Wuppertal
Telefon (0202) 37112-0
Telefax (0202) 318495
E-mail: wrmplan@rga-net.de

Leuze electronic GmbH + Co KG
Geschäftsstelle Frankfurt
Telefon (06181) 9177-0
Telefax (06181) 917715
E-mail: vgf@leuze.de

Leuze electronic GmbH + Co KG
Geschäftsstelle Owen/Bad.-Württ.
Telefon (07021) 9850-910
Telefax (07021) 9850-911
E-mail: vgo@leuze.de

Leuze electronic GmbH + Co KG
Geschäftsstelle München
Telefon 08141/5350200
Telefax 08141/5350220
E-mail: vgm@leuze.de

E

Leuze electronic S.A.
Tel. Int. + 34 93/4097900
Fax Int. + 34 93/4903515
E-mail: leuze@leuze.net

ET

APLUS Systems
Tel. int. + 20 (0) 2/ 4189036
Fax int. + 20 (0) 2/ 4141280
E-mail: ellfaf@aplusystems.com.eg

F

Leuze electronic sarl.
Tel. Int. + 33 (0) 1/60051220
Fax Int. + 33 (0) 1/60050365
E-mail: infos@leuze-electronic.fr
http://www.leuze-electronic.fr

FIN

SKS-automaatio
Tel. Int. + 358 (0) 9/852661
Fax Int. + 358 (0) 9/8526820
E-mail: automaatio@sksf.fi
http://www.sksf.fi

GB

Leuze Mayser electronic Ltd.
Tel. Int. + 44 (0) 1480/408500
Fax Int. + 44 (0) 1480/403808
E-mail: mail@leuzemayser.co.uk
http://www.leuzemayser.co.uk

GR

UTECO A.B.E.E.
Tel. Int. + 30 (0) 210/4210050
Fax Int. + 30 (0) 210/4212033
E-mail: uteco@uteco.gr

RUS + EST + LV + LT

All Impex GmbH
Tel. + Fax + 7 095/ 9332097
E-mail: adz-sensor@narod.ru

H

Kvalix Automatik Kft.
Tel. Int. + 36 (0) 1/3990615
Fax Int. + 36 (0) 1/3698488
E-mail: info@kvalix.hu
http://www.kvalix.hu

HK

Sensortech Company
Tel. Int. + 852/26510188
Fax Int. + 852/26510388
E-mail: sensortech@netvigator.com

I

IVO Leuze Vogtle Malanca s.r.l.
Tel. Int. + 39 02/26 110643
Fax Int. + 39 02/26 110640
E-mail: ivoleuze@tin.it
http://www.ivoleuze.com

IL

Galoz electronics Ltd.
Tel. Int. + 972 (0) 3/9023456
Fax Int. + 972 (0) 3/9021990
E-mail: admin@galoz.co.il

IND

Global Tech Corp.
Tel. Int. + 91 (0) 20/4470085
Fax Int. + 91 (0) 20/4470086
E-mail: global_tech@vsnl.com

J

C. Illies & Co., Ltd.
Tel. Int. + 81 (0) 3/34431111
Fax Int. + 81 (0) 3/34434118
E-mail: tyo-mp@illies.de
http://www.illies.de

KOR

Leuze electronic Co., Ltd.
Tel. Int. + 82 (0) 31/3828228
Fax Int. + 82 (0) 31/3828522
E-mail: hgshim@leuze.co.kr
http://www.leuze.co.kr

MAL

Ingermark (M) SDN.BHD
Tel. Int. + 60 (0) 3/60342788
Fax Int. + 60 (0) 3/60342188
E-mail: ingmal@tm.net.my

MEX

Leuze Lumiflex México, S.A. de C.V.
Tel. Int. + 52 (0) 81/83524060
Fax Int. + 52 (0) 81/83524034
E-mail: info@leuzemexico.com.mx
http://www.leuze.de

N

Elteco A/S
Tel. Int. + 47 (0) 35/573800
Fax Int. + 47 (0) 35/573849
E-mail: firmapost@elteco.no
http://www.elteco.no

NL

Leuze electronic B.V.
Tel. Int. + 31 (0) 418/653544
Fax Int. + 31 (0) 418/653808
E-mail: info@leuze.nl
http://www.leuze.nl

P

LA2P, Lda.
Tel. Int. + 351 (0) 21/4447070
Fax Int. + 351 (0) 21/4447075
E-mail: la2p@ip.pt
http://www.la2p.pt

PL

Balluff Sp. z. o. o.
Tel. Int. + 48 (0) 22/6519679
Fax Int. + 48 (0) 22/8429728
E-mail: balluff@balluff.pl

RCH

Imp. Tec. Vignola S.A.I.C.
Tel. Int. + 56 (0) 32/256521
Fax Int. + 56 (0) 32/258573
E-mail: vignova@entelchile.net

ROC

Great Cofue Technology Co., Ltd.
Tel. Int. + 886 (0) 2/29838077
Fax Int. + 886 (0) 2/29853373
E-mail: service@cofue.com.tw

RO

O Boyle s.v.l.
Tel. Int. + 40 (0) 5620 1346
Fax Int. + 40 (0) 5622 1036
E-mail: oboyle@rdlink.ro
http://www.oboyle.ro

RSA

Countpulse Controls (PTY.) Ltd.
Tel. Int. + 27 (0) 11/6157556
Fax Int. + 27 (0) 11/6157513
E-mail: clive@countpulse.co.za

S

Leuze SensorGruppen AB
Tel. + 46 (0) 8/7315190
Fax + 46 (0) 8/7315105
E-mail: info@leuze.se

SGP + RI + RP

Balluff Asia Pte Ltd
Tel. Int. + 65/62524384
Fax Int. + 65/62529060
E-mail: balluff@balluff.com.sg

SK

Schmachtl SK s.r.o.
Tel. Int. + 421 (0) 2/54789293
Fax Int. + 421 (0) 2/54772147
E-mail: office@schmachtl.sk

SLO

Tipteh d.o.o.
Tel. Int. + 386 (0) 1/2005150
Fax Int. + 386 (0) 1/2005151
E-mail: info@tipteh.si
http://www.tipteh.si

TH

Industrial Electrical Co. Ltd.
Tel. Int. + 66 (0) 2/6 42-6700
Fax Int. + 66 (0) 2/6 42-4249
E-mail: iec@ie.co.th

TR

MEGA Teknik elek. San. ve Tic. Ltd.
Tel. Int. + 90 (0) 212/3200411
Fax Int. + 90 (0) 212/3200416
E-mail: mega@netone.com.tr
http://www.megateknik.com

USA + CDN

Leuze Lumiflex Inc.
Tel. Int. + 1 (0) 973/5860100
Fax Int. + 1 (0) 973/5861590
E-mail: info@leuze-lumiflex.com
http://www.leuze-lumiflex.com

VC

TR Electronic GmbH
Shanghai Rep. Office
Tel. Int. + 86(0)21/ 58314825
Fax Int. + 86(0)21/ 58314829
E-mail: tr-electronic@online.sh.cn