

Original operating instructions

LV443B.XR/LV443B

Fiber optic amplifier

IMPLEMENTATION AND OPERATION



© 2026

Leuze electronic GmbH + Co. KG

In der Braike 1

D-73277 Owen / Germany

Phone: +49 7021 573-0

Fax: +49 7021 573-199

<http://www.leuze.com>

info@leuze.de

1	About This Document	2
1.1	EC Declaration of Conformity	2
1.2	Download Area	2
2	Safety	3
3	Device Description	4
3.1	Specification	4
3.2	Outline Dimensional Diagram	4
3.3	Setting	5
3.3.1	Input-Output Circuit Diagram	5
3.3.2	Output Switching Method	5
4	Functions	6
4.1	Object Detection – 2 Point Teach	6
4.2	Strengthen Dust and Pollution Resistance	6
4.2.1	Maximum Sensitivity Adjustment (Only LV443B.XR)	6
4.3	Automatic Adjustment	7
4.3.1	Adjust With Moving Detection Object	7
4.4	Position Adjustment (Only LV443B.XR)	7
4.4.1	Confirm the Detection Object Position	7
4.4.2	Intelligent Adjustment Error	8
4.5	Threshold Fine-Tuning	8
4.6	Settings	8
4.6.1	Light Intensity Adjustment (Only LV443B.XR)	8
4.6.2	Reliable Detection Against Dust and Dirt Altering the Incoming Light Level (Only LV443B.XR)	9
4.6.3	Setting Initialization	9
4.6.4	Reset Incoming Light to Display "0" (Only LV443B.XR)	10
4.7	Detail Setting	10
4.8	Installation of Fiber Optic Sensors	13
4.8.1	Install to DIN Rail	13
4.8.2	Remove From DIN Rail	13
4.8.3	Fiber Optic Cutter	13
4.8.4	Install Fiber Optic	13
5	Error Indication	15
6	Maintenance (Troubleshooting)	16
7	Service and Support	16

1 About This Document

1.1 EC Declaration of Conformity

The device meets the basic requirements and the other relevant provisions of the machinery directive 2006/42/EC.



The manufacturer of the product, Leuze electronic GmbH & Co KG in D-73277 Owen, possesses a certified quality assurance system in accordance with ISO 9001.

1.2 Download Area

You can find the original operating instructions and the EU Declaration of Conformity by entering the part number of the device in the search field on our website www.leuze.com.

The part number can be read on the name plate of the device under the "Part No." entry.

2 Safety

 WARNING	
	<p>To ensure the safe operation of the machine, it is necessary to supply electricity with a fixed amount of power source.</p> <p>This product does not belong to explosion-proof structure. Do not use it in flammable or explosive environment.</p> <p>This product should not be used for human protection devices and human testing purposes.</p>

NOTE	
	<ul style="list-style-type: none">⌘ Do not use in places where water, oil or chemicals are used.⌘ Do not use in direct sunlight.⌘ Do not use in places with corrosive gas.⌘ Do not use in places with strong electric and magnetic fields.⌘ Do not use in places where vibration and shock exceed the rated range.⌘ Do not use in places with high temperature and easy condensation.⌘ Do not use in case of damaged shell.⌘ Please correctly connect the load.⌘ Do not load short circuit, otherwise it will lead to damage, cause fire danger.⌘ Please pay attention to the polarity of the power supply to prevent wrong wiring.⌘ Please separate the sensor from the high-voltage line and power line. If the same line is used, it will induce each other and cause wrong action or damage.⌘ Do not disassemble, repair or modify this product without permission.

3 Device Description

3.1 Specification

Series	LV443B.XR / LV443B (Fiber Amplifier)		
Light Source	Red 4 element LED (625nm)		
Supply Voltage	DC12~24 ±10% (VPP) <10%		
Switching Mode	Light ON / Dark ON (Selectable)		
Output Mode	NPN / PNP (Separate variant)		
Control Output:	Load supply voltage: 26.4VDC Max. load current: <100mA Max.		
Response Time	Product Type	LV443B.XR	LV443B
	High Speed (HS)	250µs	250µs
	Standard (STD)	1ms	1ms
	High Precision (LR)	18ms	-
Protection Circuit	Power supply reverse polarity protection		
	Output short circuit protection		
	Output with reverse protection		
Ambient Humidity	25%~85%RH (No dew)		
Operating Temperature Range	-10~55°C (No dew)		
Material Quality	Case: ABS, standard cable (black) PVC		

3.2 Outline Dimensional Diagram

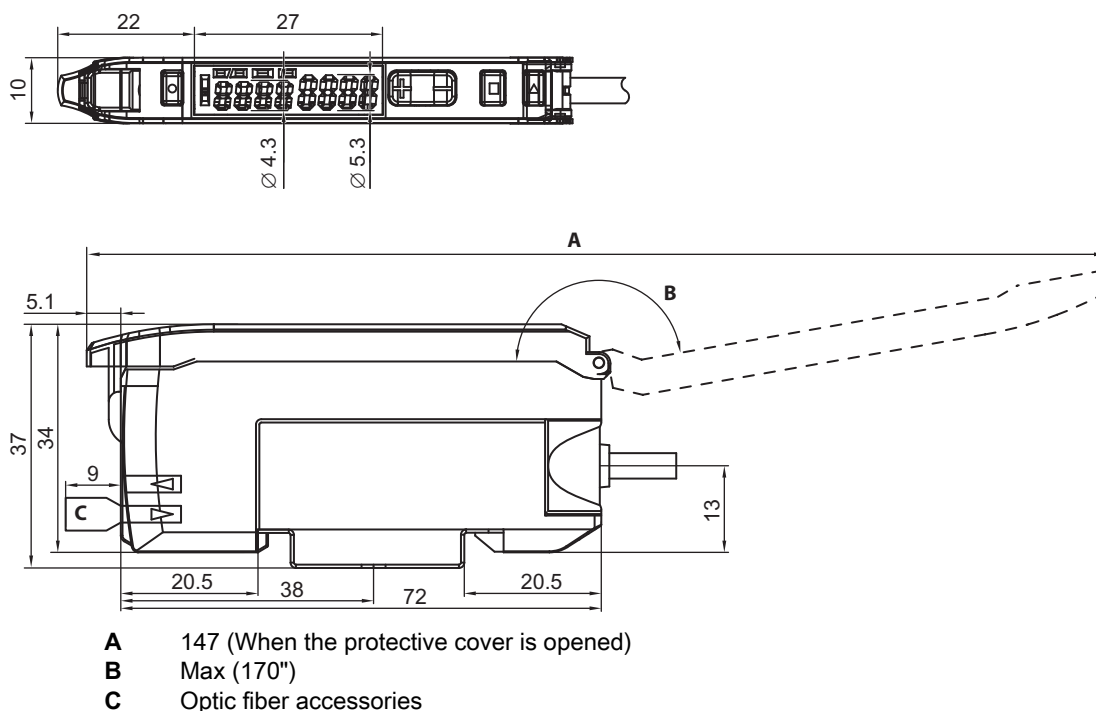
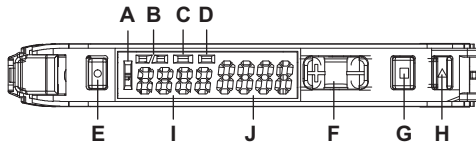

Figure 3.1: Outline Dimensional Diagram

3.3 Setting



- A** Orange LED: on when output is triggered
- B** L/D indicator
D: Dark-on
L: Light-on
- C** ACC indicator orange LED: on when Adaptive Compensation Control is enabled
- D** Blue LED: on when ST (Smart Teach) is pressed
- E** Teach button: performs ST
- F** Threshold setting: fine tuning Up (+) and Down (-)
- G** Mode selector
- H** Light-on/Dark-on switch
- I** Switching threshold: green 4-digit display
- J** Incoming Light level: red 4-digit display

Light Intensity adjustment	
Setting initialization	
Button locked	
Reset to "0"	

- + Press simultaneously
- > Press in sequence

See chapter 4.6 "Settings".

3.3.1 Input-Output Circuit Diagram

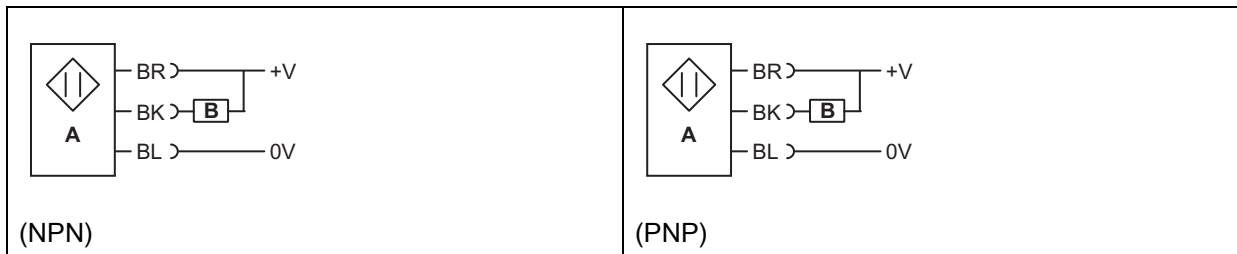

- A** Main Control Circuit
- BR** Brown
- BK** Black
- BL** Blue

3.3.2 Output Switching Method

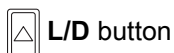



Through beam type (with object detected):
 "ON" when Dark-on, "OFF" when Light-on (L/D indicator light) **D** is on.
Diffuse reflective type (with object detected):
 "OFF" when Dark-on, "ON" when Light-on (L/D indicator light) **L** is on.



4 Functions

4.1 Object Detection – 2 Point Teach

1. Press the **ST** button  when the object is in position.
2. Press the **ST** button  again when the object is removed.

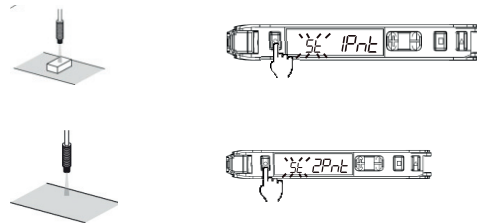

→ Setting is finished.

Smart Teach setting: adjust the light intensity according to the incoming light taught during 2 point teach.

Threshold setting: threshold is set to the middle after Smart Teach is performed on step 1 and step 2.

NOTE



The order of 1 and 2 can be reversed.

4.2 Strengthen Dust and Pollution Resistance

4.2.1 Maximum Sensitivity Adjustment (Only LV443B.XR)

1. Press and hold the **ST** button  for more than 3 seconds and release the button when (FULL) appeared.

Through beam type: perform when object is present

Diffuse reflective type: perform when no object is present.

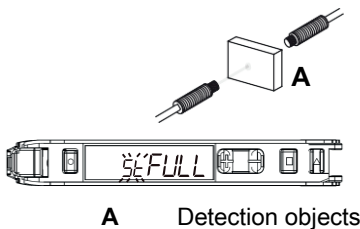

↪ Press more than 3 seconds

Red digits switch from (1Pnt) to (FULL).



Smart Teach setting: incoming light is adjusted to "0"

Threshold setting: threshold is set 7% above the Incoming Light level during teach.



4.3 Automatic Adjustment

4.3.1 Adjust With Moving Detection Object

LV443B.XR:

1. Press **ST** button  and hold for 3 seconds to switch from (IPnt) to (FULL) and continue to hold for another 4 seconds to select (Auto). Release **ST** button  when object is not present.

LV443B:

1. Press **ST** button  and hold for 3 seconds to switch from (IPnt) to (Auto). Release **ST** button  when object is not present.

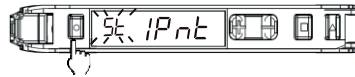
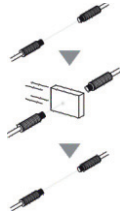

2. Press the button for more than 7 seconds.



→ Setting is finished.

Smart Teach setting: adjust the maximum incoming light.

Threshold setting: threshold value is set to the average value between the maximum and minimum amount of light received during the teach process.

4.4 Position Adjustment (Only LV443B.XR)

4.4.1 Confirm the Detection Object Position

1. Press the **ST** button  when there is no object present.

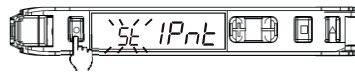

2. Place object in the desired position and press **ST** button  once again and hold for 3 seconds, the red display will change mode from (2Pnt) to (PoS).

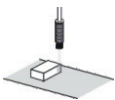

Smart Teach Setting: the Incoming Light level is adjusted to half the adjusted light intensity.

Threshold setting: set to the same value as the amount of light received in step 2.

4.4.2 Intelligent Adjustment Error

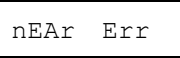
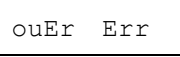
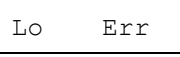
Error Name / Display / Reason	Type of Adjustment	Countermeasure
Near Error  Difference between the amount of light received at set point 1 and set point 2 is too low	2-point Automatic adjustment and Positioning adjustment	<ul style="list-style-type: none"> ↺ Switch to a mode where the Response Time of the amplifier is slower. ↺ Decrease the distance between sender and receiver (Through beam type). ↺ Move the fiber closer to the detected object (Diffuse reflective type).
Over Error  Too much incoming light	All	<ul style="list-style-type: none"> ↺ Increase the light adjustment level. ↺ Use a small-diameter fiber. ↺ Increase the sensing distance between transmitter and receiver (Through beam type). ↺ Move the fiber away from the detecting object (Diffuse reflective type).
Low Error  Too little incoming light	Beyond Maximum Sensitivity adjustment	<ul style="list-style-type: none"> ↺ Reduce the light adjustment level. ↺ Reduce the sensing distance between transmitter and receiver (Through beam type). ↺ Bring the sensor closer to the object (Diffuse reflective type).

NOTE

 The adjustment range of the intelligent adjustment is about 20-1/100 times. When the Detection Function is selected as **LR** mode, the range of adjustment is about 1.6 ~ 1/100 times because the initial value is large.

To change the level of light intensity, see chapter 4.7 "Detail Setting".

4.5 Threshold Fine-Tuning

- Set threshold via **UP/DOWN** button  setting.

NOTE

 Continuous press button for quick adjustment of threshold value.

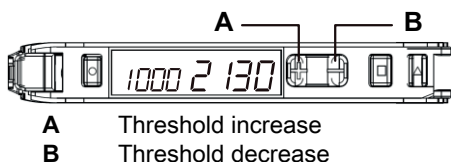

4.6 Settings

4.6.1 Light Intensity Adjustment (Only LV443B.XR)

Restore Light Changes Caused by Dust or Dirt

- When no object is present, press button  and **MODE** button  continuously for more than 1 second.

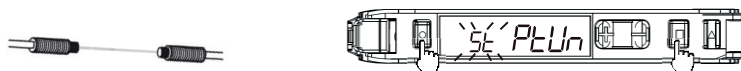

- ↪ Press more than 1 second.
- Setting is finished.

Smart Teach setting: the intensity of the emitted light is set to the optimal level.

Threshold setting: the intensity does not change when the Incoming Light level is low. It is set to the minimum value where an output is turned ON/OFF correctly.

The position adjustment should be performed when a detection object is present.

4.6.2 Reliable Detection Against Dust and Dirt Altering the Incoming Light Level (Only LV443B.XR)

ACC Function

ACC Function is recommended for Through beam type product.

1. Perform Smart Teach (ST) see chapter 4.6 "Settings".
2. Turn on the ACC Function in Setting mode.

NOTE	
	Step 1 and 2 may be reversed.

↪ The ACC Function will be turned off when the Smart Teach leads to an error / Incoming Light level is low.

↪ The Incoming Light level is adjusted to the light intensity to ensure stable threshold.

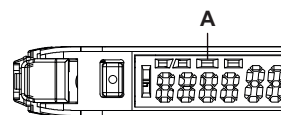

A Indicates that the light will turn on when the ACC Function is valid

With these settings, the sensor is not affected by dust, dirt, temperature change, or positioning fault.

Incoming Light level

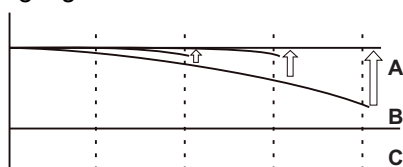







- A** Correct internal Incoming Light level to keep display value stable.
- B** Internal Incoming Light level
- C** Time

If the Incoming Light level cannot be corrected, the value of the red digit decreases and ACC flashes to indicate that correction is not possible.

4.6.3 Setting Initialization

Initialize all settings and return to factory state.

1. Press **ST** button  and **L/D** button  and hold for 3 seconds.
2. Press **MODE** button  once.
3. Select (rSt no) through **UP/DOWN** button  and press **MODE** button  to confirm.

NOTE	
	Please note that pressing L/D button  will inverse the output mode.



☞ Press more than 3 seconds.

Item	Initial Value	
	LV453B.XR	LV443B
Threshold	55	60
Control output	L-ON	L-ON

* All other setting functions are turned off again.

4.6.4 Reset Incoming Light to Display "0" (Only LV443B.XR)

Displays the Incoming Light level as "0" and the threshold changes accordingly.

• Enable



☞ Press both buttons at the same time for more than 3 seconds.

• Disable



☞ Press both buttons at the same time for more than 3 seconds.

NOTE	
	After performing the ACC Function the reset function is disabled.

4.7 Detail Setting

Press **MODE** button for more than 3 seconds to switch to

☞ Setting mode

In Setting mode, the following functions can be selected by following the instruction below.

☞ The initial function shown is the factory default.

Function Setting	Function Instruction												
<p style="text-align: center;">A</p> <p>1. FS</p>	<p>Change Function Setting (FS) in Setting mode.</p> <table border="1"> <tr> <td>dFLt</td> <td>Function Setting 1~5</td> </tr> <tr> <td>oPt</td> <td>Function Setting 1~11</td> </tr> </table>	dFLt	Function Setting 1~5	oPt	Function Setting 1~11								
dFLt	Function Setting 1~5												
oPt	Function Setting 1~11												
<p>2. Detection Function</p> <p>(a) HS 500 </p> <p>(b) STD 500 </p> <p>(c) LR 6000 </p>	<p>Change the Incoming Light level and Response Time.</p> <table border="1"> <thead> <tr> <th>Detection Function</th> <th>Response Time</th> <th>Light Intensity</th> </tr> </thead> <tbody> <tr> <td>(a) HS High Speed mode</td> <td>250µs</td> <td>1 (benchmark)</td> </tr> <tr> <td>(b) STD Standard mode</td> <td>1ms</td> <td>1 Times</td> </tr> <tr> <td>(c) LR Long Range mode (Only LV443B.XR)</td> <td>18ms</td> <td>12 Times</td> </tr> </tbody> </table>	Detection Function	Response Time	Light Intensity	(a) HS High Speed mode	250µs	1 (benchmark)	(b) STD Standard mode	1ms	1 Times	(c) LR Long Range mode (Only LV443B.XR)	18ms	12 Times
Detection Function	Response Time	Light Intensity											
(a) HS High Speed mode	250µs	1 (benchmark)											
(b) STD Standard mode	1ms	1 Times											
(c) LR Long Range mode (Only LV443B.XR)	18ms	12 Times											

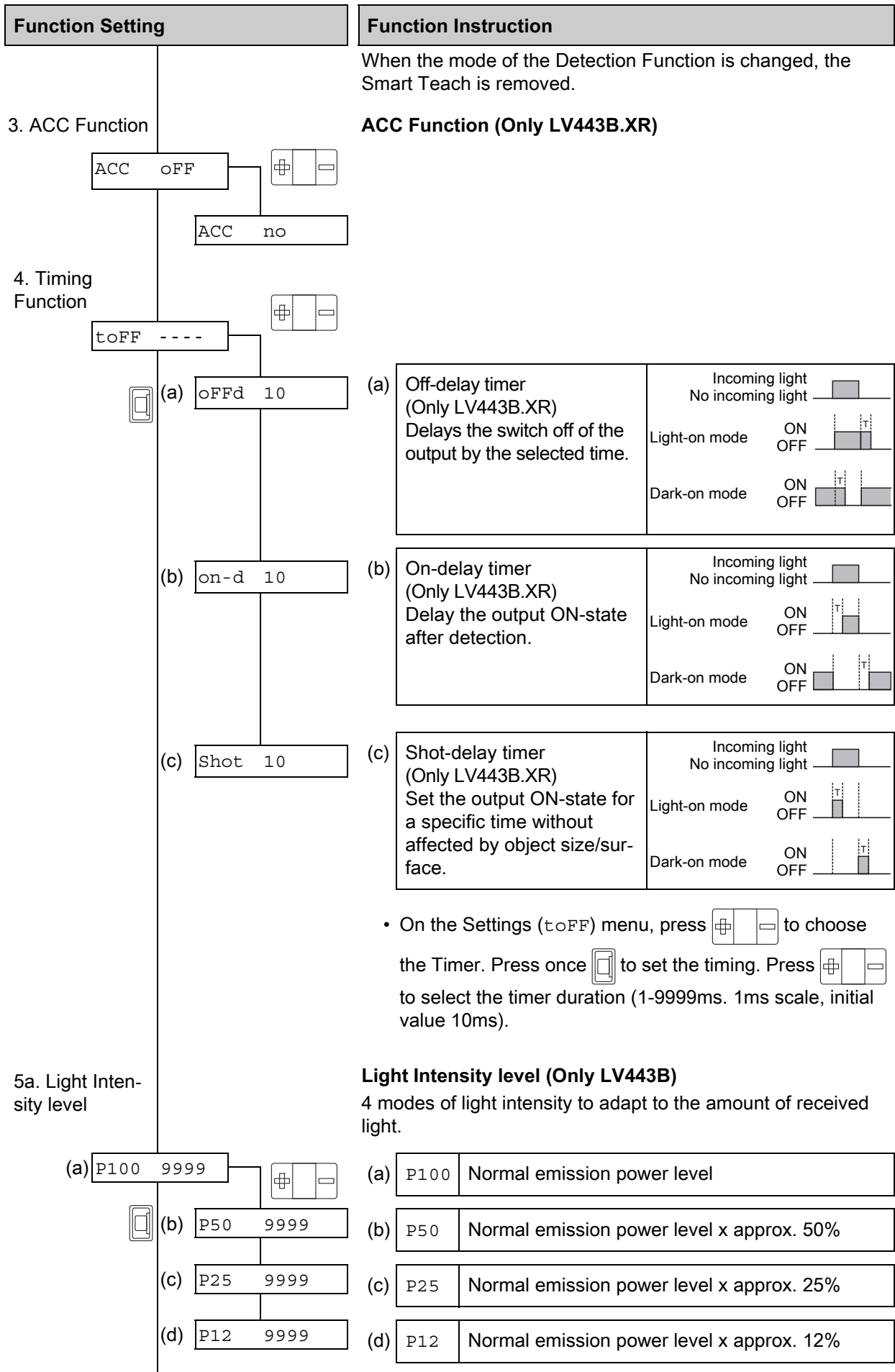



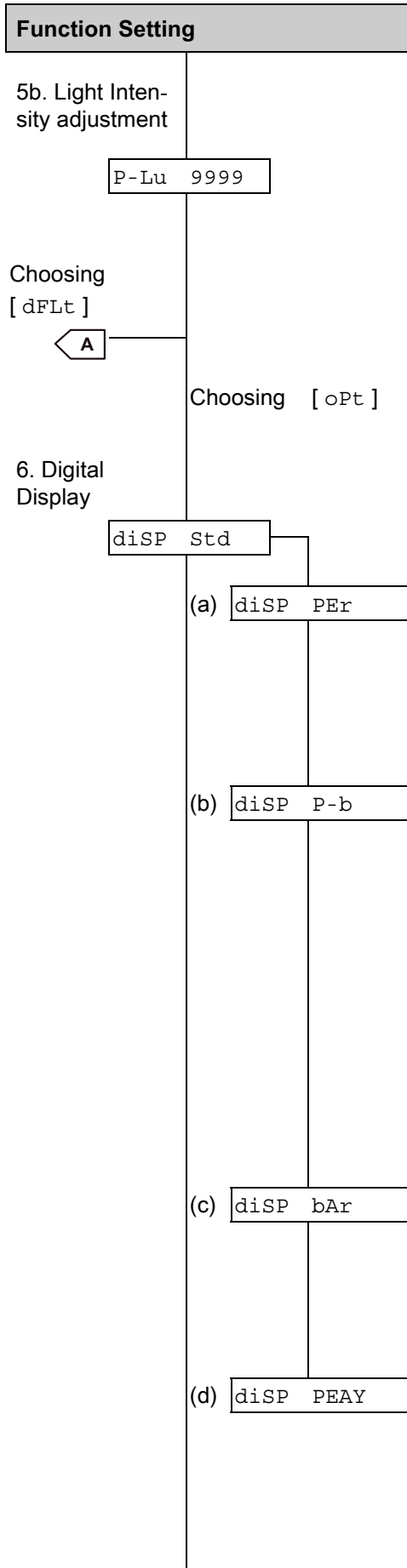



• On the Settings (toFF) menu, press to choose the Timer. Press once to set the timing. Press to select the timer duration (1-9999ms. 1ms scale, initial value 10ms).



Function Instruction

Light Intensity adjustment (Only LV443B.XR)

- Modify the maximum value of the amount of light received (Light Intensity adjustment) through   to set the light intensity (from 100 to 9999, initial value 9999. Press   to select steps of 1. Press and hold  or  for more than 3 seconds to proceed in steps of 10. Continue to hold for 2 seconds, adjust by 100). See chapter 4.6 "Settings".

(a) To read the Incoming Light level vs Threshold

Threshold	Light Level Ratio	
2000	150P	The ratio of Incoming Light level to the threshold is displayed in red Digital Display

(b) Set threshold value using tiny or fast moving object (only LV443B.XR)

Peak Light Level	Bottom Light Level	
8000	2000	When detecting small or fast objects, the signal might vary every time depending on: Object position, Speed, Reflection, Vibration. If just taking one peak and one bottom reading, it would not be reliable. This function considers the lowest peak over time and highest bottom over time.

(c) Bar Graph for easy visualization (Only LV443B.XR)

Threshold		
120% 100% 80%		Displays current values with 100% threshold and 80%~120% display range

(d) Optical Axis adjustment (Only LV443B.XR)

Peak Light Level	Light Level	
3500	3000	Capture the Incoming Light level at the peak and display it in green Digital Display

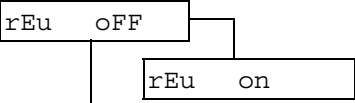
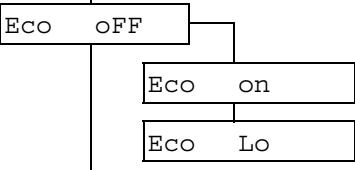
Function Setting	Function Instruction
<p>7. Reverse Display</p> 	<p>Reverse Display (Only LV443B.XR) Amplifier is mounted in a reverse orientation.</p> <ul style="list-style-type: none"> • Reverse Display The threshold value is shown on red Digital Display and the incoming light is shown in green Digital Display.
<p>8. Power Saving</p> 	<p>ECO Mode for Power Saving</p> <ul style="list-style-type: none"> • Low Eco on When operation button is not pressed, Digital Display and indicators will turn off totally after 25 seconds. • Low Eco Lo (Only LV443B.XR) When operation button is not pressed, Digital Display and indicators will be dimmed after 25 seconds.

4.8 Installation of Fiber Optic Sensors

4.8.1 Install to DIN Rail

1. Insert the fiber optic amplifier into the slot on the side of the rail and push onto the rail until you hear the click.

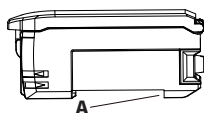

A DIN rail slot side of fiber optic amplifier

4.8.2 Remove From DIN Rail

1. Push the unit in direction ① .
2. Lift up in the direction ② .

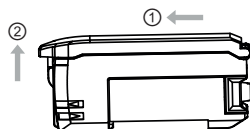

4.8.3 Fiber Optic Cutter

- Use a fiber cutter. Insert the fiber optic unit into the cutter hole to the position to cut off.
- Press the blade down in a single stroke to cut the fiber optic.

4.8.4 Install Fiber Optic

1. Open the cover.

2. Lift up the lock lever.
3. Insert the fiber firmly into the inlet fully until it reaches the end completely.
4. Press the lock lever back to the original position to secure the optical fiber.

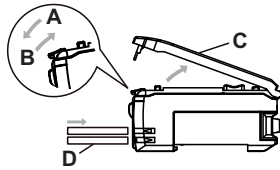

- A** Push to lock lever
- B** Push to unlock lever
- C** Protection cover
- D** Optical fiber

NOTE



When installing a fiber cable into the inlet, make sure the single optical fiber unit is inserted into the upper side of the mounting hole (Transmitter) and the multi-core optical fiber to the lower side (Receiver). This is important for coaxial fibers.

5 Error Indication

Error Name	Reason	Strategy
ACC Error	Incoming Light level decrease because of dust or dirt.	Wipe the fiber optic unit to remove dust resided on the surface. Perform Smart Teach (ST) to restore the Incoming Light level, see chapter 4.6.1 "Light Intensity Adjustment (Only LV443B.XR)"
EEPROM Error	Read / write internal data failed	Reconnect the power. If not restored, perform initialization operation, see chapter 4.6.3 "Setting Initialization"
Current Over	Control overload current of output	Confirm the load of the control output and set it in the rated range. Please confirm if the load is short circuit, see chapter 3.3.1 "Input-Output Circuit Diagram"

6 Maintenance (Troubleshooting)

Fault	Reason	Strategy
Blank on screen	The state of power off, or disconnected	Check wiring, power supply voltage, and power supply capacity, see chapter 3.3.1 "Input-Output Circuit Diagram".
Nothing is displayed on the Digital Display	Power saving is ON state	Turn off the ECO Mode function, see chapter 4.7 "Detail Setting".
Cannot be checked or detected even if the threshold value is minimum	The Detection Function has been set to a small Incoming Light level due to dust or dirt.	When set to LR mode, the Incoming Light level increases and the amount of light displayed increases, see chapter 4.7 "Detail Setting".
Incoming light display variation	Affected by dust or dirt and temperature changing	If you use the ACC Function, the Incoming Light level display can be stabilized, see chapter 4.6 "Settings".
Output indicator blinking	Be affected by mutual interference, etc.	Confirm the connection status of the sensor and power it up again, see chapter 3.3.1 "Input-Output Circuit Diagram".
The amount of light is displayed as-(negative)	Zero reset is open state	Disable the return to zero, see chapter 4.6 "Settings".
Set unknown		Perform the set initialization operation, see chapter 4.6.3 "Setting Initialization"

7 Service and Support

Service Hotline

You can find the contact information for the hotline in your country on our website www.leuze.com under **Contact and support**.

Repair Service and Returns

Defective devices are repaired in our service centers competently and quickly. We offer you an extensive service packet to keep any system downtimes to a minimum. Our service center requires the following information:

- Your customer number
- Product description or part description
- Serial number or batch number
- Reason for requesting support together with a description

Please register the merchandise concerned. Simply register return of the merchandise on our website www.leuze.com under **Contact and support > Repair service and returns**.

To ensure quick and easy processing of your request, we will send you a returns order with the returns address in digital form.