

Translation of original operating instructions

## AMS 148i

Optical laser measurement system – PROFINET



© 2026

Leuze electronic GmbH + Co. KG

In der Braike 1

73277 Owen / Germany

Phone: +49 7021 573-0

Fax: +49 7021 573-199

[www.leuze.com](http://www.leuze.com)

[info@leuze.com](mailto:info@leuze.com)

<b>1</b>	<b>About this document .....</b>	<b>6</b>
<b>2</b>	<b>Safety .....</b>	<b>8</b>
2.1	Intended use .....	8
2.2	Foreseeable misuse.....	8
2.3	Competent persons.....	9
2.4	Disclaimer .....	9
2.5	Laser safety notices .....	10
2.6	Cybersecurity .....	12
<b>3</b>	<b>Fast commissioning .....</b>	<b>13</b>
3.1	Mounting .....	13
3.2	Connecting voltage supply.....	13
3.3	Display .....	13
3.4	PROFINET interface .....	13
3.4.1	Starting up the AMS 148i.....	14
<b>4</b>	<b>Device description .....</b>	<b>15</b>
4.1	Operating principle.....	15
4.2	Indicators and operational controls .....	15
4.2.1	LED status indicators.....	15
4.2.2	Display.....	16
4.2.3	Control buttons .....	17
4.3	Menus .....	17
4.3.1	Menu structure.....	17
4.3.2	Device information menu.....	18
4.3.3	Parameter menu.....	18
4.3.4	Language selection menu .....	22
4.3.5	Diagnosis menu.....	23
4.3.6	Operation examples .....	23
4.4	Reflectors .....	25
4.4.1	Description of the reflective tape .....	25
4.4.2	Overview of reflective tapes .....	25
4.4.3	Selecting reflector size .....	25
<b>5</b>	<b>Mounting.....</b>	<b>27</b>
5.1	Transport and storage.....	27
5.2	Mounting the device.....	28
5.2.1	Mounting with pre-mounted alignment unit (BTA).....	28
5.2.2	Mounting with adapter plate (BT) .....	29
5.2.3	Mounting without accessories .....	29
5.2.4	Parallel mounting.....	30
5.2.5	Parallel mounting of and DDLS optical data transmission .....	32
5.2.6	Mounting with laser beam deflector units .....	32
5.3	Mounting the reflector .....	33
5.3.1	Pitch of the reflector.....	33
<b>6</b>	<b>Electrical connection.....</b>	<b>36</b>
6.1	PWR – voltage supply / switching input/output.....	36
6.2	PROFINET .....	37
6.3	Service .....	37



<b>7</b>	<b>Starting up – PROFINET interface .....</b>	<b>38</b>
7.1	Basic configuration .....	38
7.1.1	PROFINET - communication profile .....	38
7.1.2	Conformance Classes .....	39
7.1.3	Identification and Maintenance functions .....	39
7.2	Topologies .....	40
7.2.1	Star topology .....	40
7.2.2	Linear topology .....	40
7.3	Cable lengths and shielding .....	40
7.4	Starting the device .....	41
7.5	Configuring for the Siemens SIMATIC-S7 control .....	41
7.6	PROFINET project modules .....	43
7.7	Overview of the modules .....	44
7.8	Module M1 – Position value .....	45
7.9	Module M2: Static preset .....	47
7.10	Module M3: I/O 1 Input / Output .....	48
7.11	Module M4: I/O 2 Input / Output .....	51
7.12	Module M5: Status and control .....	54
7.13	Module M6 – Position limit value range 1 .....	56
7.14	Module M7 – Position limit value range 2 .....	57
7.15	Module M8: Error handling procedures .....	58
7.16	Module M9: Velocity .....	60
7.17	Module M10: Velocity limit value 1 .....	61
7.18	Module M11: Velocity limit value 2 .....	63
7.19	Module M12: Velocity status .....	65
7.20	Module M13: Miscellaneous .....	67
7.21	Module M14: Condition monitoring .....	68
<b>8</b>	<b>Starting up the device – webConfig tool .....</b>	<b>69</b>
8.1	System requirements .....	69
8.2	Start webConfig tool .....	70
8.3	Short description of the webConfig tool .....	70
8.3.1	Switching operating mode .....	70
8.3.2	Menu overview .....	71
<b>9</b>	<b>Care, maintenance and disposal .....</b>	<b>72</b>
<b>10</b>	<b>Diagnostics and troubleshooting .....</b>	<b>73</b>
10.1	Status messages .....	73
10.2	LED indicators .....	73
10.3	Display messages .....	74
<b>11</b>	<b>Service and support .....</b>	<b>75</b>
<b>12</b>	<b>Technical data .....</b>	<b>76</b>
12.1	Optical laser measurement system .....	76
12.2	Reflective tapes .....	78
12.2.1	Self-adhesive reflective tape .....	78
12.2.2	Reflective tape on carrier plate .....	78
12.2.3	Reflective tape with heating .....	78
12.3	Dimensioned drawings .....	79

<b>13</b>	<b>Order guide and accessories</b> .....	<b>86</b>
13.1	Part number code .....	86
13.2	AMS 148i type overview .....	87
13.3	Accessories – Mounting .....	87
13.4	Accessories – Reflective tapes .....	88
13.5	Accessories – connection technology .....	88
<b>14</b>	<b>EC Declaration of Conformity</b> .....	<b>89</b>
<b>15</b>	<b>Licenses</b> .....	<b>90</b>



# 1 About this document

## Used symbols and signal words

Tab. 1.1: Warning symbols and signal words

	Symbol indicating dangers to persons
	Symbol indicating dangers from harmful laser radiation
	Symbol indicating possible property damage
<b>NOTE</b>	Signal word for property damage Indicates dangers that may result in property damage if the measures for danger avoidance are not followed.
<b>CAUTION</b>	Signal word for minor injuries Indicates dangers that may result in minor injury if the measures for danger avoidance are not followed.
<b>WARNING</b>	Signal word for serious injury Indicates dangers that may result in severe or fatal injury if the measures for danger avoidance are not followed.

Tab. 1.2: Other symbols

	Symbol for tips Text passages with this symbol provide you with further information.
	Symbol for action steps Text passages with this symbol instruct you to perform actions.
	Symbol for action results Text passages with this symbol describe the result of the preceding action.

Tab. 1.3: Terms and abbreviations

CFR	Code of Federal Regulations
DCP	Discovery and Configuration Protocol
EMC	Electromagnetic compatibility
FE	Functional earth
FW	Firmware
GSD	General Station Description
GSDML	Generic Station Description Markup Language
HW	Hardware
IO or I/O	Input/Output
IOPS	Input/output commands per second
I&M	Identification & Maintenance
IP	Internet Protocol
LED	Light emitting diode

MAC	Media Access Control
NEC	National Electric Code
NTP	Network Time Protocol
OLED	Organic light-emitting diode (OLED)
PELV	Protective Extra-Low Voltage
RT	Real Time
SNMP	Simple Network Management Protocol
PLC	Programmable Logic Controller
SW	Software
TCP	Transmission Control Protocol
UDP	User Datagram Protocol
USB	Universal Serial Bus
UL	Underwriters Laboratories
XML	Extensible Markup Language

## 2 Safety

This sensor was developed, manufactured and tested in line with the applicable safety standards. It corresponds to the state of the art.





### 2.1 Intended use

The AMS 100i optical laser measurement system is an absolute measuring optical laser measurement system for distance measurement up to 200 m against a reflector.

#### Areas of application

The AMS 100i is designed for the following areas of application:

- Positioning of automated, moving plant components
- Travel and lifting axes of stacker cranes
- Repositioning units
- Gantry crane bridges and their trolleys
- Elevators
- Electroplating plants

	<b>CAUTION</b>
	<p><b>Observe intended use!</b></p> <p>The protection of personnel and the device cannot be guaranteed if the device is operated in a manner not complying with its intended use.</p> <ul style="list-style-type: none"> <li>↳ Only operate the device in accordance with its intended use.</li> <li>↳ Leuze electronic GmbH + Co. KG is not liable for damages caused by improper use.</li> <li>↳ Read these operating instructions before commissioning the device. Knowledge of the operating instructions is an element of proper use.</li> </ul>
	<b>CAUTION</b>
	<p><b>UL applications!</b></p> <p>For UL applications, the device must be powered by a PS2 in accordance with EN / IEC / UL 62368-1 or an LPS in accordance with EN / IEC / UL 60950-1 or NEC Class 2.</p>
<b>NOTICE</b>	
	<p><b>Comply with conditions and regulations!</b></p> <ul style="list-style-type: none"> <li>↳ Observe the locally applicable legal regulations and the rules of the employer's liability insurance association.</li> </ul>

### 2.2 Foreseeable misuse

Any use other than that defined under "Intended use" or which goes beyond that use is considered improper use.

In particular, use of the device is not permitted in the following cases:

- in rooms with explosive atmospheres
- in circuits which are relevant to safety
- for medical purposes

**NOTICE****Do not modify or otherwise interfere with the device!**

- ↪ Do not carry out modifications or otherwise interfere with the device. The device must not be tampered with and must not be changed in any way.
- ↪ The device must not be opened. There are no user-serviceable parts inside. Opening the device voids the warranty. Warranted features cannot be guaranteed after the device has been opened.
- ↪ Repairs must only be performed by Leuze electronic GmbH + Co. KG.

### 2.3 Competent persons

Connection, mounting, commissioning and adjustment of the device must only be carried out by competent persons.

Prerequisites for competent persons:

- They have a suitable technical education.
- They are familiar with the rules and regulations for occupational safety and safety at work.
- They are familiar with the operating instructions for the device.
- They have been instructed by the responsible person on the mounting and operation of the device.

#### **Certified electricians**

Electrical work must be carried out by a certified electrician.

Due to their technical training, knowledge and experience as well as their familiarity with relevant standards and regulations, certified electricians are able to perform work on electrical systems and independently detect possible dangers.



In Germany, certified electricians must fulfill the requirements of accident-prevention regulations DGUV (German Social Accident Insurance) provision 3 (e.g. electrician foreman). In other countries, there are respective regulations that must be observed.

### 2.4 Disclaimer

Leuze electronic GmbH + Co. KG is not liable in the following cases:

- The device is not being used properly.
- Reasonably foreseeable misuse is not taken into account.
- Mounting and electrical connection are not properly performed.
- Changes (e.g., constructional) are made to the device.

2.5 Laser safety notices

 <b>ATTENTION</b>	
	<p><b>LASER RADIATION – CLASS 2 LASER PRODUCT</b></p> <p><b>Do not stare into beam!</b></p> <p>The device satisfies the requirements of IEC/EN 60825-1:2014 safety regulations for a product of <b>laser class 2</b> and complies with 21 CFR 1040.10 except for conformance with IEC 60825-1 Ed. 3., as described in Laser Notice No. 56, dated May 8, 2019.</p> <ul style="list-style-type: none"> <li>↪ Never look directly into the laser beam or in the direction of reflected laser beams! If you look into the beam path over a longer time period, there is a risk of injury to the retina.</li> <li>↪ Do not point the laser beam of the device at persons!</li> <li>↪ Interrupt the laser beam using a non-transparent, non-reflective object if the laser beam is accidentally directed towards a person.</li> <li>↪ When mounting and aligning the device, avoid reflections of the laser beam off reflective surfaces!</li> <li>↪ <b>CAUTION!</b> Use of controls or adjustments or performance of procedures other than specified herein may result in hazardous light exposure.</li> <li>↪ Observe the applicable statutory and local laser protection regulations.</li> <li>↪ The device must not be tampered with and must not be changed in any way. There are no user-serviceable parts inside the device. Repairs must only be performed by Leuze electronic GmbH + Co. KG.</li> </ul>

<b>NOTICE</b>	
	<p><b>Affix laser information and warning signs!</b></p> <p>Laser information and warning signs attached to the device. Also included with the device are self-adhesive laser warning and laser information signs (stick-on labels) in multiple languages.</p> <ul style="list-style-type: none"> <li>↪ Affix the laser information sheet to the device in the language appropriate for the place of use. When using the device in the US, use the stick-on label with the "Complies with 21 CFR 1040.10" notice.</li> <li>↪ Affix the laser information and warning signs near the device if no signs are attached to the device (e.g. because the device is too small) or if the attached laser information and warning signs are concealed due to the installation position. Affix the laser information and warning signs so that they are legible without exposing the reader to the laser radiation of the device or other optical radiation.</li> </ul>



- 1 Laser aperture
- 2 Laser warning sign
- 3 Laser information sign with laser parameters

Fig. 2.1: Laser aperture, laser warning signs



Fig. 2.2: Laser warning and information signs – supplied stick-on labels

## 2.6 Cybersecurity

Guarding against cybersecurity threats requires the operating company to have a comprehensive cybersecurity concept, which must be continuously reviewed and maintained. A suitable concept consists of organizational, technical, procedural, electronic and physical defense levels and takes into account appropriate measures for the different types of risk. The measures implemented in this product can only help guard against cybersecurity threats if the product is used as part of such a concept.

### Physical access control

The operating company must ensure that physical access to the absolute measuring system is restricted exclusively to authorized personnel.

### Network segmentation

The absolute measurement system should only be operated on a network that is protected against unauthorized access. The operating company's network should therefore be segmented into different zones. Each environment has a subnet. Internal communication is only permitted on the basis of a predefined network policy based on an approval list. Information on the correct zoning of industrial automation networks can be found, for example, in the IEC 62443 series of standards.

### Activating access protection for the webConfig tool

When using the webConfig tool's web-based user interface, it should be protected against unauthorized access by means of a user role to prevent unintentional or accidental misuse. For further information, see chapter 8.3 "Short description of the webConfig tool".

### Network services

The device uses several network services for operation. Information on the factory default settings when using the device can be found in the following table.

Tab. 2.1: Standard device settings for the network services

Service / Protocol	Physical connection	Port	Encrypted	Default status	Description
WebConfig tool	XF1 IN XF2 OUT XF0 Service	80	No	Activated	Diagnosis and firmware update
PROFINET	XF1 IN XF2 OUT	Various	No	Activated	Configuration and data exchange
Telnet server	XF0 Service	23 / TCP	No	Activated	Device diagnosis

### 3 Fast commissioning

Below you will find a short description for the initial commissioning of the AMS 100i. Detailed explanations for all listed points can be found throughout these operating instructions.

#### 3.1 Mounting

Depending on the purchased model, the AMS 100i can be mounted in various ways (see chapter 13 "Order guide and accessories"):

- with pre-mounted alignment unit (BTA)
- with adapter plate (BT)
- with the threaded holes in the housing (without accessories)

The AMS 100i and the corresponding reflector are mounted on two mutually opposing, plane-parallel, flat walls or system parts. For error-free position measurement, there must be an unobstructed line-of-sight between the AMS 100i and the reflector.

##### Mounting the device

Mounting with pre-mounted alignment unit (BTA):

- ↳ Secure the alignment unit together with mounted laser using four M5 screws.
- ↳ Align the laser using the two adjustment screws on the alignment unit. Adjust so that the laser light spot is positioned at the center of the reflector.

If the sensor was purchased without pre-mounted alignment unit (BTA),

- ↳ first mount either the adapter plate (BT) or one of the accessory parts to the sensor or
- ↳ secure the sensor directly using the threaded holes provided in the housing.

For further information, see chapter 5.2 "Mounting the device".

##### Mounting the reflector

- ↳ Secure the reflector with four M5 screws.
- ↳ Tilt the reflector by approx. 1° using the enclosed spacer sleeves.

For further information, see chapter 5.3 "Mounting the reflector".

#### 3.2 Connecting voltage supply

- ↳ Connect the AMS100i via the M12 connection XD1 PWR.

For further information, see chapter 6 "Electrical connection".

#### 3.3 Display

Once the laser measurement system is supplied with voltage, the device status as well as the measured position values can be read on the display. The display automatically switches to the display of the measurement values.

Navigate using the [DOWN]/[ENTER] buttons to read off and change the data and parameters.

For further information, see chapter 4.2.2 "Display".

#### 3.4 PROFINET interface

- ↳ Install the GSDML file associated with the AMS 148i in the PROFINET Manager of your control. Activate the desired modules (at least one module).

The network address for PROFINET is assigned via the PROFINET Manager.

##### Standalone operation in PROFINET network

During standalone operation of the AMS 148i, the PROFINET network is connected to BUS IN.

BUS OUT requires no terminating resistor.

##### Network mode in PROFINET network

In network mode the AMS 148i is connected to PROFINET via BUS IN. Further PROFINET participants can be connected to the integrated switch of the AMS 148i via the BUS OUT connection.

### 3.4.1 Starting up the AMS 148i

The procedures described below are for the configuration of an AMS 148i with a Siemens *Simatic* S7 PLC.

- ↳ Switching on the supply voltage
  - ⇒ The AMS 148i displays the “Status and measurement data” main menu.
- ↳ Installation of the corresponding GSD file in the Simatic Hardware Manager.
- ↳ Projection of the PROFINET network including the AMS 148i GSD file. Definition of the IP addresses, sub-network mask and definition of a device name assigned to the IP address.
- ↳ Download of the project to the connected Siemens control.

Further information on commissioning, see chapter 7.5 "Configuring for the Siemens SIMATIC-S7 control", or the individual commissioning steps see chapter 7 "Starting up – PROFINET interface".

## 4 Device description

### 4.1 Operating principle

The AMS 100i optical laser measurement system calculates distances to fixed as well as moving system parts. The distance to be measured is calculated according to the principle of the propagation time of radiated light. Here, the light emitted by the laser diode is reflected by a reflector onto the receiving element of the laser measurement system. The AMS 100i calculates the distance to the reflector based on the "propagation time" of the light using a technique known as phase-correlated time-of-flight measurement. The high absolute measurement accuracy of the laser measurement system and the fast response time are designed for position control applications.

### 4.2 Indicators and operational controls

#### 4.2.1 LED status indicators

##### PWR LED

Tab. 4.1: PWR indicators

Color	State	Description
	Off	Device OFF, no supply voltage
Green	Flashing	<ul style="list-style-type: none"> <li>No measurement value output</li> <li>Voltage connected</li> <li>Self test running</li> <li>Initialization running</li> <li>Parameter download running</li> <li>Boot process running</li> </ul>
Green	Continuous light	<ul style="list-style-type: none"> <li>Device ok</li> <li>Measurement value output</li> <li>Self test successfully finished</li> <li>Device monitoring active</li> </ul>
Red	Flashing	<ul style="list-style-type: none"> <li>Device OK but warning message (ATT, TMP, LSR) set in display</li> <li>Light beam interruption</li> <li>Plausibility error (PLB)</li> </ul>
Red	Continuous light	<ul style="list-style-type: none"> <li>No measurement value output, details see chapter 10.2 "LED indicators"</li> <li>The device is booting up (the NET LED also lights up red)</li> </ul>
Orange	Flashing	<ul style="list-style-type: none"> <li>PROFINET wave function</li> </ul>
Orange	Continuous light	<ul style="list-style-type: none"> <li>Parameter enable active</li> <li>No data on the host interface</li> </ul>

##### NET LED

Tab. 4.2: NET indicators

Color	State	Description
	Off	No supply voltage (power)
Green	Continuous light	Connection to and communication with the controller
Green	Flashing	PROFINET interface is being initialized

Color	State	Description
Red	Flashing	<ul style="list-style-type: none"> <li>• Bus error, communication error</li> <li>• Parameterization or configuration failed ("parameter failure")</li> <li>• IO error</li> <li>• No data exchange</li> </ul>
Red	Continuous light	<ul style="list-style-type: none"> <li>• The device is booting up (PWR LED also lights up RED)</li> <li>• Bus error, network error</li> <li>• No communication established to the controller ("no data exchange")</li> </ul>
Orange	Flashing	PROFINET wave function

#### 4.2.2 Display

Status and warning messages are shown in the display only if status changes or faults occur at the device.

Example:



Fig. 4.1: Example of status and warning message

Tab. 4.3: Status and warning messages in the display

Display	Type of message	Meaning
1	Input 1 or output 1 active	Function depending on configuration
2	Input 2 or output 2 active	Function depending on configuration
LSR	Laser pre-failure message warning	Laser diode old, device still functional, exchange or have repaired.
TMP	Temperature monitoring warning	Permissible internal device temperature exceeded / not met
PLB	Plausibility error	Implausible measurement value. Possible cause: <ul style="list-style-type: none"> <li>• Light beam interruption</li> <li>• Measurement range exceeded</li> <li>• Permissible internal device temperature exceeded</li> <li>• Traverse rate &gt; 10 m/s</li> </ul> Depending on the configuration, either zero or the last valid measurement value is output at the interfaces.
ATT	Reception signal warning	Laser exit window or reflector soiled or fogged by rain, water vapor or fog. Clean or dry surfaces.
ERR	Internal hardware error	The device must be sent in for inspection.



#### Position value

The measured position value is displayed in the configured unit of measurement.

- +87.000 m With the metric setting, the measurement value is always displayed in meters to three decimal places.
- +87.0 in With the inch setting, the measurement value is always displayed in inches to one decimal place.

### 4.2.3 Control buttons

Tab. 4.4: Control buttons

	DOWN	Navigate downward/sideways
	ENTER	Confirm/enter value, change menu levels

#### Navigating within the menus

- ↪ Use the [DOWN] button to select the menus within a menu level.
- ↪ Use the [ENTER] button to activate the selected menu item.

When one of the buttons is actuated, the display illumination is activated for 10 minutes.

#### Setting values

If a value can be entered, the display will look like the example below:



Fig. 4.2: Example of value entry

- ↪ Set the desired value using the [DOWN] button. If you have entered an incorrect digit, press the [DOWN] button until the desired digit appears again.
- ↪ Save the set value by pressing the [ENTER] button.
- ↪ With multi-digit numbers, after entering a digit press the [ENTER] button to move to the next digit on the right.

#### Selecting options

If an option can be selected, the display will look like the example below:



Fig. 4.3: Example of option selection

- ↪ Select the desired option using the [DOWN] button.
- ↪ Activate the option by pressing the [ENTER] button.

## 4.3 Menu

<b>NOTICE</b>	
	Terms may be shown in abbreviated form on the display. To improve readability, the terms are written in full below.

### 4.3.1 Menu structure

#### Main menu (Level 1)

- Device information, see chapter 4.3.2 "Device information menu"
- Parameter, see chapter 4.3.3 "Parameter menu"
- Language selection, see chapter 4.3.4 "Language selection menu"
- Diagnosis, see chapter 4.3.5 "Diagnosis menu"

### 4.3.2 Device information menu

Tab. 4.5: Device information menu

Level 1	Level 2	Level 3	Level 4	Level 5
Device information	Product name			
	Part no.			
	Serial No.			
	HW revision			
	FW revision			

### 4.3.3 Parameter menu

Tab. 4.6: Parameter menu

Level 2	Level 3	Level 4	Level 5
Parameter handling	Parameter enable		
	Password	Activate password	
		Password entry	
	Parameters to default		
PROFINET	Activation		
Position value	Unit		
	Counting direction		
	Offset		
	Preset		
	Error delay		
	Position value in the case of failure		
	Filter type		
I/O	I/O 1	Port configuration	
		Switching input	Function
			Activation
		Switching output	Function
			Activation
		I/O 2	Port configuration
	Switching input		Function
			Activation
	Switching output		Function
			Activation
	Limit values		Max. velocity
		Max. velocity	

Level 2	Level 3	Level 4	Level 5
Limit values	Upper position limit 1	Activation	
		Value entry	
	Lower position limit 1	Activation	
		Value entry	
	Upper position limit 2	Activation	
		Value entry	
	Lower position limit 2	Activation	
		Value entry	
	Maximum velocity	Activation	
		Value entry	
Other	Display dimming	10 minutes	
		OFF	
	Heating control (For heater)	Standard (10°C – 15°C)	
		Extended (30°C – 35°C)	
	Service Ethernet IP	IP address	
		Port address	
	NTP server	IP address	

**Parameter handling**

Tab. 4.7: Submenu *Parameter handling*

Level 3	Level 4	Selection/configuration options Description	Standard
Parameter enable		<p><b>Lock and enable parameter entry</b> ON/OFF</p> <p>The standard setting (OFF) prevents unintended parameter changes.</p> <p>With parameter enable activated (ON), the display is inverted. In this state, it is possible to change parameters manually.</p>	OFF
Password	Activate password	<p><b>Set up password</b> ON/OFF</p> <p>To enter a password, parameter enable must be activated.</p> <p>If a password is assigned, changes can only be made after the password is entered.</p> <p>The master password 507 overrides the individually set password.</p>	OFF
	Enter password	<p>Setting a 4-digit numerical password.</p> <p>After confirming the password, the entered password will be censored with “000” for privacy reasons.</p>	
Parameters to default		<p><b>Reset device to default settings</b></p> <p>Pressing the [ENTER] key after selecting the “Parameters to default” menu option resets all parameters to their default settings without any further security prompts.</p> <p>In this case, English is selected as the display language.</p>	

**PROFINET**

Tab. 4.8: Submenu *PROFINET*

Level 3	Selection/configuration options Description	Standard
Activation	Activates or deactivates the AMS 100i as an PROFINET participant.	ON

**Position value**

Tab. 4.9: Submenu *Position value*

Level 3	Selection/configuration options Description	Standard
Unit	Metric/Inch Specifies the units of the measured distances. The set values for preset, offset and velocity value are not automatically converted when the unit is changed. Before changing the unit, check these values and adjust if necessary.	Metric
Counting direction	Positive/Negative Positive: The measurement value begins at 0 and increases with increasing distance. Negative: The measurement value begins at 0 and decreases with increasing distance. Negative distance values may need to be compensated with an offset or preset.	Positive
Offset	Output value = measurement value + offset The resolution of the offset value is independent of the selected "Position resolution" and is entered in mm or in/100. The offset value is effective immediately after entry. If the preset value is activated, this has priority over the offset. Preset and offset are not offset against each other.	Maximum configurable value: ±200,000 mm ±800,000 in/100
Preset	The preset value is accepted by means of teach pulse. The teach pulse can be placed on a hardware input of the M12 PWR connector. The hardware input must be appropriately configured, see chapter 7.1 "Basic configuration", see chapter 7.2 "Topologies".	Maximum configurable value: ±200,000 mm ±800,000 in/100
Error delay	ON/OFF Specifies whether, in the event of an error, the position value immediately outputs the value of the "Position value in the case of failure" parameter or the last valid position value for the configured error delay time.	ON/100 ms
Position value in the case of failure	Last valid value / zero Specifies which position value is output after the error delay time elapses.	Zero
Filter type	Normal/High/Low/AVG comp Choosing the right filter type can improve measurement accuracy at extreme traverse rates (both positive and negative) and reduce measurement value noise. Standard – suitable for use in all areas High – for very high traverse rates Low – for very low traverse rates AVG comp – Compatibility mode	Normal

I/O

Tab. 4.10: Submenu I/O 1 settings

Level 3	Level 4	Level 5	Selection/configuration options Description	Standard
I/O 1	Port configuration		Input/Output Defines whether I/O 1 functions as an output or input.	Output
	Switching input	Function	No function/teach preset/laser ON/OFF	No function
		Activation	Low active/High active	Low active
	Switching output	Function	Pos. Limit 1 / Pos. Limit 2 velocity/intensity (ATT) / Temperature (TMP) / Laser (LSR) / Plausibility (PLB) / Hardware (ERR)  In the case of multiple entries, the individual functions are processed in an OR function.	Plausibility (PLB) Hardware (ERR)
Activation		Low active/High active	Low active	

Tab. 4.11: Submenu I/O 2 settings

Level 3	Level 4	Level 5	Selection/configuration options Description	Standard
I/O 2	Port configuration		Input/Output Defines whether I/O 2 functions as an output or input.	Output
	Switching input	Function	No function/teach preset/laser ON/OFF	No function
		Activation	Low active/High active	Low active
	Switching output	Function	Pos. Limit 1 / Pos. Limit 2 velocity/intensity (ATT) / Temperature (TMP) / Laser (LSR) / Plausibility (PLB) / Hardware (ERR)  In the case of multiple entries, the individual functions are processed in an OR function.	Intensity (ATT) Temperature (TMP) Laser (LSR)
Activation		Low active/High active	Low active	

Tab. 4.12: Submenu *Limit values*

Level 3	Level 4	Level 5	Selection/configuration options Description	Standard
Limit values	Upper pos. limit 1	Activation	ON / OFF	OFF
		Value entry	Adjustable value: ± xxxxxx [mm]	
	Lower pos. limit 1	Activation	ON / OFF	OFF
		Value entry	Adjustable value: ± xxxxxx [mm]	
	Upper pos. limit 2	Activation	ON / OFF	OFF
		Value entry	Adjustable value: ± xxxxxx [mm]	
	Lower pos. limit 2	Activation	ON / OFF	OFF
		Value entry	Adjustable value: ± xxxxxx [mm]	
Max. velocity	Activation	ON / OFF	OFF	
	Max. velocity	Max. configurable value: 15,000 mm/s (60,000 in/100s)		

**Other**

Level 3	Level 4	Selection/configuration options Description	Standard
Display dimming		10 minutes/ON The display illumination is dimmed after 5 minutes and switched off after 10 minutes. If the <i>OFF</i> parameter is selected, dimming is permanently deactivated, i.e. the measurement value is always displayed.	10 min
Heating control (For heaters)	Standard (10°C – 15°C)	Defines a switch-on/off range for the heating.	Standard
	Extended (30°C – 35°C)	Extends the switch-on/off range of the heating.	
Service Ethernet IP	IP address	The service interface is available for Leuze-internal purposes only.	192.168.60.101
	Port address	The service interface is available for Leuze-internal purposes only.	7070
NTP server	IP address	Using this IP address, the AMS clock can be synchronized with the network.	Customizable, default IP address 0.0.0.0

**4.3.4 Language selection menu**

The AMS 100i is delivered from the factory with the display preset to English.

5 display languages are available:

- German
- English
- Spanish
- French
- Italian

To change the language, no password needs to be entered and parameter enable does not need to be activated. The display language is a passive operational control and not a function parameter.

4.3.5 Diagnosis menu

A detailed description of the individual functions can be found in see chapter 10 "Diagnostics and troubleshooting".

4.3.6 Operation examples

Structure of menu items in display



Two menu lines, one on top of the other, are always shown in the display.

<b>Device information</b>				
<b>Network information</b>				
Status and measurement data				
Parameter	Parameter handling	Parameter enable		
Language selection		Password	Activate password	...
Service		Parameters to default	Password entry	...

Parameter enable

During normal operation parameters can be viewed only. If you want to change any parameters, you must select the menu item *ON* in the menu **Parameters > Parameter handling > Parameter enable** . To do this, proceed as follows.

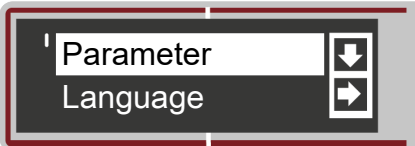
Tab. 4.13: Operating example for "parameter enable"

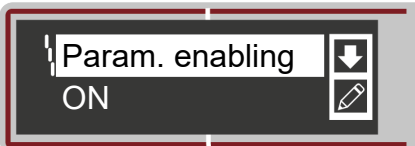
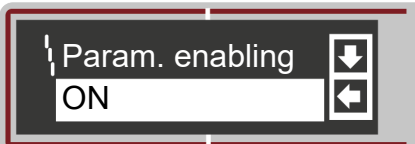
	In the main menu, use the [DOWN] button to select the menu item <i>Parameter</i> .
	Press the [ENTER] key to access the menu <i>Parameter</i> .
	Use the [DOWN] button to select the menu item <i>Parameter handling</i> .
	Press the [ENTER] key to access the menu <i>Parameter handling</i> .
	In the <i>Parameter handling</i> menu, use the [DOWN] button to select the menu item <i>Parameter enable</i> .
	Press the [ENTER] key to access the menu <i>Parameter enable</i> .
	In the <i>Parameter enable</i> menu, use the [DOWN] button to select the menu item <i>ON</i> .
	Press the [ENTER] button to activate parameter enable.

**NOTICE**

 As long as parameter enable is active, the entire AMS 100i display is inverted. If a password was stored, parameter enable is not possible until this password is entered; see the example below.

As long as parameter enable is active, communication between control and AMS 148i is interrupted. The extended networking via BUS OUT is retained.

Parameters set via the display when operating the AMS 148i on the PROFINET are overwritten by the parameters set in the GSD modules.







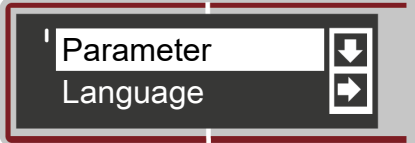

Changes to the PROFINET parameters via display entry have immediate effect.

**Password for parameter enable**

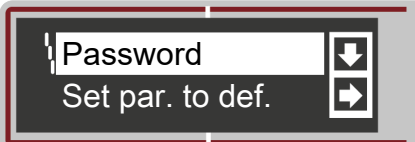
Parameter entry on the AMS 100i can be protected with a password.

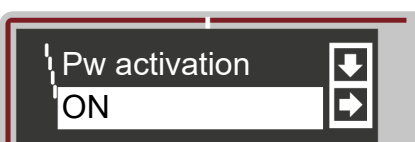
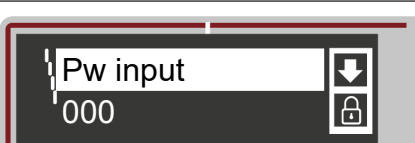
If a password is assigned, parameter enable must be activated using the password. If parameter enable has been activated after successfully entering the password, parameters can be changed via the display.

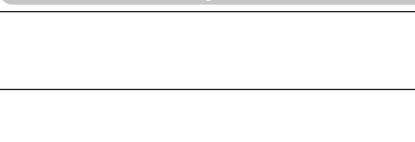
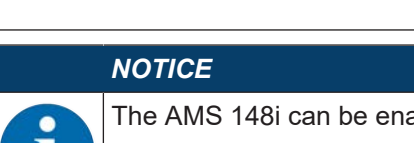
Tab. 4.14: Operating example for "password for parameter enable"

	<p>In the main menu, use the [DOWN] button to select the menu item <i>Parameter</i> .</p>
	<p>Press the [ENTER] key to access the menu <i>Parameter</i> .</p>
	<p>Use the [DOWN] button to select the menu item <i>Parameter handling</i> .</p>
	<p>Press the [ENTER] key to access the menu <i>Parameter handling</i> .</p>
	<p>In the <i>Parameter handling</i> menu, use the [DOWN] button to select the menu item <i>Password</i> .</p>
	<p>Press the [ENTER] key to access the menu <i>Password</i> .</p>
	<p>In the <i>Password</i> menu, use the [DOWN] button to select the menu item <i>Activate password</i> .</p>
	<p>Press the [ENTER] key to access the menu Password activation.</p>
	<p>In the <i>Activate password</i> menu, use the [DOWN] button to select the menu item <i>OFF</i> .</p>
	<p>Press the [ENTER] button to set password activation to <i>ON</i> .</p>
	<p>In the <i>Password</i> menu, use the [DOWN] button to select the menu item <i>Password entry</i> .</p>
	<p>Press the [ENTER] key to access the menu <i>Password entry</i> .</p>
	<p>Now enter the password (digits), <b>see chapter 4.2.3 "Control buttons"</b> .</p>
	<p>Press the [ENTER] button to confirm the value input.</p>
	<p>Exit the menu by pressing the [DOWN] button or wait until the AMS displays the measurement screen again.</p>
	<p>The next time you try to make a selection using the control buttons, you will now be prompted to enter the password to allow you to make entries.</p>

<b>NOTICE</b>	
	<p>The AMS 148i can be enabled at any time using the master password 507.</p>

## 4.4 Reflectors

### 4.4.1 Description of the reflective tape

The AMS 100i measures distances against a reflective tape specified by Leuze. All technical data given for the AMS 100i, such as the operating range or accuracy, can only be achieved with the reflective tape specified by Leuze.

The reflective tape consists of a white, microprism-based reflective material. The microprisms are protected by a hard, highly transparent protective layer.

Under certain circumstances, the protective layer can cause surface reflections. The surface reflections can be directed past the AMS 100i by positioning the reflective tape at a slight incline. How to mount the reflective tape/reflectors is described in these operating instructions (see chapter 5.3 "Mounting the reflector").

A commercially available household detergent can be used for cleaning. Rinse with clear water and dry the surface. Do not use any abrasive agents.

Store reflective tapes in a cool and dry place.

### 4.4.2 Overview of reflective tapes

The reflective tapes/reflectors must be ordered separately, see chapter 13.4 "Accessories – Reflective tapes".

- Self-adhesive reflective tape
  - The reflective tape (...x...-**S**) must be bonded to a separate carrier plate (not included in the scope of delivery).
  - Technical data: see chapter 12.2.1 "Self-adhesive reflective tape"
- Reflective tape on carrier plate
  - The reflective tape (...x...-**M**) is affixed to a carrier plate.
  - Technical data: see chapter 12.2.2 "Reflective tape on carrier plate"
- Reflective tape with heating
  - The reflective tape (...x...-**H**) is affixed to a heated, thermally insulated carrier. The insulation results in a very high energetic efficiency. Only the reflective tape is kept at the specified temperature by the integrated heater. The insulation on the back prevents the generated heat from being dissipated via the steel construction. Energy costs are greatly reduced in the case of continuous heating.
  - Technical data: see chapter 12.2.3 "Reflective tape with heating"

### 4.4.3 Selecting reflector size

Depending on the system dimensions, the reflector can be mounted so that it moves with the vehicle or it can be mounted at a fixed location.

The choice of size is left to the user. In each case, the user must check whether the recommended reflector size is suitable for the respective application.

Tab. 4.15: Recommended reflector size

Device type	Operating range [m]	Recommended reflector size (H x W)	Type of reflective tape ...- <b>S</b> (self-adhesive) ...- <b>M</b> (carrier plate) ...- <b>H</b> (heating)	Part no.
AMS 148i 40	40	200x200 mm	REF 4-A-150x150 <sup>1</sup>	50141015
			Reflective tape 200x200-S	50104361
			Reflective tape 200x200-M	50104364
			Reflective tape 200x200-H	50115020
			REF 4-A-300x300 <sup>1</sup>	50141014
AMS 148i 120	120	500x500 mm	Reflective tape 500x500-S	50104362
			Reflective tape 500x500-M	50104365
			Reflective tape 500x500-H	50115021

Device type	Operating range [m]	Recommended reflector size (H x W)	Type of reflective tape ...-S (self-adhesive) ...-M (carrier plate) ...-H (heating)	Part no.
AMS 148i 200	200	749 x 914 mm	Reflective tape 749x914 – S	50104363
		914x914 mm	Reflective tape 914x914 – M	50104366
			Reflective tape 914x914 – S	50108988
			Reflective tape 914x914 – H	50115022

<sup>1</sup> For landside mounting

<b>NOTICE</b>	
	<p>The recommended reflector sizes apply to on-vehicle mounting of the AMS 100i. For stationary mounting of the AMS 100i, a smaller reflector is generally sufficient for all measurement distances. For this reason, two smaller reflector sizes are available in the self-adhesive model "-S", see chapter 13.4 "Accessories – Reflective tapes".</p> <p>During system planning and design, always check whether mechanical travel tolerances require the use of a reflector larger than that which is recommended. This applies, in particular, when the laser measurement system is mounted on a vehicle. During travel, the laser beam must reach the reflector unobstructed. For on-vehicle mounting of the AMS 100i, the reflector size must accommodate any travel tolerances that may arise and the associated "wandering" of the light spot on the reflector.</p>

## 5 Mounting

### 5.1 Transport and storage

<b>NOTICE</b>	
	<ul style="list-style-type: none"> <li>↪ Package the device for transport and storage in such a way that is protected against shock and humidity. Optimum protection is achieved when using the original packaging.</li> <li>↪ Ensure compliance with the approved environmental conditions listed in the specifications.</li> </ul>

#### Unpacking

- ↪ Check the packaging content for any damage. If damage is found, notify the post office or shipping agent as well as the supplier.
- ↪ Check the delivery contents using your order and the delivery papers:
  - Delivered quantity
  - Device type and model as indicated on the name plate
  - Package insert

The name plate provides information as to what AMS 100i type your device is, see chapter 13.2 "AMS 148i type overview".













NEC class 2 / LPS  
Factory-ID: LEO

## Leuze

Leuze electronic GmbH + Co. KG 

D-73277 Owen In der Braike 1 [www.leuze.com](http://www.leuze.com)

Made in Germany

### AMS 148i 200 BTA

**Part-No. 50155737**

Serial-No. 01234567890

Manufactured FEB 2026

Software V2.0.0

Supply 18-30V DC max.250mA

operation temperature -5°C...+60°C

MAC 00:15:7b:1a:11:22

Fig. 5.1: AMS 148i name plate

- ↪ Save the original packaging for later storage or shipping.
- ↪ If you have questions, please contact your supplier or Leuze customer service.
- ↪ Observe the applicable local regulations when disposing of the packaging materials.

## 5.2 Mounting the device

The AMS 100i and the corresponding reflector are mounted on two mutually opposing, plane-parallel, flat walls or system parts. For error-free position measurement, there must be an unobstructed line-of-sight between the AMS 100i and the reflector.

### 5.2.1 Mounting with pre-mounted alignment unit (BTA)

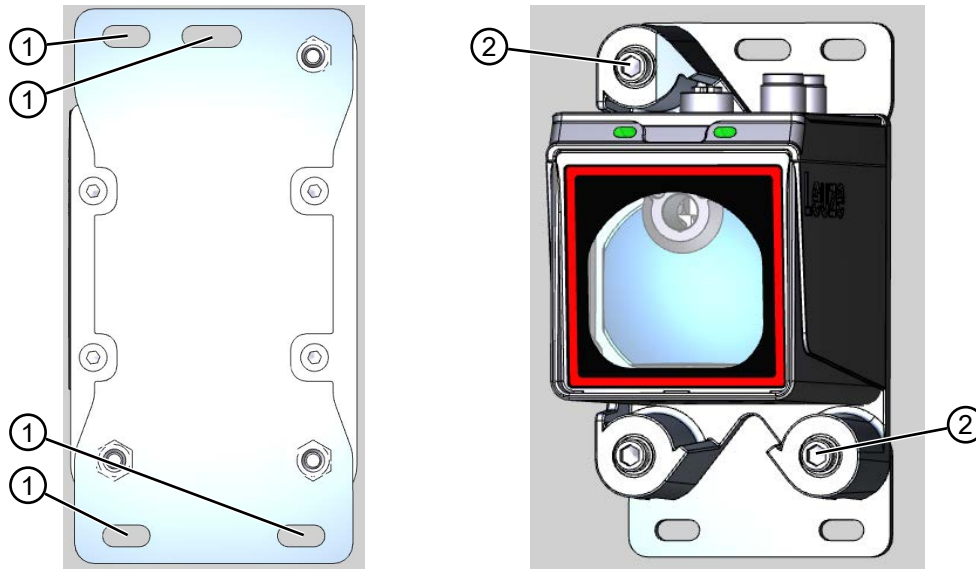

- 1 Slotted holes for mounting
- 2 Adjustment screws with hexagon socket WAF4

Fig. 5.2: Mounting with pre-mounted alignment unit

- ↪ Mount using four M5 screws.
- ↪ Guide the four M5 screws through the slotted holes of the alignment unit (1) and through the component to which the AMS 100i is to be attached.
- ↪ Secure the screws with a lock washer to protect against loosening caused by vibrations.

#### Aligning laser light spot

- ↪ Undo the adjustment screws WAF4 (2) a few turns.
- ↪ Align the laser light spot so that it always hits the center of the opposing reflector, both at close range as well as at the maximum measurement distance.
- ↪ Tighten the adjustment screws WAF4 (2).

To ensure that the light spot on the reflector does not move over the reflector across the entire measurement distance, the reflector and AMS should be installed vertically. If the light spot does not move during the process, i.e. when the distance changes, then installation is vertical.

### 5.2.2 Mounting with adapter plate (BT)

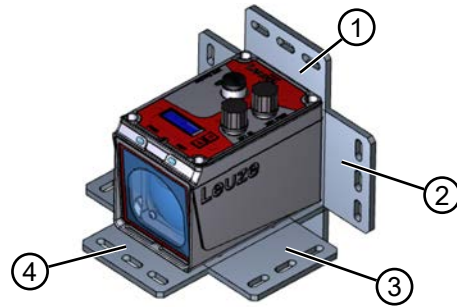

1 Mounting option 1  
3 Mounting option 3

2 Mounting option 2  
4 Mounting option 4

Fig. 5.3: Mounting options with adapter plate

- ↖ Position the adapter plate using one of the various options (1-4).
- ↖ Guide four screws (M4) from the rear side through the holes in the adapter plate.
- ↖ Screw the four screws (M4) into the internally threaded holes in the AMS 100i housing.

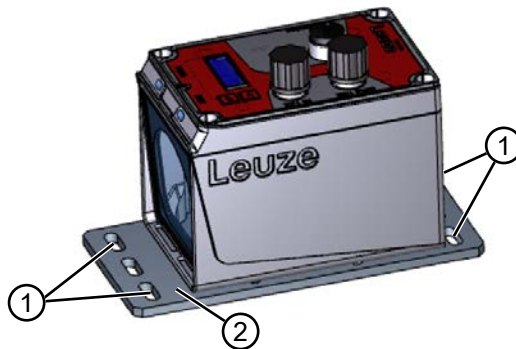

1 Slotted holes for mounting  
2 Adapter plate (BT)

Fig. 5.4: Mounting example with adapter plate (BT)

- ↖ Guide four screws (M5) through the slotted holes (1) of the adapter plate (2) and through the component to which the AMS 100i is to be attached.
- ↖ Secure the screws with lock washers and nuts.

#### Aligning laser light spot

To ensure that the light spot on the reflector does not move over the reflector across the entire measurement distance, the reflector and AMS should be installed vertically. If the light spot does not move during the process, i.e. when the distance changes, then installation is vertical.

### 5.2.3 Mounting without accessories

- ↖ Mount using the four screws (M4).
- ↖ Guide the four screws (M4) from the rear side through the component to which the AMS 100i is to be secured.
- ↖ Screw the screws (M4) into the internally threaded holes of the AMS 100i housing.

#### Aligning laser light spot

To ensure that the light spot on the reflector does not move over the reflector across the entire measurement distance, the reflector and AMS should be installed vertically. If the light spot does not move during the process, i.e. when the distance changes, then installation is vertical.

5.2.4 Parallel mounting

Definition of the term "parallel spacing"

The dimension X describes the "parallel spacing" of the inner edges of the two laser light spots on the reflector.

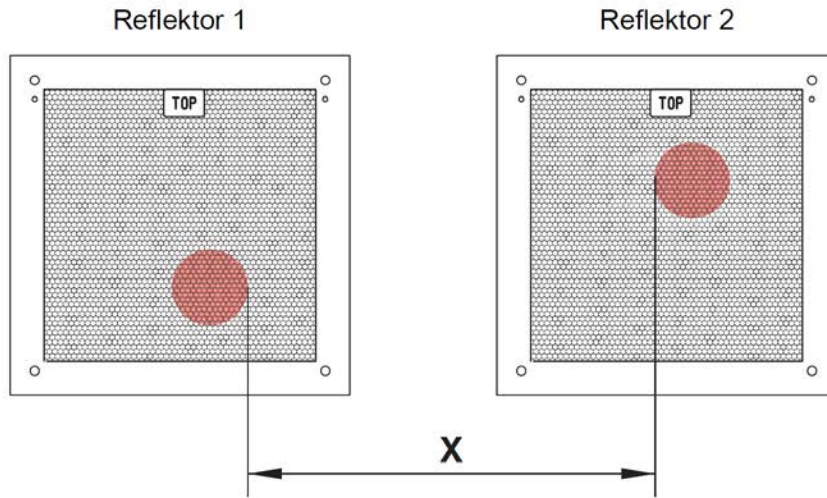

Fig. 5.5: Laser light spots parallel spacing

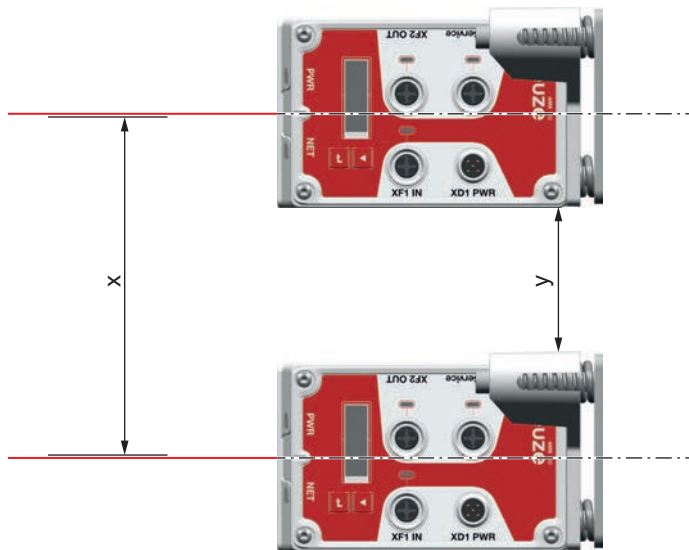

Fig. 5.6: Parallel mounting

The diameter of the laser spot increases with distance.

	AMS 100i
Max. measurement distance	200 m
Light spot diameter	≤ 160 mm

Thus, the center-to-center spacing of the two AMS 100i devices with respect to one another can be calculated as a function of the maximum measurement distance.

The minimum parallel spacing X between the two laser spots is always calculated using the following formula:

$$X = 100 \text{ mm} + (\text{max. measurement distance in mm} \times 0.01)$$

To define the minimum parallel spacing between two AMS 100i devices, it is necessary to distinguish between three different arrangements of AMS 100i and reflectors.

- The AMS 100i are mounted stationary and in parallel on one plane. Both reflectors move independently of one another at different distances to the AMS 100i.
- The AMS 100i are mounted stationary and in parallel on one plane. Both reflectors move in parallel at the same distance to the AMS 100i..

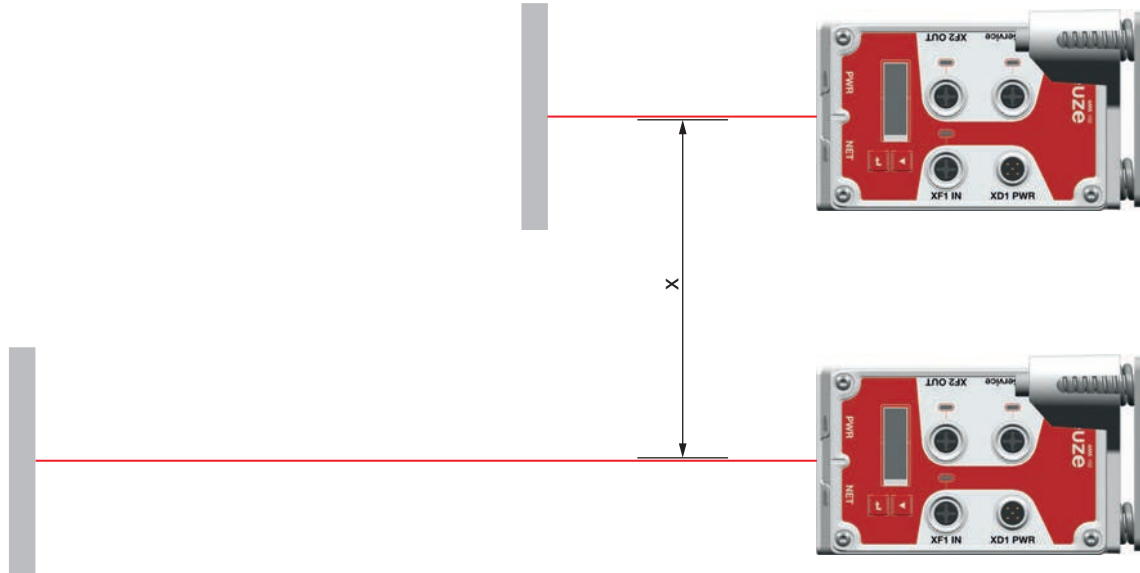

Fig. 5.7: Parallel mounting with moving reflectors

- The reflectors are mounted stationary and in parallel on one plane. Both AMS 100i move independently of one another at different or the same distances to the reflectors.

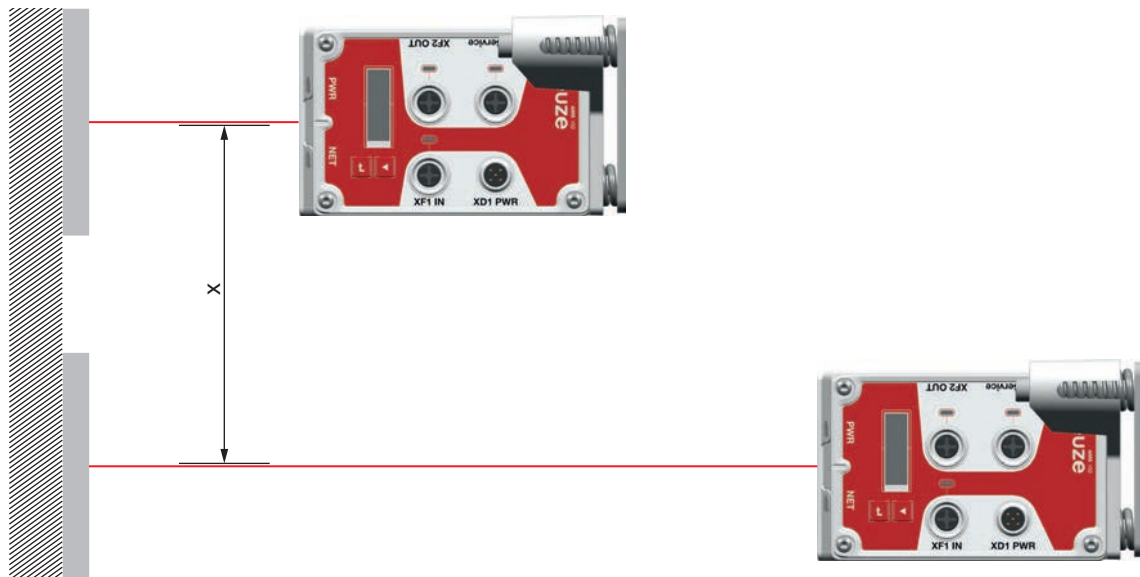

Fig. 5.8: Parallel mounting with moving AMS 100i units

**NOTICE**



Note that when the AMS 100i units are mounted in a mobile manner, travel tolerances could cause the two laser light spots to move towards each other.

- ↳ Take the travel tolerances of the vehicle into account when defining the parallel spacing of adjacent AMS 100i units.

**5.2.5 Parallel mounting of and DDLS optical data transmission**

The optical data transceivers of the DDLS series and the AMS 148i do not interfere with one another. Depending on the size of the reflector used, the DDLS can be mounted with a minimum parallel spacing of 100 mm to the AMS 148i. The parallel spacing is independent of the distance.

**5.2.6 Mounting with laser beam deflector units**

The two available deflector units are used for the 90° deflection of the laser beam, see chapter 13.3 "Accessories – Mounting".

<b>NOTICE</b>	
	<p>The deflector units are designed for a maximum operating range of 40 m. Longer distances can be achieved by independently optimizing the mechanical conditions.</p>

**Mounting of deflector unit with integrated mounting bracket**

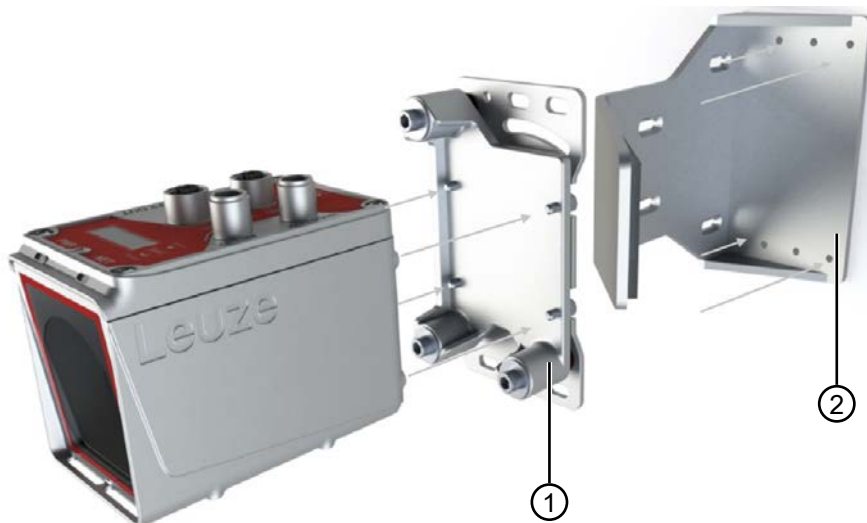

- 1 Pre-mounted alignment unit BTA
- 2 Deflector unit US AMS 02

Fig. 5.9: Mounting with laser beam deflector unit

- ✓ An AMS 1xxi BTA must be used with the US AMS 02 deflector unit.
- ↪ Use the four M5 screws to mount the deflector unit.
- ↪ Screw the AMS 100i together with the pre-mounted alignment unit (1) to the US AMS 02 deflector unit (2).
- ↪ Secure the screws with a lock washer to protect against loosening caused by vibrations.

The AMS 100i can be mounted in the deflector unit in two directions so that the cables lead off in the preferred direction.

In addition, the deflector unit can be mounted either underneath or on the rear side.

If deflection to the left or right is required, the entire deflector unit can be mounted accordingly.

The deflector unit is mounted on plane-parallel, flat walls or system parts. For error-free position measurement, there must be an unobstructed line-of-sight between the AMS 100i and the deflecting mirror as well as between the deflecting mirror and the reflector.

**Mounting of deflector unit without mounting bracket**

The US 1 OMS deflector unit and the AMS 100i are mounted separately.

- ↪ When mounting, make certain that the laser light spot of the AMS 100i is aligned with the center of the deflecting mirror.

To align the laser light spot with the reflector see chapter 5.2 "Mounting the device".

### 5.3 Mounting the reflector

The reflective tapes have a protective film that is easy to peel off.

- ↪ Remove the protective film before putting the overall system into operation.

#### Self-adhesive reflective tape

- ↪ Bond the self-adhesive reflective tapes of the "Reflective tape ...x...-S" series to a flat, clean and grease-free surface. It is recommended to use a separate carrier plate (not included in the scope of delivery).
- ↪ Using a sharp tool, cut the tape along the side of the prism structure.
- ↪ Tilt the reflective tape; see chapter 5.3.1 "Pitch of the reflector".

#### Reflective tape on carrier plate



The reflective tapes of the "Reflective tape ...x...-M" series have corresponding mounting holes.

Spacer sleeves are provided to enable mounting at the necessary pitch angle, see chapter 5.3.1 "Pitch of the reflector".

#### Reflective tape with heating

The reflective tapes of the "Reflective tape ...x...-H" series have corresponding mounting holes.

Due to the voltage supply affixed on the rear, the reflector cannot be mounted flat. Four spacer sleeves in two different lengths are supplied. Use the spacer sleeves to ensure separation from the wall as well as to provide the necessary pitch for avoiding surface reflection see chapter 5.3.1 "Pitch of the reflector".

	<b>WARNING</b>
	<p><b>Electrical work!</b> Electrical work must be carried out by a certified electrician.</p>

- ↪ Connect the cable to the nearest power distribution point.
- ↪ Observe the current consumptions listed in the technical data, see chapter 12.2.3 "Reflective tape with heating".

#### 5.3.1 Pitch of the reflector

- ↪ Connect the voltage supply of the AMS 100i.
- ↪ Mount the combination consisting of laser measurement system and reflective tape/reflector so that the laser light spot hits the film as centered as possible and without obstruction.
- ↪ To do so, use the mounting and adjustment options provided on the AMS 100i (see chapter 5.2 "Mounting the device").

<b>NOTICE</b>	
	<p>The reflector must be positioned at an angle. Use the spacer sleeves for this purpose. The correct pitch is given in the table "Reflector pitch".</p>

Tab. 5.1: Reflector pitch

Reflector type	Pitch using spacer sleeves	
Reflective tape 200x200-S Reflective tape 200x200-M	2 x 5 mm	
Reflective tape 200x200-H	2 x 15 mm	2 x 20 mm
Reflective tape 500x500-S Reflective tape 500x500-M	2 x 10 mm	
Reflective tape 500x500-H	2 x 15 mm	2 x 25 mm
Reflective tape 749x914-S	2 x 20 mm	
Reflective tape 914x914-S Reflective tape 914x914-M	2 x 20 mm	
Reflective tape 914x914-H	2 x 15 mm	2 x 35 mm

The spacer sleeves are included in the scope of delivery of reflective tapes ...-M and ...-H.

**NOTICE**

 Reliable operation, the max. operating range and accuracy of the AMS 100i can only be achieved with the reflective tape specified by Leuze. Correct operation cannot be guaranteed if other reflectors are used.

**Pitch of reflective tapes ...-S and ...-M**

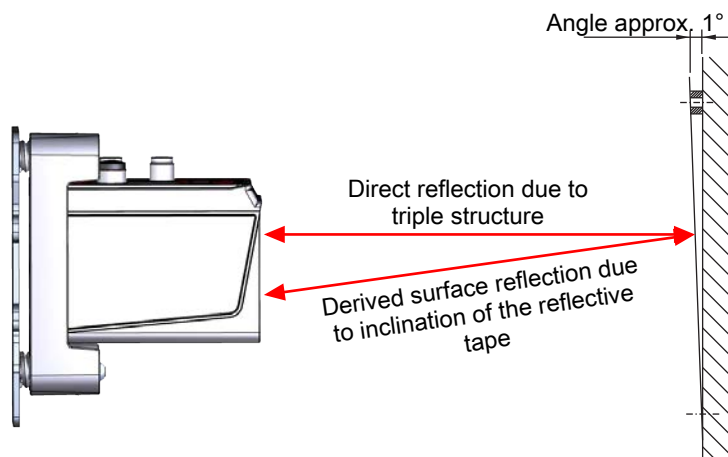

Fig. 5.10: Mounting the reflector

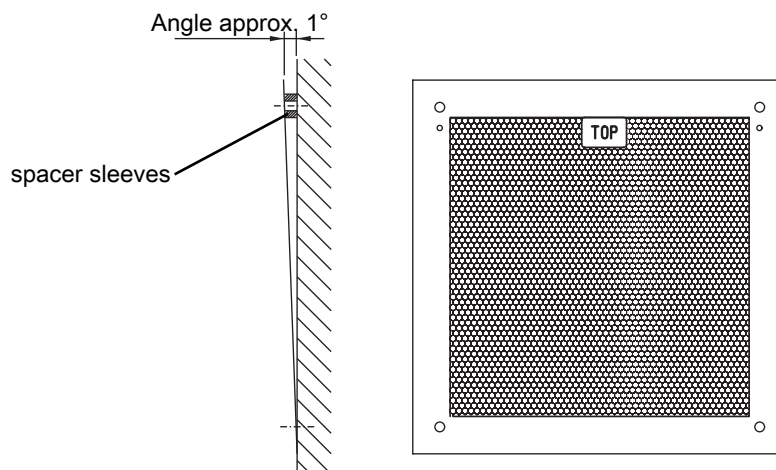

Fig. 5.11: Pitch of the reflector

Pitch of reflective tapes ...-H

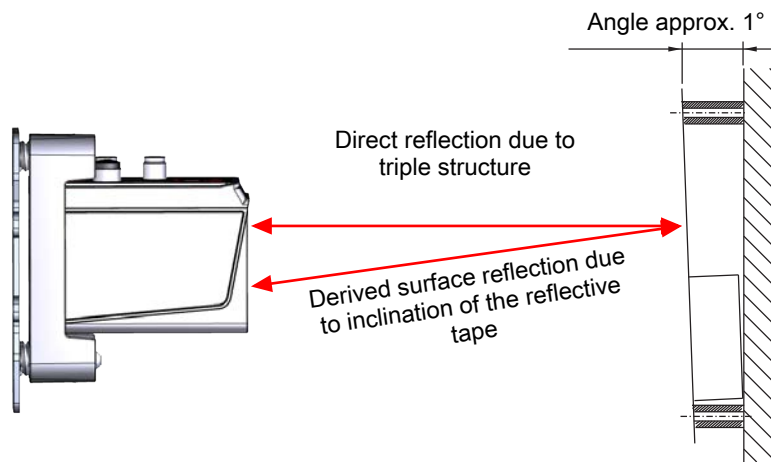

Fig. 5.12: Mounting of heated reflectors

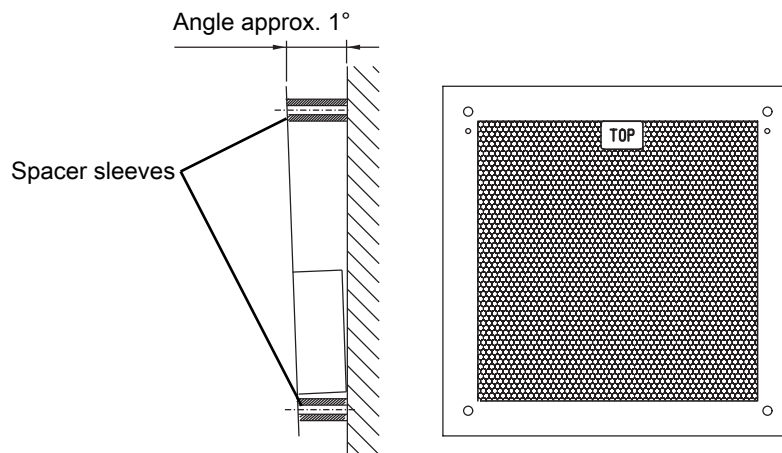

Fig. 5.13: Pitch of the heated reflector

## 6 Electrical connection

**CAUTION**



- ↪ Before connecting the device, be sure that the supply voltage agrees with the value printed on the name plate.
- ↪ Only allow competent persons to perform the electrical connection.
- ↪ Ensure that the functional earth (FE) is connected correctly. Fault-free operation is only guaranteed if the functional earth is connected properly.
- ↪ If faults cannot be rectified, take the device out of operation. Protect the device from accidentally being started.

**CAUTION**



**UL applications!**

For UL applications, the device must be powered by a PS2 in accordance with EN / IEC / UL 62368-1 or an LPS in accordance with EN / IEC / UL 60950-1 or NEC Class 2.

**NOTICE**



**Protective Extra Low Voltage (PELV)!**

The device is designed in accordance with protection class III for supply with PELV (Protective Extra-Low Voltage).

**NOTICE**



**Degree of protection IP65**

Degree of protection IP65 is achieved only if the connectors are screwed into place and caps installed.

The AMS 100i is connected using variously coded M12 connectors.

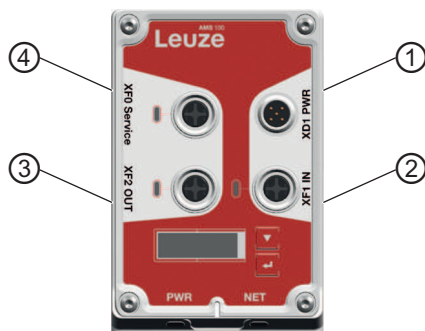

- 1 XD1 PWR – voltage supply / switching input/output
- 2 XF1 BUS IN
- 3 XF2 BUS OUT
- 4 XF0 Service

Fig. 6.1: AMS 148i connections

The corresponding mating connectors and preassembled cables are available as accessories for all connections, see chapter 13.5 "Accessories – connection technology".

### 6.1 PWR – voltage supply / switching input/output

M12 connector, 5-pin, A-coded

Tab. 6.1: PWR pin assignment

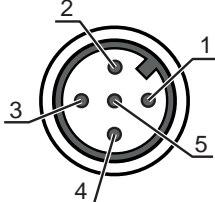
	Pin	Designation	Assignment
	1	VIN	Positive supply voltage +18 – +30 V DC
	2	I/O 1	Switching input/output 1
	3	GNDIN	Negative supply voltage 0 V DC
	4	I/O 2	Switching input/output 2
	5	FE	Functional earth
	Thread	FE	Functional earth (housing)

### 6.2 PROFINET

M12 connector, 4-pin, female, D-coded

Tab. 6.2: PROFINET BUS IN pin assignment

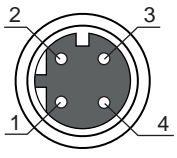
	Pin	Designation	Assignment
	1	TD +	Transmit Data +
	2	RD +	Receive Data +
	3	TD -	Transmit Data -
	4	RD -	Receive Data -
	Thread	FE	Functional earth (housing)

Tab. 6.3: PROFINET BUS OUT pin assignment

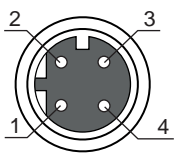
	Pin	Designation	Assignment
	1	TD +	Transmit Data +
	2	RD +	Receive Data +
	3	TD -	Transmit Data -
	4	RD -	Receive Data -
	Thread	FE	Functional earth (housing)

### 6.3 Service

M12 connection, 4-pin, female, D-coded

Tab. 6.4: Service pin assignment

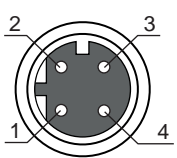
	Pin	Designation	Assignment
	1	TD +	Transmit Data +
	2	RD +	Receive Data +
	3	TD -	Transmit Data -
	4	RD -	Receive Data -
	Thread	FE	Functional earth (housing)

**NOTICE**



The service interface is designed only for use by Leuze.

## 7 Starting up – PROFINET interface

### 7.1 Basic configuration

As a rule, the AMS 148i is configured via the PROFINET interface.

<b>NOTICE</b>	
	<p><b>Observe when configuring PROFINET devices!</b></p> <ul style="list-style-type: none"> <li>↳ Always perform the basic configuration using the Generic Station Description Markup Language (GSDML) file.</li> <li>↳ Download the appropriate file from the Internet.</li> <li>↳ In process operation, only the parameters in the PROFINET modules set via the GSDML file or the PROFINET default presets are in effect. If you switch the device to the <i>Service</i> operating mode using the webConfig tool, the device will be disconnected from PROFINET. All parameters set via the GSDML file initially remain in effect.</li> </ul>

The AMS 148i is designed as a PROFINET-RT device (Real Time; acc. to IEEE 802.3). It supports a transmission rate of up to 100 Mbit/s (100 Base TX/FX), full duplex, as well as auto-negotiation and auto-cross-over.

- The device's functionality is defined by parameter sets organized into modules. The modules are part of the Generic Station Description Markup Language (GSDML) file.
- Each AMS 148i has a unique MAC address (Media Access Control) that is specified on the name plate. The MAC address (MAC-ID) is linked to an IP address during the course of configuration.
- The SIMATIC Manager for creation of PROFINET networks links the IP address to a freely selectable device name which may only exist once in the network.

<b>NOTICE</b>	
	<p>Each device with Ethernet interface is uniquely identified via the MAC address assigned during production. The MAC address is also listed on the name plate of the device.</p> <p>If multiple devices are commissioned in a system, the MAC address of each installed device must be correctly assigned, e.g., during programming of the control.</p>

#### 7.1.1 PROFINET - communication profile

The PROFINET communication profile defines how participants serially transmit their data via the transmission medium. Data exchange with the devices occurs primarily cyclically. For configuration, operation, observation and alarm handling, acyclic communication services are, however, used as well.

Depending on the communication requirements, PROFINET offers suitable protocols and transfer methods:

- Real Time communication (RT) via prioritized Ethernet frames:
  - Cyclical process data (I/O data stored in the I/O area of the control)
  - Alarms
  - Neighborhood information
  - Address assignment/address resolution via DCP
- TCP/UDP/IP communication via standard Ethernet TCP/UDP/IP frames:
  - Establishing communication
  - Acyclical data exchange, i.e. Transmission of various types of information:
    - Parameters for the module configuration while communication is being established
    - I&M data (Identification & Maintenance functions)
    - Reading diagnostic information
    - Reading I/O data
    - Writing device data

### 7.1.2 Conformance Classes

PROFINET devices are categorized into conformance classes to simplify the evaluation and selection of the devices for the users.

The AMS 148i corresponds to Conformance Class B (CC-B) and can use an existing Ethernet network infrastructure.

The AMS supports the following features:

- Cyclical RT communication
- Acyclic TCP/IP communication
- Alarms/diagnosis
- Automatic address assignment
- Identification & Maintenance functions IM0 – IM4
- Neighborhood detection 100 Base-TX/FX
- Convenient device exchange without engineering tools
- SNMP support

### 7.1.3 Identification and Maintenance functions

The AMS 148i supports the base record I&M0.

Tab. 7.1: Base record I&M0

Contents	Index	Data type	Description	Value
Header	0	10 bytes	Manufacturer specific	-
MANUFACTURER_ID	10	UNSIGNED16	Leuze manufacturer ID	338
ORDER_ID	12	ASCII string 20 bytes	Leuze - part number	-
SERIAL_NUMBER	32	ASCII string 16 bytes	Unique device serial number	Device-dependent
HARDWARE_REVISION	48	UNSIGNED16	Hardware revision number, e.g., "0 – 65535"	Device-dependent
SOFTWARE_REVISION	50	1x CHAR, 3x UNSIGNED8	Software version number, e.g., V130 corresponds to "V1.3.0"	Device-dependent
REVISION_COUNTER	54	UNSIGNED16	Is incremented when updating individual modules. This function is not supported.	0
PROFILE_ID	56	UNSIGNED16	PROFINET application profile number	0xF600 (Generic Device)
PROFILE_SPECIFIC_TYPE	58	UNSIGNED16	Info about subchannels and submodules. Not relevant	0x01.0x01
IM_VERSION	60	2x UNSIGNED8	Implemented I&M version V 1.1	0x01.0x01
IM_SUPPORTED	62	Bit [16]	Optional I&M records available	4

## 7.2 Topologies

### 7.2.1 Star topology

The AMS 148i can be operated as a single device (stand-alone) with an individual device name in a star topology. The PLC must communicate this device name to the participant during the "device naming".



- A PC / PLC host interface
- B Other network participants

Fig. 7.1: PROFINET in a star topology

### 7.2.2 Linear topology

The AMS 148i with integrated switch functionality offers the option of connecting multiple laser measurement systems of type AMS 148i to one another without direct connection to a switch. In addition to the classic "star topology", a "linear topology" is thus also possible.

The maximum length of a segment (from the host to the furthest participant) is limited to 100 m.

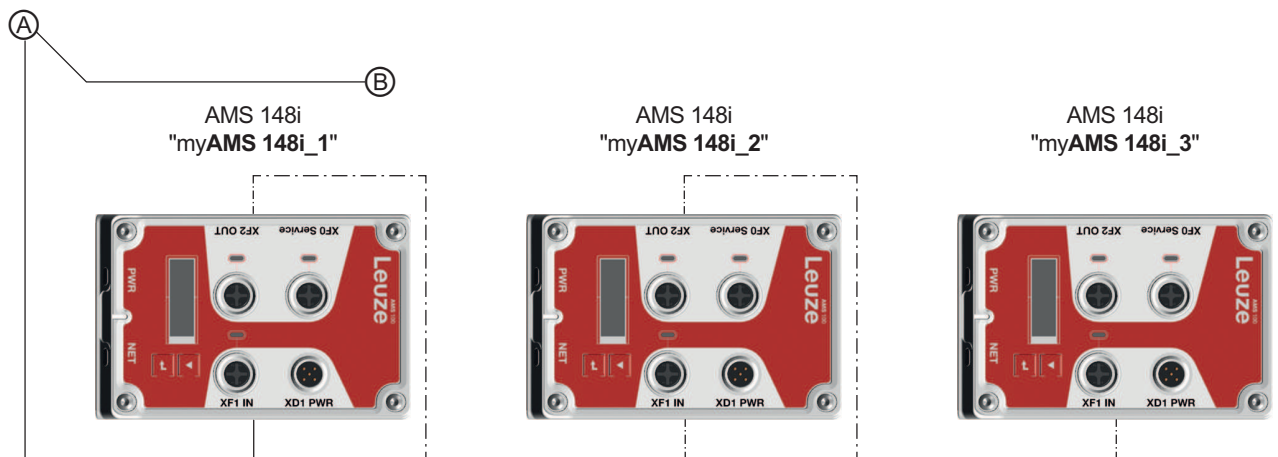

- A PC / PLC host interface
- B To other network participants

Fig. 7.2: PROFINET in a linear topology

## 7.3 Cable lengths and shielding

👉 Observe the maximum cable lengths and shielding.

Tab. 7.2: Cable lengths and shielding

Connection	Interface	Max. cable length	Shielding
AMS host	PROFINET-RT	100 m	Absolutely required
Network from the first AMS to the last AMS	PROFINET-RT	The maximum segment length must not exceed 100 m for 100 Base-TX twisted pair (min. Cat. 5).	Absolutely required

## 7.4 Starting the device

To start the AMS:

- ↪ Connect the supply voltage. The AMS boots up and displays the device status and position value.
- ↪ Configure the AMS, e.g., for a Siemens SIMATIC-S7 control.
- ↪ Assign the AMS its individual device name and name the device.

### NOTICE



The default value of the input data bits after switching on the device corresponds to the specified initial value (generally ZERO).

### NOTICE



For output data with status IOPS = Bad, the downstream functions are switched to a safe state. For example, an activated device or an output is deactivated. This is the case, for example, if the control is switched to the STOP mode.

In the event of a connection interruption, the device behaves in the same way.

The outputs are deactivated during device start-up.

## 7.5 Configuring for the Siemens SIMATIC-S7 control

The functionality of the AMS is defined via parameter sets which are organized in modules. The modules are part of the GSDML file (Generic Station Description Markup Language), which is included in the scope of delivery as an integral part of the device.

By using an application-specific configuration tool, such as, e.g. Siemens TIA-Portal for the Siemens PLC, the required modules are integrated into a project during commissioning and its settings and parameters are configured accordingly. These modules are provided by the GSDML file.

The following steps are necessary for commissioning:

- Preparation of the control system (S7 PLC)
- Installation of the GSDML file
- Hardware configuration of the S7 PLC
- Transmission of the PROFINET configuration to the IO Controller (S7 PLC)
- Device naming
- Check device name

Proceed as follows:

- ↪ To prepare the control (S7 PLC):
  - Assign an IP address to the IO controller (S7 PLC).
  - Prepare the control system for consistent data transmission.
- ↪ Install the GSDML file for the subsequent configuration of the AMS.
  - You can find the GSDML file at [www.leuze.com](http://www.leuze.com) > Products > Measuring sensors > Sensors for positioning > Laser positioning systems > AMS 100i > (Name of AMS) > Register downloads > Software/driver > GSDML file.

### General information on the GSDML file

The term GSD (Generic Station Description) stands for the textual description of a PROFINET device model. For the description of the complex PROFINET device model, the XML-based GSDML (Generic Station Description Markup Language) was introduced. In the following, the terms "GSD" or "GSD file" always refer to the GSDML-based format.

The GSDML file can support an arbitrary number of languages in one file.

Every GSDML file contains a version of the AMS device model. This is also reflected in the file name.

#### NOTICE



The GSDML file is a certified and integral part of the device and must not be changed manually. The GSDML file is not changed by the system either.

- In the GSDML file, all data necessary for operating the AMS is described in modules:
  - Input and output data
  - Device parameter
  - Definition of control bits or status bits
- If parameters are changed in the project tool, for example, these changes are stored by the control in the project, not in the GSDML file.

The functionality of the AMS is defined via parameter sets. The parameters and their functions are structured in the GSDML file using modules. A user-specific configuration tool is used during PLC program creation to integrate the required modules and configure them appropriately for their respective use.

During operation of the AMS on the PROFINET all parameters are set to default values. If these parameters are not changed by the user, the device functions with the default settings delivered by Leuze. The default settings of the AMS can be found in the module descriptions.

### GSDML file name structure

The file name of the GSDML file is constructed according to the following rule:

#### GSDML-[GSDML schema version]-Leuze-[item description]-[date].xml

- **[GSDML schema version]** = Version identifier of the GSDML schema version used, e.g., V2.2
- **[Date]** = Release date of the GSDML file in the format `yyyymmdd`  
This date also stands for the release date of the file.

Further procedure:

- ↳ Configure the hardware of the S7 PLC:  
Add the AMS to your project. The PROFINET system is configured with the help of the hardware configuration (*HW-Config*) of the SIMATIC Manager.  
Assign an IP address a unique device name.
- ↳ Transfer the PROFINET configuration to the IO Controller (S7 PLC).

Following successful transfer, the following activities take place automatically:

- Check of device names
- Assigning the IP addresses configured in the *HW-Config* to the I/O devices
- Establishment of a connection between the IO Controller and configured IO devices
- Cyclical data exchange

#### NOTICE



Participants that have not been "named" cannot be contacted yet at this point in time.

**Device naming**

PROFINET defines the "naming of the device" as the creation of a name-based relationship for a PROFINET device.

- ↪ Set the device name.  
The PROFINET device has a unique MAC address that is part of the factory settings. The MAC address may be found on the name plate of the AMS. Multiple AMS devices can be distinguished by the MAC addresses displayed.  
This information is used to assign a unique, plant-specific device name ("NameOfStation") to the device via the "Discovery and Configuration Protocol (DCP)". Every time the system is started up, PROFINET uses the DCP protocol for the IP address assignment, provided the IO-device is located in the same subnet.
- ↪ Assign the device names to the configured IO devices.  
Select the AMS using its MAC address. The AMS is then assigned the unique device name (which must match the one in the *HW Config* ).
- ↪ Assign the IP address to the MAC address (individual device name).  
At this point, assign another IP address (suggested by the control), a subnet mask and, if required, a router address, and assign this data to the named participant (device name).  
From now on, and when programming, only the unique device name (max. 255 characters) is used.
- ↪ Check device name  
After completing the configuration phase, check the device names that have been assigned.

<b>NOTICE</b>	
	<p><b>Assign unique device names!</b></p> <ul style="list-style-type: none"> <li>↪ Ensure that the device names are unique and that all participants are located in the same subnet.</li> </ul>

**7.6 PROFINET project modules**

From the perspective of the device, a distinction is made between interface-specific parameters and internal parameters:

- Interface-specific parameters  
Parameters that can be changed via the interface (see modules described in the following).
- Internal parameters  
Parameters that are changed only via a service interface. They retain their value even after the interface-specific configuration.

<b>NOTICE</b>	
	<p><b>Overwriting of data by PLC!</b></p> <ul style="list-style-type: none"> <li>↪ Note that the PLC overwrites the data set via the service interface.</li> <li>↪ During the interface-specific configuration phase, all interface-specific parameters changed via the service interface are overwritten. This also applies for the parameters from modules that were not configured.</li> <li>↪ During the configuration phase, the device receives parameter telegrams from the IO controller (master). Before the parameter telegrams are evaluated and the respective parameter values are set, all interface-specific parameters are reset to default values. This ensures that the parameters of modules that are not selected are set to the default values.</li> </ul>

<b>NOTICE</b>	
	<p>You can find the default values of the device in the module descriptions.</p>

## 7.7 Overview of the modules

Tab. 7.3: PROFINET modules

Module ID	Module name	Module content
1001	M1 position value	Sign, unit, resolution, counting direction, offset, filter type, position value
1002	Static M2 preset	Preset value, Preset teach, Preset reset
1003	M3 I/O 1 Input/Output	Functions, activation, limit value 1 position, limit value 2 position, velocity limit value, intensity (ATT), temperature (TMP), laser (LSR), plausibility (PLB), hardware (ERR), pseudodynamic output, control input, input status, output status settings
1004	M4 I/O 2 Input/Output	Functions, activation, limit value 1 position, limit value 2 position, velocity limit value, intensity (ATT), temperature (TMP), laser (LSR), plausibility (PLB), hardware (ERR), pseudodynamic output, control input, input status, output status settings
1005	M5 status and control	Hardware (ERR), lower position limit value 1, upper position limit value 1, lower position limit value 2, upper position limit value 2, laser status, preset status, preset teach, reserve, intensity (ATT), temperature (TMP), laser (LSR), validity (PLB), laser (LSR)
1006	M6 position limit value 1	Lower position value limit 1, upper position value limit 1
1007	M7 position limit value 2	Lower position value limit 2, upper position value limit 2
1008	M8 error handling procedures	Position value in case of error, Reserve B0, suppress position status, error delay (position), error delay time (position), velocity in case of error, reserve B3, suppress velocity status, error delay (velocity), error delay time (velocity)
1009	M9 velocity	Velocity resolution, averaging, velocity
1010	M10 velocity limit value 1	Switching type, direction selection, velocity limit value 1, velocity hysteresis 1, limit value 1 range start, limit value 1 range end
1011	M11 velocity limit value 2	Switching mode, direction selection, velocity limit value 2, velocity hysteresis 2, limit value 2 range start, limit value 2 range end
1012	M12 velocity status	Velocity limit value 1 comparison, Velocity limit value 2 comparison, Velocity measurement error, movement status, direction of movement, Velocity limit value status 1, Velocity limit value status 2
1013	M13 miscellaneous	Language selection, display illumination, enable/disable password, password, heating control
1014	M14 condition monitoring	Operating time, temperature

## 7.8 Module M1 – Position value

Module ID: 1001

Submodule ID: 1

### Description

Outputs the current position value

The parameters for sign, unit, resolution, counting direction and offset remain adjustable.

<b>NOTICE</b>	
	<p><b>Convert numerical values when changing the unit of measurement!</b></p> <p>↳ If the unit of measurement is changed from metric to inch (or vice versa), previously entered numerical values (e.g. for offset, preset, limit values etc.) are not automatically converted. Example: Offset = 10000 mm after changing from metric to inch: Offset = 10000 in/100</p> <p>↳ Manually convert the numerical values when changing the unit of measurement.</p>

Tab. 7.4: Parameter

Parameter	Rel. addr.	Data type	Data length	Min. value	Max. value	Default	Unit
Sign	0.0	Bit	1	0	1	0	
Unit	0.1	Bit	1	0	1	0	
Resolution	0.2	Bit	3	1	5	4	
Counting direction	0.5	Bit	1	0	1	0	
Offset	1.0	Integer32	1	-999999	999999	0	
Filter type	5.0	Bit	3	0	4	0	

Tab. 7.5: Input data

Input	Rel. addr.	Data type	Data length	Min. value	Max. value	Default	Unit
Position value	0.0	Integer32	1	-999999	999999	0	

### Sign

Output mode of the sign

Sign affects position and velocity output

**0 = Two's complement**

1 = Sign + magnitude

### Unit

Selection of the unit

The parameter applies to all values with units. The parameter applies to all interfaces.

**0 = Metric – mm**

1 = Inch – in/100

**Resolution**

Resolution of the position value

Affects only the PROFINET output.

001 = 1: 0.001

010 = 2: 0.01

011 = 3: 0.1

**100 = 4: 1**

101 = 5: 10

The resolution has no effect on:

- Position limit values
- Static preset
- Offset

**Counting direction**

This parameter defines the counting direction for the position and velocity limits.

**0 = Positive**

1 = Negative

Counting direction **Positive**: The counter increases from 0 as the distance from the sensor increases.

Counting direction **Negative**: The value goes negative starting from 0 as the distance from the sensor increases.

The parameter applies to all interfaces.

The counting direction changes the sign during velocity measurement.

**Offset**

This parameter contains the offset value in mm or in/100 for calculating the position value.

**Output value = measurement value + offset**

The parameter applies to all interfaces.

**NOTICE! If the preset is activated, this has priority over the offset. Preset and offset are not offset against each other.**

The resolution of the offset value is independent of the resolution selected in module 1.

The entered offset applies immediately without any further release.

**Filter type**

Sets a filter type for post-processing measured values.

The type of filter used can optimize repeatability in the application.

**000 = 0: Normal**

001 = 1: High

010 = 2: Slow

011 = 3: Compatibility mode

NOTE: With filters 0, 1, and 2, there is no dynamic measurement error (contouring error). The dynamic measurement error must only be taken into account when the filter setting is 011: Compatibility Mode with AMS 300.

**Position value**

Output of the current position value in mm or in/100, scaled according to the resolution parameters.

## 7.9 Module M2: Static preset

Module ID: 1002

Submodule ID: 1

### Description

With this module, a preset value can be specified. The specified preset value becomes active in the position in which preset teaching is performed.

The activated preset overrides/disables the offset value that is added to the position value calculation.

<b>NOTICE</b>	
	In the event of a device change, the preset value is retained in the PROFINET manager. The preset value (preset teach) must, however, be activated again at the intended position.

Tab. 7.6: Parameter

Parameter	Rel. addr.	Data type	Data length	Min. value	Max. value	Default	Unit
Preset value	0.0	Integer32	1	-999999	999999	0	

Tab. 7.7: Output data

Output	Rel. addr.	Data type	Data length	Min. value	Max. value	Default	Unit
Preset teach	0.0	Bit	1	0	1	0	
Preset reset	0.1	Bit	1	0	1	0	

### Preset value

Preset value in mm or in/100

The value is accepted during a corresponding teach event (see Output data).

The resolution of the preset value is independent of the resolution selected in module 1.

### Preset teach

Read in the preset value

**0 > 1** = Preset teach

### Preset reset

The preset value is disabled.

This reactivates the offset value in the output of the position value calculation.

**0 > 1** = Preset reset

## 7.10 Module M3: I/O 1 Input / Output

Module ID: 1003

Submodule ID: 1

### Description

The module defines the mode of operation of the digital input/output I/O 1.

The parameters set in bytes 1 and 2 define which event triggers the output data. The individual functions are OR-linked.

<b>NOTICE</b>	
	<p>AMS 148i behavior when the laser is ON/OFF: If the laser light spot is positioned on the reflector when the laser diode is switched on, the AMS 148i returns valid measurement values after approx. 330 ms.</p>

Tab. 7.8: Parameter

Parameter	Rel. addr.	Data type	Data length	Min. value	Max. value	Default	Unit
Function	0.0	Bit	1	0	1	1	
Activation	0.1	Bit	1	0	1	0	
Position limit value 1	1.0	Bit	1	0	1	0	
Position limit value 2	1.1	Bit	1	0	1	0	
Velocity limit value	1.2	Bit	1	0	1	0	
Intensity (ATT)	1.3	Bit	1	0	1	0	
Temperature (TMP)	1.4	Bit	1	0	1	0	
Laser (LSR)	1.5	Bit	1	0	1	0	
Plausibility (PLB)	1.6	Bit	1	0	1	1	
Hardware (ERR)	1.7	Bit	1	0	1	1	
Pseudodynamic output	2.0	Bit	1	0	1	0	
Input control	3.0	Bit	3	0	2	0	

Tab. 7.9: Input data

Input	Rel. addr.	Data type	Data length	Min. value	Max. value	Default	Unit
State	0.0	Bit	1	0	1	0	

Tab. 7.10: Output data

Output	Rel. addr.	Data type	Data length	Min. value	Max. value	Default	Unit
State	0.0	Bit	1	0	1	0	

### Function

The parameter defines whether I/O 1 functions as an input or as an output.

0 = Input

**1 = Output**

**Activation**

The parameter defines the level of the output at which the "Output" event occurs. If I/O 1 is configured as an input, the response is edge-triggered.

**0 = Low active / 1 > 0 transition**

1 = High active / 0 > 1 transition

**Position limit value 1**

If the position value is outside of configured limit range 1, the output is set.

**0 = OFF (deactivated)**

1 = ON (activated)

**Position limit value 2**

If the position value is outside of configured limit range 2, the output is set.

**0 = OFF (deactivated)**

1 = ON (activated)

**Velocity limit value**

If the velocity value is outside of the configured values, the output is set.

Monitoring from modules 10 to 11 is OR-linked.

**0 = OFF (deactivated)**

1 = ON (activated)

**Intensity (ATT)**

If the intensity of the received signal is less than the warning threshold, the output is set.

**0 = OFF (deactivated)**

1 = ON (activated)

**Temperature (TMP)**

If the internal device temperature exceeds the set limit value, the output is set.

**0 = OFF (deactivated)**

1 = ON (activated)

**Laser (LSR)**

Laser prefailure message

**0 = OFF (deactivated)**

1 = ON (activated)

**Plausibility (PLB)**

If implausible measurement values are diagnosed, the output is set.

0 = OFF (deactivated)

**1 = ON (activated)**

**Hardware (ERR)**

If a hardware error is diagnosed, the output is set.

0 = OFF (deactivated)

**1 = ON (activated)**

**Pseudodynamic output**

If bit 0.0 is set in the output data, the output is set.

**0 = OFF (deactivated)**

1 = ON (activated)

**Input control**

This parameter defines which event is triggered by the edge detected at the hardware input.

**000 = Hardware input no function**

001 = Hardware input as preset teach function

010 = Hardware input as laser OFF function

**Preset**

The HW input is used as a preset teach input.

**Laser**

The hardware input is used as laser ON/OFF.

**Input data**

Input or output signal status

**0 = Input/output not active at signal level**

1 = Input/output active at signal level

**Output data**

The output can be activated/deactivated with this bit. The corresponding release is set in module M3, output parameter "Pseudodynamic output" (bit 2.0).

**0 = Output not active at signal level**

1 = Output active at signal level

## 7.11 Module M4: I/O 2 Input / Output

Module ID: 1004

Submodule ID: 1

### Description

The module defines the mode of operation of the digital input/output I/O 2.

The parameters set in bytes 1 and 2 define which event triggers the output data. The individual functions are OR-linked.

<b>NOTICE</b>	
	<p>AMS 148i behavior when the laser is ON/OFF: If the laser light spot is positioned on the reflector when the laser diode is switched on, the AMS 148i returns valid measurement values after approx. 330 ms.</p>

Tab. 7.11: Parameter

Parameter	Rel. addr.	Data type	Data length	Min. value	Max. value	Default	Unit
Function	0.0	Bit	1	0	1	1	
Activation	0.1	Bit	1	0	1	0	
Position limit value 1	1.0	Bit	1	0	1	0	
Position limit value 2	1.1	Bit	1	0	1	0	
Velocity limit value	1.2	Bit	1	0	1	0	
Intensity (ATT)	1.3	Bit	1	0	1	1	
Temperature (TMP)	1.4	Bit	1	0	1	1	
Laser (LSR)	1.5	Bit	1	0	1	1	
Plausibility (PLB)	1.6	Bit	1	0	1	0	
Hardware (ERR)	1.7	Bit	1	0	1	0	
Pseudodynamic output	2.0	Bit	1	0	1	0	
Input control	3.0	Bit	3	0	2	0	

Tab. 7.12: Input data

Input	Rel. addr.	Data type	Data length	Min. value	Max. value	Default	Unit
State	0.0	Bit	1	0	1	0	

Tab. 7.13: Output data

Output	Rel. addr.	Data type	Data length	Min. value	Max. value	Default	Unit
State	0.0	Bit	1	0	1	0	

### Function

The parameter defines whether I/O 2 functions as an input or as an output.

0 = Input

**1 = Output**

**Activation**

The parameter defines the level of the output at which the "Output" event occurs. If I/O 2 is configured as an input, the response is edge-triggered.

**0 = Low active / 1 > 0 transition**

1 = High active / 0 > 1 transition

**Position limit value 1**

If the position value is outside of configured limit range 1, the output is set.

**0 = OFF (deactivated)**

1 = ON (activated)

**Position limit value 2**

If the position value is outside of configured limit range 2, the output is set.

**0 = OFF (deactivated)**

1 = ON (activated)

**Velocity limit value**

If the velocity value is outside of the configured values, the output is set.

Monitoring from modules 10 to 11 is OR-linked.

**0 = OFF (deactivated)**

1 = ON (activated)

**Intensity (ATT)**

If the intensity of the received signal is less than the warning threshold, the output is set.

0 = OFF (deactivated)

**1 = ON (activated)**

**Temperature (TMP)**

If the internal device temperature exceeds the set limit value, the output is set.

0 = OFF (deactivated)

**1 = ON (activated)**

**Laser (LSR)**

Laser prefailure message

0 = OFF (deactivated)

**1 = ON (activated)**

**Plausibility (PLB)**

If implausible measurement values are diagnosed, the output is set.

**0 = OFF (deactivated)**

1 = ON (activated)

**Hardware (ERR)**

If a hardware error is diagnosed, the output is set.

**0 = OFF (deactivated)**

1 = ON (activated)

**Pseudodynamic output**

If bit 0.0 is set in the output data, the output is set.

**0 = OFF (deactivated)**

1 = ON (activated)

**Input control**

This parameter defines which event is triggered by the edge detected at the hardware input.

**000 = Hardware input no function**

001 = Hardware input as preset teach function

010 = Hardware input as laser OFF function

**Preset**

The HW input is used as a preset teach input.

**Laser**

The hardware input is used as laser ON/OFF.

**Input data**

Input or output signal status

**0 = Input/output not active at signal level**

1 = Input/output active at signal level

**Output data**

The output can be activated/deactivated with this bit. The corresponding release is set in module M3, output parameter "Pseudodynamic output" (bit 2.0).

**0 = Output not active at signal level**

1 = Output active at signal level

## 7.12 Module M5: Status and control

**Module ID: 1005**

**Submodule ID: 1**

### Description

The module signals various status information of the AMS 148i. The laser can be controlled via the master's output data.

### Parameter

None

Tab. 7.14: Input data

Input	Rel. addr.	Data type	Data length	Min. value	Max. value	Default	Unit
Hardware (ERR)	0.0	Bit	1	0	1	0	
Lower position limit value 1	0.4	Bit	1	0	1	0	
Upper position limit value 1	0.5	Bit	1	0	1	0	
Lower position limit value 2	0.6	Bit	1	0	1	0	
Upper position limit value 2	0.7	Bit	1	0	1	0	
Laser status	1.0	Bit	1	0	1	0	
Preset status	1.1	Bit	1	0	1	0	
Preset teach	1.2	Bit	1	0	1	0	
Reserve	1.3	Bit	1	0	1	0	
Intensity (ATT)	1.4	Bit	1	0	1	0	
Temperature (TMP)	1.5	Bit	1	0	1	0	
Laser (LSR)	1.6	Bit	1	0	1	0	
Plausibility (PLB)	1.7	Bit	1	0	1	0	

Tab. 7.15: Output data

Output	Rel. addr.	Data type	Data length	Min. value	Max. value	Default	Unit
Laser	0.0	Bit	1	0	1	0	

### Hardware (ERR)

If a hardware error is diagnosed, the status bit is set.

**0 = OK**

1 = Hardware error

### Lower position limit value 1

Signals that the value is less than lower limit value 1.

**0 = OK**

1 = Value less than limit

**Upper position limit value 1**

Signals that the value is greater than upper limit value 1.

**0 = OK**

1 = Value greater than limit

**Lower position limit value 2**

Signals that the value is less than lower limit value 2.

**0 = OK**

1 = Value less than limit

**Upper position limit value 2**

Signals that the value is greater than upper limit value 2.

**0 = OK**

1 = Value greater than limit

**Laser status**

Signals the laser status.

**0 = Laser ON**

1 = Laser OFF

**Preset status**

State of the preset value

**0 = Preset inactive**

1 = Preset active

**Preset teach**

This bit toggles at each teach event of a preset value.

**0 > 1, 1 > 0 = Preset Teach enabled**

**Reserve****Intensity (ATT)**

If the intensity of the received signal is less than the warning threshold, the status bit is set.

**0 = OK**

1 = Warning

**Temperature (TMP)**

If the internal device temperature exceeds or drops below the set limit value, the status bit is set.

**0 = OK**

1 = Temperature above/below limit

**Laser (LSR)**

Laser prefailure message

**0 = OK**

1 = Laser warning

**Plausibility (PLB)**

If implausible measurement values are diagnosed, the status bit is set.

**0 = OK**

1 = Implausible measurement values

**Laser**

Actuation of the laser

**0 = Laser ON**

1 = Laser OFF

**7.13 Module M6 – Position limit value range 1****Module ID: 1006****Submodule ID: 1****Description**

The Position limit value range 1 parameter defines a distance range with lower and upper limit. If the measured value is outside the configured range, the corresponding bit is set in module M5 or, if configured, an output is set.

Tab. 7.16: Parameter

Parameter	Rel. addr.	Data type	Data length	Min. value	Max. value	Default	Unit
Lower position limit 1	0.0	Integer32	1	-999999	999999	0	
Upper position limit 1	4.0	Integer32	1	-999999	999999	0	

**Input data**

None

**Output data**

None

**Lower position limit 1**

Specifies the lower position limit in mm or in/100.

The resolution of the preset value is independent of the resolution selected in module M1.

**Upper position limit 1**

Specifies the upper position limit in mm or in/100.

The resolution of the preset value is independent of the resolution selected in module M1.

**7.14 Module M7 – Position limit value range 2****Module ID: 1007****Submodule ID: 1****Description**

The Position limit value range 2 parameter defines a distance range with lower and upper limit. If the measured value is outside the configured range, the corresponding bit is set in module M5 or, if configured, an output is set.

Tab. 7.17: Parameter

Parameter	Rel. addr.	Data type	Data length	Min. value	Max. value	Default	Unit
Lower position limit 2	0.0	Integer32	1	-999999	999999	0	
Upper position limit 2	4.0	Integer32	1	-999999	999999	0	

**Input data**

None

**Output data**

None

**Lower position limit 2**

Specifies the lower position limit in mm or in/100.

The resolution of the preset value is independent of the resolution selected in module M1.

**Upper position limit 2**

Specifies the upper position limit in mm or in/100.

The resolution of the preset value is independent of the resolution selected in module M1.

## 7.15 Module M8: Error handling procedures

**Module ID: 1008**

**Submodule ID: 1**

### Description

The module makes parameters available to handle any errors should they occur.

If the device experiences a temporary disruption in the measurement value/velocity calculation (e.g. plausibility error caused by light beam interruption), the laser measurement system transmits the last valid measurement value for a configured length of time xx.

If the configured time is exceeded, the error display or the error measurement value output is activated.

Tab. 7.18: Parameter

Parameter	Rel. addr.	Data type	Data length	Min. value	Max. value	Default	Unit
Position value in the case of failure	0.0	Bit	1	0	1	1	
Reserve B0	0.1	Bit	1	0	0	0	
Suppress position status	0.2	Bit	1	0	1	1	
Error delay (position)	0.3	Bit	1	0	1	1	
Error delay time (position)	1.0	Unsigned16	1	100	1000	100	
Velocity value in the case of failure	3.0	Bit	1	0	1	1	
Reserve B3	3.1	Bit	1	0	0	0	
Suppress velocity status	3.2	Bit	1	0	1	1	
Error delay (velocity)	3.3	Bit	1	0	1	1	
Error delay time (velocity)	4.0	Unsigned16	1	200	1000	200	

### Input data

None

### Output data

None

### Position value in the case of failure

Specifies which position value is to be output in the event of an error after the position suppression time has elapsed.

0 = Last valid value

**1 = Zero**

### Reserve B0

No function. Always 0.

### Suppress position status

Specifies whether the PLB status bit is set immediately in the event of an error or if it is suppressed for the configured position suppression time.

0 = OFF

**1 = ON**

**Error delay (position)**

Specifies whether, in the event of an error, the position value immediately outputs the value of the "Position value in the case of failure" parameter or the last valid position value for the configured error delay time.

0 = OFF

**1 = ON**

**Error delay time (position)**

Error delay time for the position value in ms

Errors which occur are suppressed for the configured time. If no valid position value can be ascertained during the configured time, the last valid position value is output. If the error persists after the time elapses, the value stored in the "Position value in the case of failure" parameter is output.

**Velocity value in the case of failure**

Specifies which velocity is to be output in the event of an error after the velocity suppression time has elapsed.

0 = Last valid value

**1 = Zero**

**Reserve B3**

No function. Always 0.

**Suppress velocity status**

Specifies whether the PLB status bit is set immediately in the event of an error or if it is suppressed for the configured velocity suppression time.

0 = OFF

**1 = ON**

Error delay (velocity)

Specifies in the event of an error whether the velocity immediately outputs the value of the "Velocity in the case of failure" parameter or outputs the last valid velocity for the duration of the configured "error delay time".

0 = OFF

**1 = ON**

**Error delay time (velocity)**

Error delay time for the velocity value in ms

Errors which occur are suppressed for the configured time. If no valid velocity value can be ascertained during the configured time, the last valid velocity value is output. If the error persists after the time elapses, the value stored in the "Velocity value in the case of failure" parameter is output.

## 7.16 Module M9: Velocity

**Module ID: 1009**

**Submodule ID: 1**

### Description

Outputs the current velocity with the configured resolution. The unit (metric or inch) is set in module M1 (position value) and also applies to the velocity. If module M1 is not configured, the Module M9 operates with the default unit (metric).

The sign of the velocity is dependent on the counting direction in module M1.

In the default setting, a positive velocity is output when the reflector moves away from the AMS 148i. When the reflector moves toward the AMS 148i, negative velocities are output. If the "negative" counting direction is configured in module M1, the velocity sign is reversed.

Measurement value preparation averages all velocity values calculated during the selected period (averaging) to yield a velocity output value.

Tab. 7.19: Parameter

Parameter	Rel. addr.	Data type	Data length	Min. value	Max. value	Default	Unit
Velocity resolution	0.0	Bit	3	1	4	1	
Averaging	0.3	Bit	3	0	5	3	

Tab. 7.20: Input data

Input	Rel. addr.	Data type	Data length	Min. value	Max. value	Default	Unit
Velocity	0.0	Integer32	1	-999999	999999	0	

### Output data

None

### Velocity resolution

The parameter specifies the resolution for the velocity value.

**001 = 1: 1**

010 = 2: 10

011 = 3: 100

100 = 4: 1000

The resolution has no effect on velocity limit values.

### Averaging

The parameter specifies the response time (averaging time) of the calculated velocity values.

You can find the device's averaging time in the technical data.

000 = 0: 1 cycle time

001 = 1: 2 cycle time

010 = 2: 4 cycle time

**011 = 3: 8 cycle time**

100 = 4: 16 cycle time

101 = 5: 32 cycle time

### Velocity

Displays the current velocity value in mm/s or in/100/s, scaled according to the "Velocity resolution" parameter.

## 7.17 Module M10: Velocity limit value 1

Module ID: 1010

Submodule ID: 1

### Description

Velocity limit value 1 compares the current velocity with the value specified in the "Velocity limit value 1" parameter. This occurs in the configured range, which is defined by range start and range end. Depending on the selected parameter for the switching type, if the value exceeds or falls below the defined limit values, the limit value status is set in the module M12 velocity status, and, if configured, the hardware output is set accordingly via modules M3 and M4.

<b>NOTICE</b>	
	<p>If range start and range end are identical, velocity monitoring is active over the entire traversing range.</p> <p>If a direction-dependent limit value check is activated via the Direction selection parameter, the values of range start and range end also define the direction. The check is always performed from range start to range end. For example, if the range start is "5500" and the range end is "5000", the direction-dependent check is only performed in the direction from "5500" to "5000". The limit value is not active in the opposite direction.</p> <p>If the check is independent of direction, the order of range start and range end is irrelevant.</p>

Tab. 7.21: Parameter

Parameter	Rel. addr.	Data type	Data length	Min. value	Max. value	Default	Unit
Switching type	0.0	Bit	1	0	1	0	
Direction selection	0.1	Bit	1	0	1	0	
Velocity limit value 1	1.0	Unsigned16	1	0	20000	0	
Velocity hysteresis 1	3.0	Unsigned16	1	0	20000	100	
Limit value 1 range start	5.0	Integer32	1	-999999	999999	0	
Limit value 1 range end	9.0	Integer32	1	-999999	999999	0	

### Input data

None

### Output data

None

### Switching type

Condition for the "Velocity limit value 1" signal, which applies to the output (module M3 and/or M4) and the status bit (module M12).

**0 = Above limit value**

1 = Below limit value

### Direction selection

Selection of the direction-dependent or direction-independent limit value check.

**0 = Direction independent**

1 = Direction dependent

**Velocity limit value 1**

The threshold value in mm/s or in/100/s is compared with the current velocity.

**Velocity hysteresis 1**

Hysteresis value in mm/s or in/100/s to prevent signal bouncing.

**Limit value 1 range start**

Range start value in mm or in/100.

The velocity limit value is monitored beginning at this position.

**Limit value 1 range end**

Range end value in mm or in/100.

The velocity limit value is monitored up to this position.

### 7.18 Module M11: Velocity limit value 2

Module ID: 1011

Submodule ID: 1

#### Description

Velocity limit value 2 compares the current velocity with the value specified in the “Velocity limit value 2” parameter. This occurs in the configured range, which is defined by range start and range end. Depending on the selected parameter for the switching type, if the value exceeds or falls below the defined limit values, the limit value status is set in the module M12 velocity status, and, if configured, the hardware output is set accordingly via modules M3 and M4.

<b>NOTICE</b>	
	<p>If range start and range end are identical, velocity monitoring is active over the entire traversing range.</p> <p>If a direction-dependent limit value check is activated via the Direction selection parameter, the values of range start and range end also define the direction. The check is always performed from range start to range end. For example, if the range start is "5500" and the range end is "5000", the direction-dependent check is only performed in the direction from "5500" to "5000". The limit value is not active in the opposite direction.</p> <p>If the check is independent of direction, the order of range start and range end is irrelevant.</p>

Tab. 7.22: Parameter

Parameter	Rel. addr.	Data type	Data length	Min. value	Max. value	Default	Unit
Switching type	0.0	Bit	1	0	1	0	
Direction selection	0.1	Bit	1	0	1	0	
Velocity limit value 2	1.0	Unsigned16	1	0	20000	0	
Velocity hysteresis 2	3.0	Unsigned16	1	0	20000	100	
Limit value 2 range start	5.0	Integer32	1	-999999	999999	0	
Limit value 2 range end	9.0	Integer32	1	-999999	999999	0	

#### Input data

None

#### Output data

None

#### Switching type

Condition for the “Velocity limit value 2” signal, which applies to the output (module M3 and/or M4) and the status bit (module M12).

**0 = Above limit value**

1 = Below limit value

#### Direction selection

Selection of the direction-dependent or direction-independent limit value check.

**0 = Direction independent**

1 = Direction dependent

**Velocity limit value 2**

The threshold value in mm/s or in/100/s is compared with the current velocity.

**Velocity hysteresis 2**

Hysteresis value in mm/s or in/100/s to prevent signal bouncing.

**Limit value 2 range start**

Range start value in mm or in/100.

The velocity limit value is monitored beginning at this position.

**Limit value 2 range end**

Range end value in mm or in/100.

The velocity limit value is monitored up to this position.

**7.19 Module M12: Velocity status****Module ID: 1012****Submodule ID: 1****Description**

This module supplies various velocity measurement status information to the PROFINET master.

**Parameter**

None

Tab. 7.23: Input data

Input	Rel. addr.	Data type	Data length	Min. value	Max. value	Default	Unit
Velocity limit value comparison 1	0.3	Bit	1	0	1	0	
Velocity limit value comparison 2	0.4	Bit	1	0	1	0	
Velocity measurement error	1.0	Bit	1	0	1	0	
Movement status	1.1	Bit	1	0	1	0	
Direction of movement	1.2	Bit	1	0	1	0	
Velocity limit value status 1	1.3	Bit	1	0	1	0	
Velocity limit value status 2	1.4	Bit	1	0	1	0	

**Output data**

None

**Velocity limit value comparison 1**

Signals whether the current velocity is compared with this limit value.

**0 = Comparison not active**

1 = Comparison active

**Velocity limit value comparison 2**

Signals whether the current velocity is compared with this limit value.

**0 = Comparison not active**

1 = Comparison active

**Velocity measurement error**

Signals that no valid velocity could be ascertained.

**0 = OK**

1 = Error

**Movement status**

Signals whether a movement > 0.1 m/s is currently being detected.

**0 = No movement**

1 = Movement

**Direction of movement**

When the movement status is activated, this bit indicates the direction.

**0 = Positive direction**

1 = Negative direction

**Velocity limit value status 1**

Signals that limit value 1 has been exceeded.

**0 = Limit value observed**

1 = Limit value violated

**Velocity limit value status 2**

Signals that limit value 2 has been exceeded.

**0 = Limit value observed**

1 = Limit value violated

## 7.20 Module M13: Miscellaneous

**Module ID: 1013**

**Submodule ID: 1**

### Description

General operating parameters such as display language, display lighting and display contrast, password and heating control are set in this module.

Tab. 7.24: Parameter

Parameter	Rel. addr.	Data type	Data length	Min. value	Max. value	Default	Unit
Language selection	0.0	Bit	3	1	5	1	
Display lighting	0.3	Bit	1	0	1	1	
Password protection	0.4	Bit	1	0	1	0	
Password	1.0	Unsigned16	1	0	999	0	
Heating control	3.0	Bit	1	0	1	0	

### Input data

None

### Output data

None

### Language selection

Language selection for the display. A language preselected via the display is overwritten by this parameter.

**001 = 1: English**

010 = 2: German

011 = 3: Italian

100 = 4: Spanish

101 = 5: French

### Display lighting

OLED display backlight turns off after 10 mins or always on.

0 = Always on

**1 = Off after 10 min**

### Password protection

Password protection on/off

**0 = Off**

1 = On

### Password

Specifies the password.

Password protection must be enabled.

### Heating control

Defines a switch-on/switch-off range for the heating control. The extended switch-on/switch-off range for heating may provide a remedy in the event of condensation problems.

Due to the limited heating capacity, it cannot be guaranteed that no condensation will form on the optics in the extended switch-on/switch-off range.

This parameter is available as standard, but functions only for devices with integrated heating (AMS 148i ... H).

**0 = Standard:  $T_{amb} < 10^{\circ}\text{C}$ : Heating on,  $T_{amb} > 15^{\circ}\text{C}$ : Heating off**

**1 = Extended:  $T_{amb} < 30^{\circ}\text{C}$ : Heating on,  $T_{amb} > 35^{\circ}\text{C}$ : Heating off**

**7.21 Module M14: Condition monitoring****Module ID: 1014****Submodule ID: 1****Description**

This module displays the device's condition data, such as temperature and operating time.

**Parameter**

None

Tab. 7.25: Input data

Input	Rel. addr.	Data type	Data length	Min. value	Max. value	Default	Unit
Operating time	0.0	Unsigned32	1	0	0	0	
Temperature	4.0	Integer16	1	-300	1200	0	

**Output data**

None

**Operating time**

This signal indicates the device's operating time in seconds.



**Temperature**

This signal outputs the internal temperature in tenths of a degree Celsius.

## 8 Starting up the device – webConfig tool

With the Leuze webConfig tool, a web-technology based, graphical user interface is available for AMS configuration and diagnosis.

The webConfig tool can be run on any Internet-ready PC. The webConfig tool uses HTTP as communication protocol and the client-side restriction to standard technologies (HTML, JavaScript and AJAX) that are supported by modern browsers.

<b>NOTICE</b>	
	<p><b>Configuration changes via the webConfig tool have no effect in PROFINET!</b></p> <p>↳ <b>Always</b> perform the basic configuration using the GSDML file (see chapter 7.1 "Basic configuration").</p> <p>In process operation, only the parameters in the PROFINET modules set via the GSDML file or the PROFINET default presets are in effect.</p> <p>If you switch the AMS to <i>Service</i> mode using the webConfig tool, the AMS will be disconnected from PROFINET. All parameters set via the GSDML file initially remain in effect.</p>
<b>NOTICE</b>	
	<p>The webConfig tool is offered in the following languages: German, English, Chinese</p>

### 8.1 System requirements

Tab. 8.1: System requirements for the webConfig tool

Monitor	Min. resolution: 1280 x 800 pixels or higher
Internet browser	<p>Recommended is a current version of:</p> <ul style="list-style-type: none"> <li>• Mozilla Firefox</li> <li>• Google Chrome</li> <li>• Microsoft Edge</li> </ul> <p>Note: Other Internet browsers are possible but have not been tested with the current device firmware.</p>

<b>NOTICE</b>	
	<p>↳ Regularly update the operating system and the Internet browser.</p> <p>↳ Install the current Windows Service Packs.</p>

#### Clear browser history

The cache of the Internet browser is to be cleared if different device types or devices with different firmware were connected to the webConfig tool.

- ↳ Delete cookies and temporary Internet and website data from browser history before starting the web-Config tool.

## 8.2 Start webConfig tool

- ↪ Connect the supply voltage to the AMS.
- ↪ Connect the AMS service interface to the PC.  
The connection to the AMS service interface is made via the PC's RJ45 Ethernet interface. Use an Ethernet cable with a D-coded M12 connector and an RJ45 connector.  
An Ethernet adapter also allows you to use the USB interface on the PC. To do this, use a standard cable with a Type A USB connector and a D-coded M12 Ethernet connector.
- ↪ Start the webConfig tool using your PC's Internet browser with IP address: **http://192.168.60.101**. This is the Leuze standard service address for communication with absolute measuring systems.
- ⇒ The webConfig start page appears on your PC.

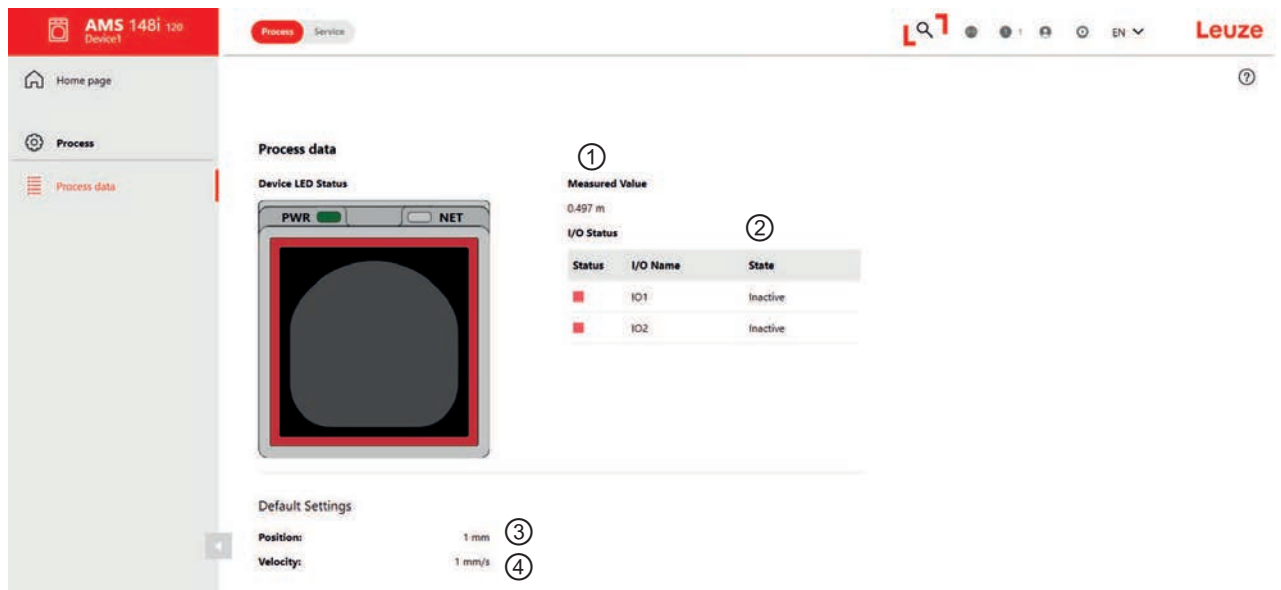

- 1 Current measurement value
- 2 I/O state 1/2
- 3 Position value resolution
- 4 Velocity value resolution

Fig. 8.1: webConfig tool start page

### NOTICE



The webConfig tool always starts in *Process* mode after startup.

## 8.3 Short description of the webConfig tool

The menus and dialog boxes of the webConfig tool are intuitive to operate and provide texts and tool tips. The start page of the webConfig tool displays the current process information.

### 8.3.1 Switching operating mode

You can use the webConfig tool to switch between the following operating modes:

#### Process

- The device is connected to the control or to the PC.
- Process communication with the control is active and position values are provided via the interfaces.
- The switching inputs/outputs are activated.
- Allows read-only access to the process data and diagnosis registers.

## Service

- The *Service* operating mode enables read and write access to all registers.
- The process communication to the control is interrupted and no position values are provided via the interfaces.
- The switching inputs/outputs are deactivated.

Located in the top left of every page of the webConfig tool is a software switch for changing the operating mode (Process – Service).

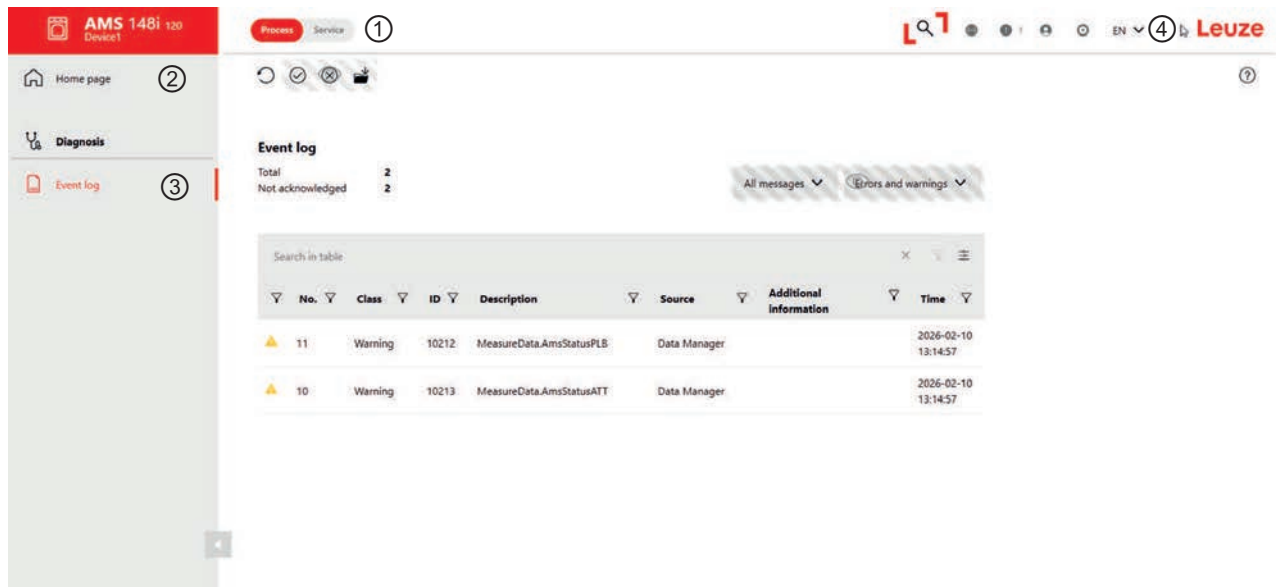

- 1 Switching between the process and service operating modes
- 2 Main menu
- 3 Diagnosis menu structure
- 4 Language switching

Fig. 8.2: webConfig tool overview

### 8.3.2 Menu overview

The [Home page] button displays the webConfig tool's menu overview.

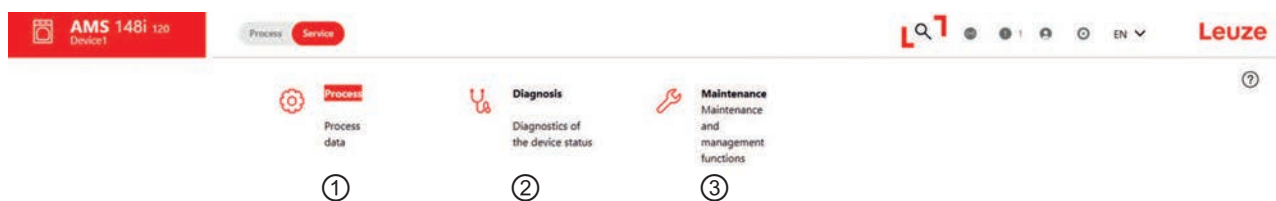

Fig. 8.3: webConfig menu overview

#### 1. Process

- Information on the current measurement value
- Information about switching inputs and outputs

#### 2. Diagnosis

- Event logging of info, warnings and errors

#### 3. Maintenance

- User management
- Backup/Restore
- Firmware update
- System clock

## 9 Care, maintenance and disposal

### Cleaning

If there is dust on the device or the warning message ATT is issued:

- ↪ Clean the device with a soft cloth; use a cleaning agent (commercially available glass cleaner) if necessary.
- ↪ Also check the reflector for possible contamination.

#### NOTICE



#### Do not use aggressive cleaning agents!

- ↪ Do not use aggressive cleaning agents such as thinner or acetone for cleaning the device. The use of such solvents can dull the reflector, the housing window and the display.

### Maintenance

The device does not normally require any maintenance by the operating company.

Repairs to the device must only be carried out by the manufacturer.

- ↪ For repairs, contact your responsible Leuze subsidiary or Leuze customer service (see chapter 11 "Service and support").

### Disposing

#### NOTICE



For disposal observe the applicable national regulations regarding electronic components.

## 10 Diagnostics and troubleshooting

### 10.1 Status messages

The status messages are written in a ring memory with 25 positions. The ring memory is organized according to the FIFO principle. No separate activation is necessary for storing the status messages. Power OFF clears the ring memory.

Example:



Fig. 10.1: Example of status message

#### Structure of status messages

**n: Type/No./1**

n	Memory position in the ring memory
Type	Type of message: I = info, W = warning, E = error, F = severe system error
No.	Internal error detection
1	Frequency of the event (always "1" because no summation occurs)

Select the status messages in the ring memory using the [DOWN] button. Use the [ENTER] button to call up detailed information about the respective status message:

Type: type of message + internal counter

UID: Leuze-internal message encoding

ID: description of the message

Info: not currently used

Within the detailed information, press the [ENTER] button again to activate an action menu with the following functions:

- Acknowledge message
- Delete message
- Acknowledge all
- Delete all

### 10.2 LED indicators

Tab. 10.1: PWR LED

PWR indicator LED	Possible error cause	Measure
OFF	No supply voltage connected	Check supply voltage
	Hardware error	Send in device
Flashes red	Light beam interruption	Check alignment
	Plausibility error	Traverse rate > 10 m/s Additional measures see chapter 10.3 "Display messages"
Red, continuous light	Hardware error	For error description, see display, It may be necessary to send in the device

Tab. 10.2: NET LED

NET indicator LED	Possible error cause	Measure
OFF	No supply voltage connected	Check supply voltage
	Incorrect wiring	Check wiring
	PROFINET disabled	Enable the PROFINET interface on the AMS 148i

### 10.3 Display messages

Tab. 10.3: Warning messages in display

Display	Error no.	Possible error message	Measure
PLB (implausible measurement values)	10212	Laser beam interruption	Laser spot must always be incident on the reflector
		Laser spot outside of reflector	Traverse rate < 10 m/s?
		Measurement range for maximum distance exceeded	Restrict traversing path or select AMS with larger measurement range
		Velocity greater than 10 m/s	Reduce velocity
		Ambient temperature far outside permissible range (TMP display; PLB)	Provide cooling
ATT (insufficient received signal level)	10213	Reflector soiled	Clean reflector
		Glass lens of the AMS soiled	Clean glass lens
		Performance reduction due to snow, rain, fog, condensing vapor or heavily polluted air (oil mist, dust)	Optimize usage conditions
		Laser spot only partially on reflector	Check alignment
		Protective film on reflector	Remove protective film from reflector
TMP (operating temperature outside of specification)	10210	Ambient temperatures outside specified range	In cold temperatures, an AMS with heating may help. If temperatures are too high, provide cooling or change mounting location.
LSR (laser diode warning)	10211	Laser diode prefailure message	Send in device at next possible opportunity to have laser diode replaced. Have replacement device ready.
ERR (hardware error)	-	Indicates an uncorrectable error in the hardware	Send in device for repair

## 11 Service and support

### Service hotline

You can find the contact information for the hotline in your country on our website [www.leuze.com](http://www.leuze.com) under **Contact & Support**.

### Repair service and returns

Defective devices are repaired in our service centers competently and quickly. We offer you an extensive service packet to keep any system downtimes to a minimum. Our service center requires the following information:

- Your customer number
- Product description or part description
- Serial number or batch number
- Reason for requesting support together with a description

Please register the merchandise concerned. Simply register return of the merchandise on our website [www.leuze.com](http://www.leuze.com) under **Contact & Support > Repair Service & Returns**.

To ensure quick and easy processing of your request, we will send you a returns order with the returns address in digital form.

### What to do should servicing be required?

<b>NOTICE</b>	
	<p><b>Please use this chapter as a master copy should servicing be required!</b></p> <p>↪ Enter the contact information and fax this form together with your service order to the fax number given below.</p>

### Customer data (please complete)

Device type:	
Serial number:	
Firmware:	
Display messages	
Status of LEDs:	
Error description:	
Company:	
Contact person/department:	
Phone (direct dial):	
Fax:	
Street/No:	
ZIP code/City:	
Country:	

### Leuze Service fax number:

+49 7021 573-199

## 12 Technical data

### 12.1 Optical laser measurement system

Tab. 12.1: Characteristic parameters

MTTF	27 years (at 25 °C)
------	---------------------

Tab. 12.2: Measurement data



	AMS 148i 40	AMS 148i 120	AMS 148i 200
Measurement range	0.1 – 40 m	0.1 – 120 m	0.1 – 200 m
Accuracy	±2 mm	±2 mm	±3 mm
Reproducibility (1 sigma; typical values for standard filter types)	0.2 mm	0.2 mm	0.25 mm
Light spot diameter	≤ 40 mm	≤ 100 mm	≤ 160 mm
Output time	1 ms		
Response time (compatibility mode)	8 ms		
Resolution	Adjustable, see chapter 7 "Starting up – PROFINET interface"		
Temperature drift	≤ 1 mm/10 K		
Ambient temperature sensitivity	1 ppm/K		
Air pressure sensitivity	0.3 ppm/hPa		
Traverse rate	≤ 10 m/s		
Boot time	20 s		
Operating temperature for devices with integrated heating	-30 °C – +60 °C		

Tab. 12.3: Optical data

Light source	Laser, red
Laser class	2 (acc. to IEC 60825-1:2014)
Wavelength	660 nm
Impulse duration	≤ 0.8 μs
Max. output power (peak)	4 mW

Tab. 12.4: Electrical data

Supply voltage	18 – 30 V DC
Current consumption	≤ 250 mA/24 V DC
Heater current consumption	≤ 500 mA/24 V DC
VDE protection class	III

 <b>CAUTION</b>	
	<p><b>UL applications!</b></p> <p>For UL applications, the device must be powered by a PS2 in accordance with EN / IEC / UL 62368-1 or an LPS in accordance with EN / IEC / UL 60950-1 or NEC Class 2.</p>

<b>NOTICE</b>	
	<p><b>Protective Extra Low Voltage (PELV)!</b></p> <p>The device is designed in accordance with protection class III for supply with PELV (Protective Extra-Low Voltage).</p>

Tab. 12.5: PROFINET interface

Interface type	PROFINET-RT with integrated switch for BUS IN and BUS OUT
Protocol	PROFINET RT communication
Conformance class	B
Switching inputs/switching outputs	<ul style="list-style-type: none"> <li>• Quantity</li> <li>• Input</li> <li>• Output</li> </ul>
	<ul style="list-style-type: none"> <li>• 2, configurable</li> <li>• Protected against polarity reversal</li> <li>• Max. 60 mA, short-circuit proof</li> </ul>

Tab. 12.6: Controls and indicators

Operational controls	Membrane keyboard, 2 buttons
Display	LC display, 128x32 pixels
LED	2 LEDs, two-colored

Tab. 12.7: Mechanical data

Housing	Diecast aluminum
Optics cover	Glass
Weight	Approx. 1 kg
Degree of protection	IP65 (acc. to EN 60529) with screwed-on M12 connectors or mounted caps

Tab. 12.8: Environmental data

Ambient temperature	
<ul style="list-style-type: none"> <li>• Operation</li> <li>• Storage</li> </ul>	<p>-5°C – +60°C</p> <p>-30°C – +70°C</p>
Relative air humidity	Max. 90%, non-condensing
Vibration	IEC 60068-2-6, test Fc
Shock	IEC 60068-2-27, test Ea
Noise	IEC 60068-2-64
Electromagnetic compatibility	<p>EN 61000-6-2</p> <p>EN 61000-6-4</p>

## 12.2 Reflective tapes

### 12.2.1 Self-adhesive reflective tape

Tab. 12.9: Technical data of self-adhesive reflective tape

Feature	Reflective tape 200x200-S	Reflective tape 500x500-S	Reflective tape 914x914-S	REF 4- A-150x150	REF 4- A-300x300
Part no.	50104361	50104362	50108988	50141015	50141014
Film size	200x200 mm	500x500 mm	914x914 mm	150x150 mm	300x300 mm
Recommended application temperature for adhesive tape	+5 °C ... +25 °C				
Temperature resistance, affixed	-40 °C ... +80 °C				

### 12.2.2 Reflective tape on carrier plate

Tab. 12.10: Technical data of reflective tape on carrier plate

Feature	Reflective tape 200x200-M	Reflective tape 500x500-M	Reflective tape 914x914-M
Part no.	50104364	50104365	50104366
Film size	200x200 mm	500x500 mm	914x914 mm
Outer dimensions of carrier plate	250x250 mm	550x550 mm	964x964 mm
Weight	0.8 kg	4 kg	25 kg

### 12.2.3 Reflective tape with heating

Tab. 12.11: Technical data of reflective tape with heating

Feature	Reflective tape 200x200-H	Reflective tape 500x500-H	Reflective tape 914x914-H
Part no.	50115020	50115021	50115022
Voltage supply	230 V AC		
Power	100 W	600 W	1800 W
Current consumption	~ 0.5 A	~ 3 A	~ 8 A
Length of supply line	2 m		
Size of reflective tape	200x200 mm	500x500 mm	914x914 mm
Outer dimensions of base material	250x250 mm	550x550 mm	964x964 mm
Weight	0.5 kg	4.4 kg	13.7 kg
Temperature control	Controlled heating with the following switch-on and switch-off temperatures, measured at the reflector surface		
Switch-on temperature	~ 5 °C		
Switch-off temperature	~ 20 °C		
Operating temperature	-30°C – +70°C		
Storage temperature	-40°C – +80°C		
Air humidity	Max. 90%, non-condensing		

### 12.3 Dimensioned drawings

#### Optical laser measurement system AMS 148i

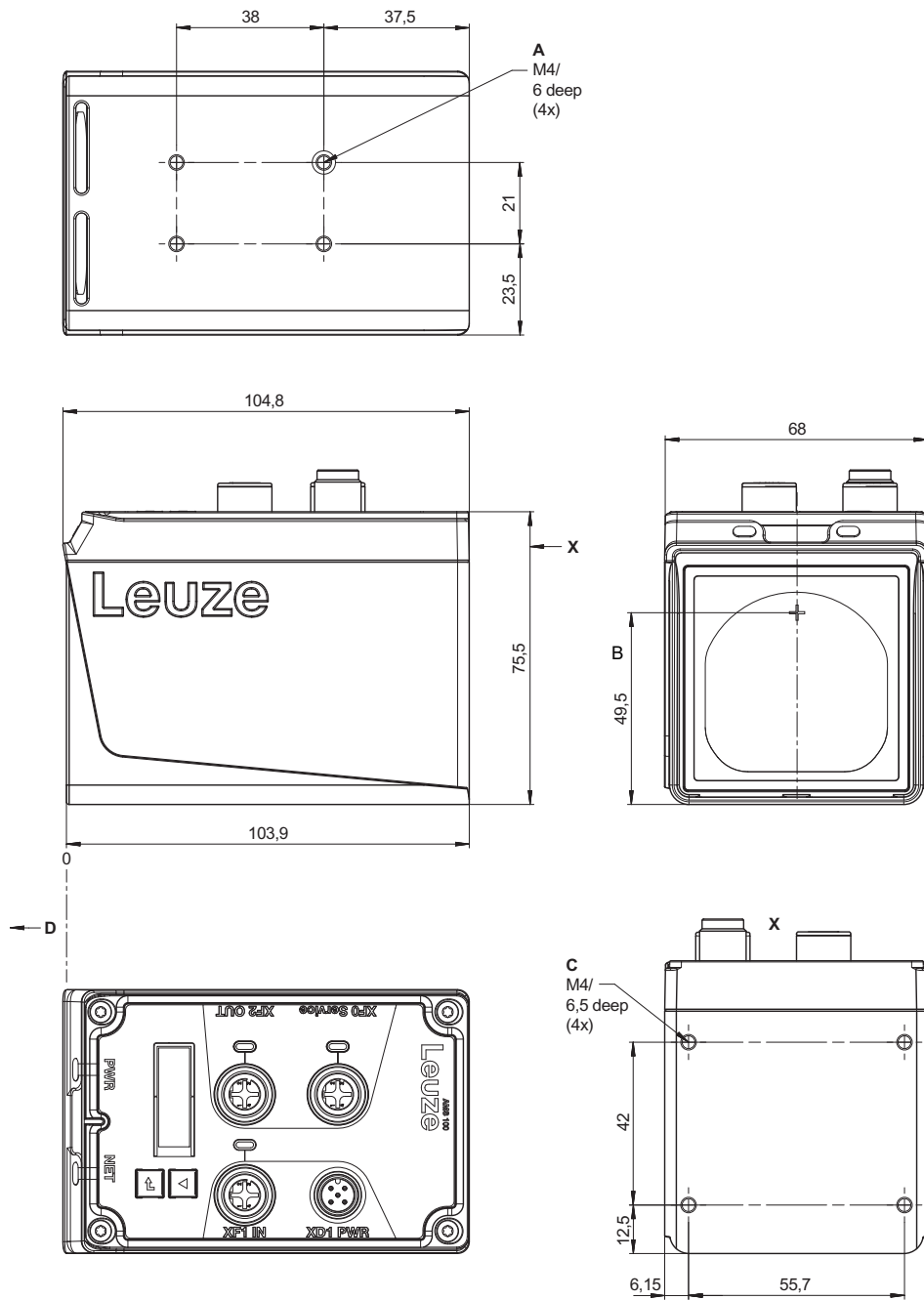

All dimensions in mm

- A Mounting variant: Bottom of the device
- B Optical axis
- C Mounting options for the BTA alignment unit
- D Zero point of the distance to be measured

Fig. 12.1: Optical laser measurement system AMS 148i

**Alignment unit BTA 0100M or BTA 0100 M.5**

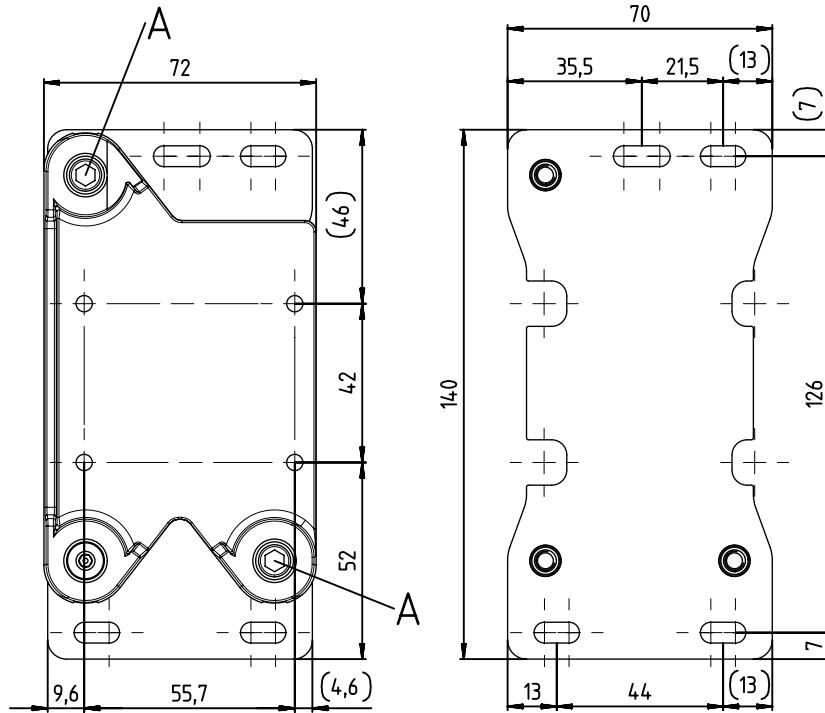

All dimensions in mm

A Adjustment screws with hexagon socket WAF4

Fig. 12.2: Alignment unit BTA 0100M (aluminum/steel) or BTA 0100 M.5 (stainless steel)

**Adapter plate BT 0100M**

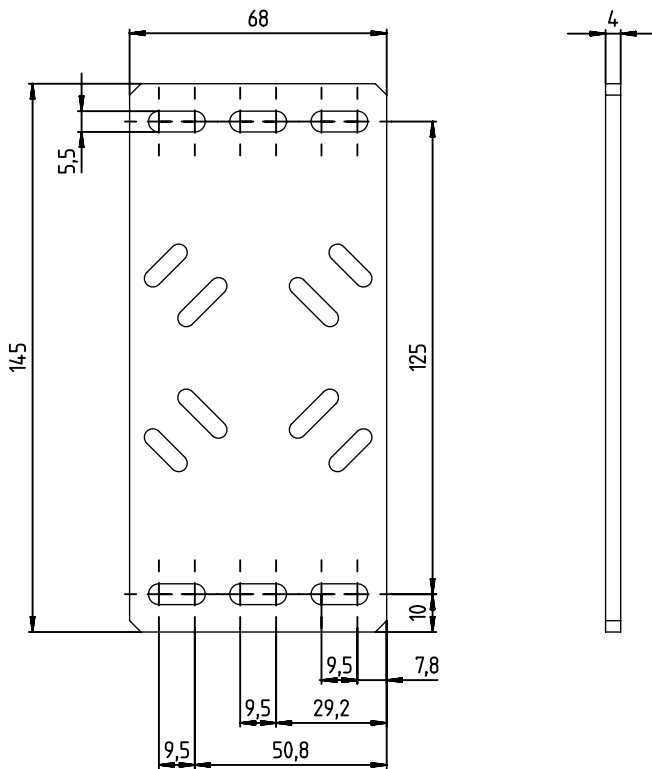

All dimensions in mm

Fig. 12.3: Mounting device BT 0100M for mounting without an alignment unit

Floor holder BT 0100M-F

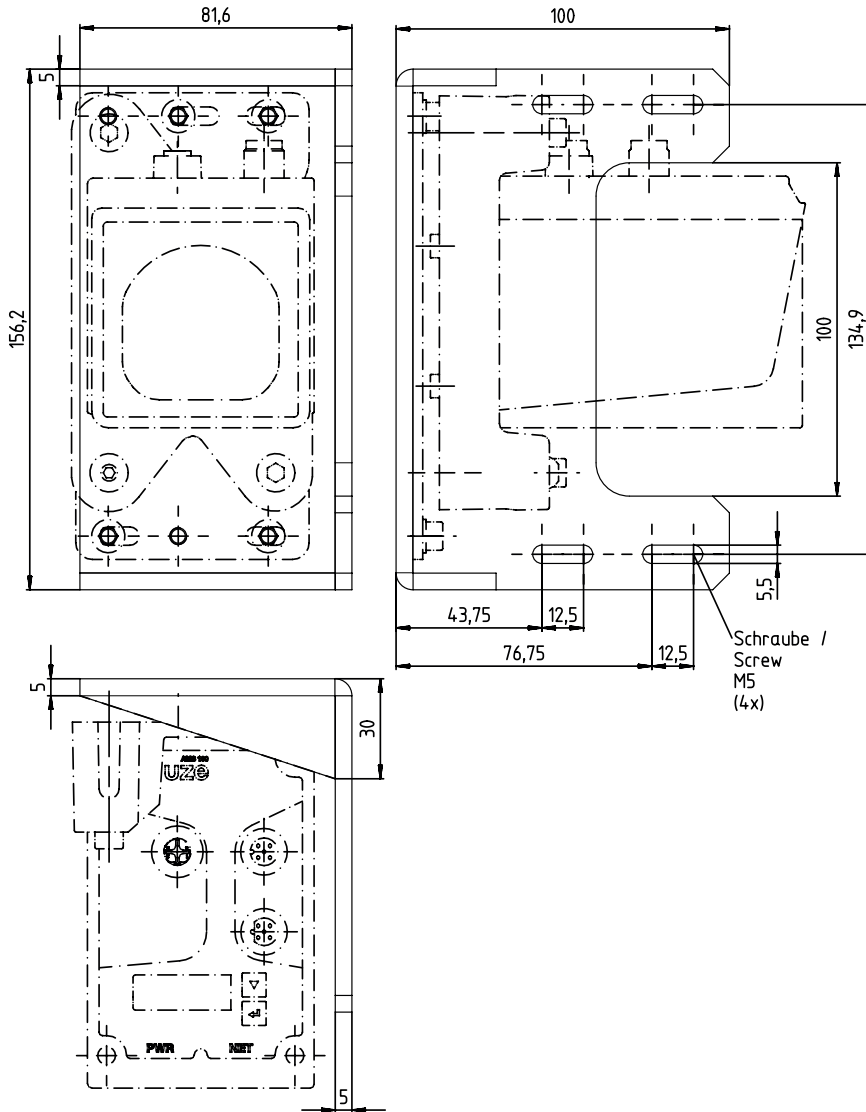

All dimensions in mm

Fig. 12.4: Mounting device BT 0100M-F for floor mounting or horizontal surfaces

Deflector unit US AMS 02

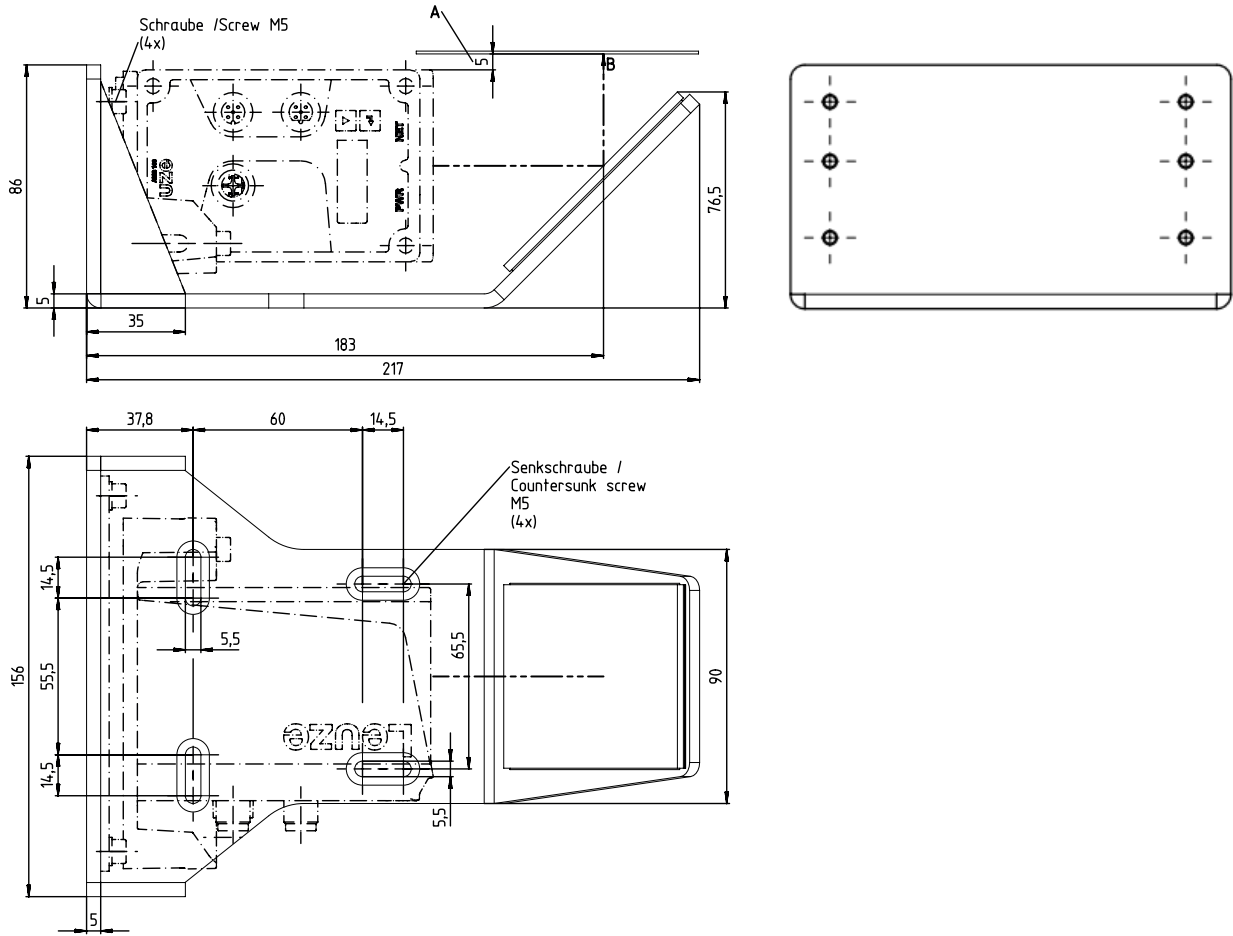

All dimensions in mm

- A Minimum distance from the reflector
- B Optical axis

Fig. 12.5: Deflecting mirror US AMS 02 – For use with AMS 148i xxx BTA

Deflector unit US 1 OMS

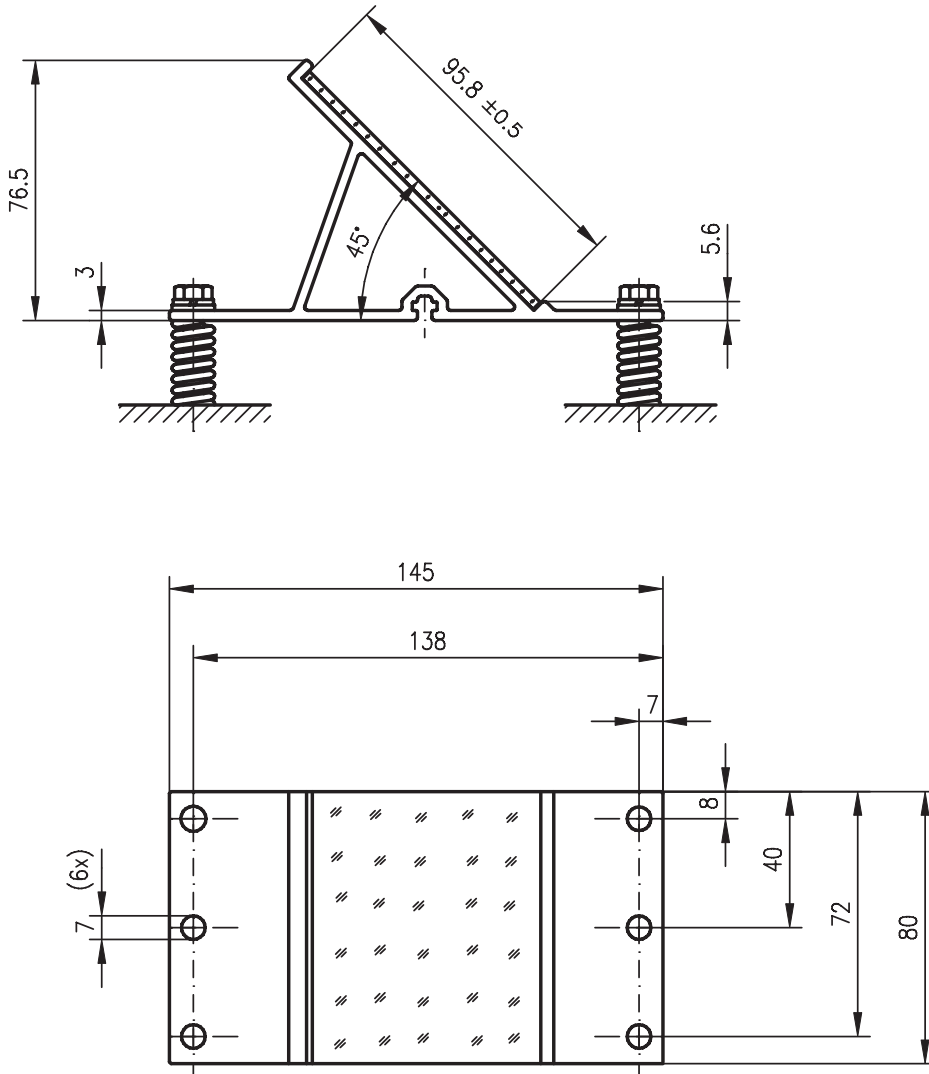

All dimensions in mm

Fig. 12.6: Deflecting mirror US 1 OMS without mounting bracket for simple 90° deflection of laser beam

Reflector

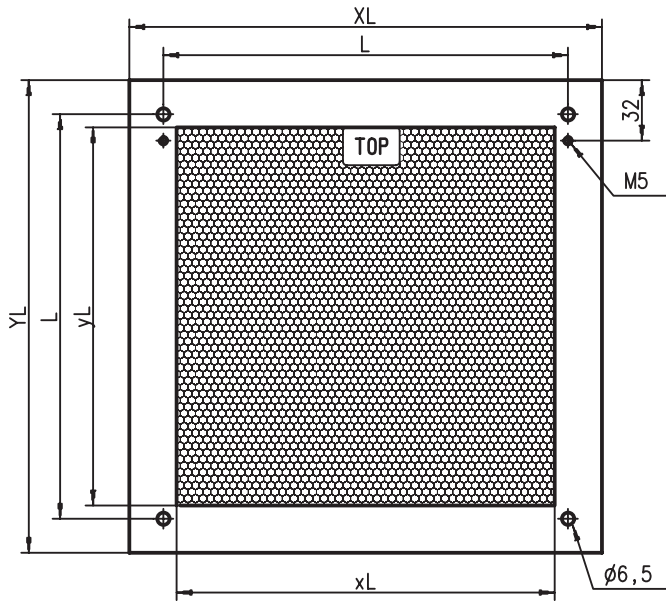

All dimensions in mm

Fig. 12.7: Reflective tape ...-M on carrier plate

Tab. 12.12: Dimensions of reflective tape on carrier plate

Article	Reflective tape [mm]		Reflector plate [mm]		
	xL	yL	XL	YL	L
Reflective tape 200x200-M	200	200	250	250	214
Reflective tape 500x500-M	500	500	550	550	514
Reflective tape 914x914-M	914	914	964	964	928

Heated reflector

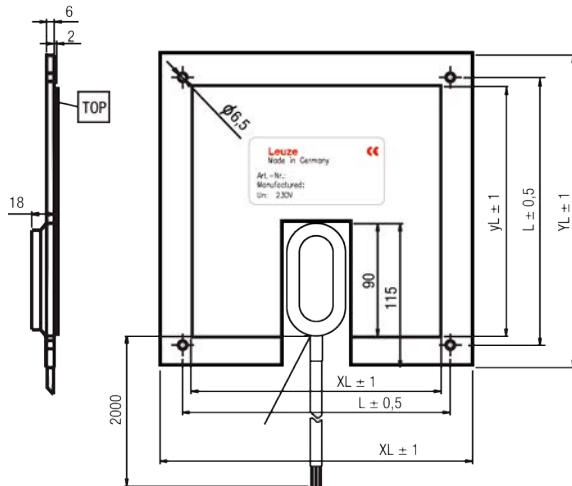

All dimensions in mm

Fig. 12.8: Reflective tape ...-H

Tab. 12.13: Dimensions of heated reflectors

Article	Reflective tape [mm]		Insulated carrier plate [mm]		
	xL	yL	XL	YL	L
Reflective tape 200x200-H	200	200	250	250	214
Reflective tape 500x500-H	500	500	550	550	514
Reflective tape 914x914-H	914	914	964	964	928

## 13 Order guide and accessories

### 13.1 Part number code

#### AMS 1xxi yyy zzz

AMS	Optical laser measurement system (absolute measurement system)
1	Series: AMS 100i
xx	Interface: 07: SSI 08: Ethernet TCP/IP 48: PROFINET
i	i: Integrated fieldbus technology
yyy	Operating range: 40: max. operating range in m 120: max. operating range in m 200: max. operating range in m
zzz	Mounting accessories: see chapter 13.3 "Accessories – Mounting"

#### NOTICE



A list with all available device types can be found on the Leuze website [www.leuze.com](http://www.leuze.com).

## 13.2 AMS 148i type overview

Tab. 13.1: AMS 148i

Type designation	Description	Part no.
AMS 148i 40	Optical laser measurement system, 40 m operating range, PROFINET interface	50154103
AMS 148i 120	Optical laser measurement system, 120 m operating range, PROFINET interface	50154104
AMS 148i 200	Optical laser measurement system, 200 m operating range, PROFINET interface	50155738
AMS 148i 40 BTA	Optical laser measurement system, 40 m operating range, PROFINET interface, pre-assembled alignment unit	50154100
AMS 148i 120 BTA	Optical laser measurement system, 120 m operating range, PROFINET interface, pre-assembled alignment unit	50154099
AMS 148i 200 BTA	Optical laser measurement system, 200 m operating range, PROFINET interface, pre-assembled alignment unit	50155737
AMS 148i 40 H	Optical laser measurement system, 40 m operating range, PROFINET interface, integrated heating	50154105
AMS 148i 120 H	Optical laser measurement system, 120 m operating range, PROFINET interface, integrated heating	50154106
AMS 148i 200 H	Optical laser measurement system, 200 m operating range, PROFINET interface, integrated heating	50155739
AMS 148i 40 BTA H	Optical laser measurement system, 40 m operating range, PROFINET interface, pre-assembled alignment unit, integrated heating	50154101
AMS 148i 120 BTA H	Optical laser measurement system, 120 m operating range, PROFINET interface, pre-assembled alignment unit, integrated heating	50154102
AMS 148i 200 BTA H	Optical laser measurement system, 200 m operating range, PROFINET interface, pre-assembled alignment unit, integrated heating	50155740

## 13.3 Accessories – Mounting

Tab. 13.2: Mounting

Type designation	Description	Part no.
US AMS 02	Deflecting mirror for 90° deflection of the laser beam, for use with AMS 148i xxx BTA	50144969
US 1 OMS	Deflector unit without mounting bracket for simple 90° deflection of laser beam	50035630
BTA 0100 M	Alignment unit	50144385
BTA 0100 M.5	Stainless steel alignment unit	50151594
BT 0100 M	Adapter plate for mounting without alignment unit	50144968
BT 0100M-F	Mounting plate for floor assembly and/or horizontal surfaces	50144970

### 13.4 Accessories – Reflective tapes

Tab. 13.3: Overview of reflective tape types

Type designation	Description	Part no.
REF 4-A-150x150	Self-adhesive reflective tape, 150 x 150 mm	50141015
Reflective tape 200x200-S	Self-adhesive reflective tape, 200 x 200 mm	50104361
REF 4-A-300x300	Self-adhesive reflective tape, 300 x 300 mm	50141014
Reflective tape 500x500-S	Self-adhesive reflective tape, 500 x 500 mm	50104362
Reflective tape 914x914-S	Self-adhesive reflective tape, 914 x 914 mm	50108988
Reflective tape 200x200-M	Reflective tape on carrier plate, 200 x 200 mm	50104364
Reflective tape 500x500-M	Reflective tape on carrier plate, 500 x 500 mm	50104365
Reflective tape 914x914-M	Reflective tape on carrier plate, 914 x 914 mm	50104366
Reflective tape 200x200-H	Reflective tape on heated carrier plate, 200 x 200 mm	50115020
Reflective tape 500x500-H	Reflective tape on heated carrier plate, 500 x 500 mm	50115021
Reflective tape 914x914-H	Reflective tape on heated carrier plate, 914 x 914 mm	50115022

### 13.5 Accessories – connection technology

Tab. 13.4: Connection cables

Type designation	Description	Part no.
KS ET-M12-4A-P7-050	Connection cable, length 5 m, shielded	50135074
KS ET-M12-4A-P7-100	Connection cable, length 10 m, shielded	50135075
KS ET-M12-4A-P7-150	Connection cable, length 15 m, shielded	50135076
KS ET-M12-4A-P7-300	Connection cable, length 30 m, shielded	50135077
KD U-M12-5A-V1-020	Connection cable, length 2 m, unshielded	50132077
KD U-M12-5A-V1-050	Connection cable, length 5 m, unshielded	50132079
KD U-M12-5A-V1-100	Connection cable, length 10 m, unshielded	50132080

## 14 EC Declaration of Conformity

The optical laser measurement systems of the AMS 100i series have been developed and manufactured in accordance with the applicable European standards and directives.

<b>NOTICE</b>	
	<p>You can download the EC Declaration of Conformity from the Leuze website.</p> <ul style="list-style-type: none"><li>↳ Call up the Leuze website: <a href="http://www.leuze.com">www.leuze.com</a>.</li><li>↳ Enter the type designation or part number of the device as the search term. The article number can be found on the name plate of the device under the entry "Part. No."</li><li>↳ The documents can be found on the product page for the device under the <i>Downloads</i> tab.</li></ul>

## 15 Licenses

The service interface can be accessed via a web browser using the IP address 192.168.60.101, either through the webConfig tool or after connecting an Ethernet cable.

↳ To do this, go to Settings and open the *Licensestab*.

The license texts for the software packages can then be selected via the drop-down menu.