

Technical data sheet RFID read/write device

Part no.: 50040499

RFM 62 SL 200

Contents

- Technical data
- Dimensioned drawings
- Electrical connection
- Operation and display
- Notes
- Further information



For illustration purposes only



Technical data

Basic data

Series	RFM
Working frequency	13.56 MHz

Functions

Functions	Configurable operating modes
	I/O
	LED indicator
	Reading gate control

Read data

Reading/writing range, max.	400 mm
Transponder, readable	ICodeSLI
	Infinion MyD
	TagIT HFI

Electrical data

Performance data

Supply voltage U_B	12 ... 30 V, DC
Power consumption, max.	2 W
Memory access	Read/Write
Transmission speed	4,000 Bd

Inputs

Number of digital switching inputs	1 Piece(s)
------------------------------------	------------

Outputs

Number of digital switching outputs	1 Piece(s)
-------------------------------------	------------

Interface

Type	RS 232
RS 232	
Function	Process

Connection

Number of connections	1 Piece(s)
Connection 1	
Function	Data interface
	Signal IN
	Signal OUT
	Voltage supply
Type of connection	Cable with socket connectors (10+6)
Cable length	1,000 mm

Mechanical data

Design	Cubic
Dimension (W x H x L)	298 mm x 34 mm x 298 mm
Housing material	Plastic
Net weight	1,978 g
Housing color	Black
Type of fastening	Through-hole mounting

Environmental data

Ambient temperature, operation	-25 ... 65 °C
Ambient temperature, storage	-40 ... 70 °C
Relative humidity (non-condensing)	5 ... 90 %

Certifications

Degree of protection	IP 65
----------------------	-------

Classification

Customs tariff number	84719000
ECLASS 5.1.4	27280401
ECLASS 8.0	27280401
ECLASS 9.0	27280401
ECLASS 10.0	27280401
ECLASS 11.0	27280401
ECLASS 12.0	27280401
ECLASS 13.0	27280401
ECLASS 14.0	27280401
ECLASS 15.0	27280401
ECLASS 16.0	27280401
ETIM 5.0	EC001825
ETIM 6.0	EC002998
ETIM 7.0	EC002998
ETIM 8.0	EC002998
ETIM 9.0	EC002998
ETIM 10.0	EC002998
UNSPSC 26.08	43211710

Dimensioned drawings

All dimensions in millimeters

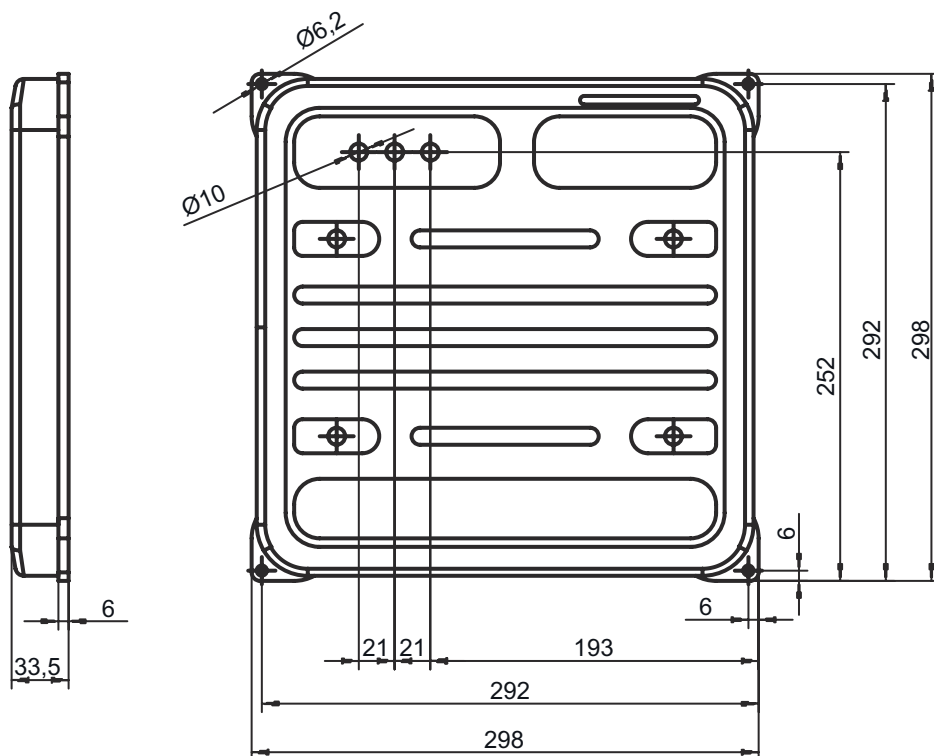

Electrical connection

Connection 1

Function	Data interface Signal IN Signal OUT Voltage supply
Type of connection	Cable with socket connectors (10+6)
Cable length	1,000 mm

Pin	Pin assignment	Conductor color
1	n.c.	White-brown
2	n.c.	White-red
3	n.c.	White-orange
4	n.c.	White-yellow
5	n.c.	White-green
6	SWOUT 1	White-black
7	GND	Brown
8	n.c.	Red
9	n.c.	Orange
10	RxD	Yellow



Electrical connection

Pin	Pin assignment	Conductor color
11	TxD	Green
12	n.c.	Blue
13	SWIN 1	Violet
14	VIN	Gray
15	GNDIN	White
16	Shield	Shield

Operation and display

LED	Display	Meaning
1	Yellow, continuous light	Operational readiness
2	Red, continuous light	Reading gate active
3	Green, flashing	Reading successful

Notes

 Observe intended use!	
	<ul style="list-style-type: none"> ⌘ This product is not a safety sensor and is not intended as personnel protection. ⌘ The product may only be put into operation by competent persons. ⌘ Only use the product in accordance with its intended use.

Further information

- Under certain circumstances, metal in the reading field reduces the operating range considerably.
- Antenna calibration is to be performed after mounting. The calibration process optimally adapts the device to environment at the installation location and enables the maximum operating range for data transmission. See the operating instructions for further information.