

Diffuse reflection sensor

HT53C / HT53CS / HT53CXL

HT55C / HT55CS / HT55CXL



1

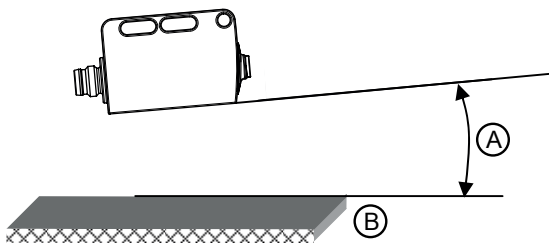

2

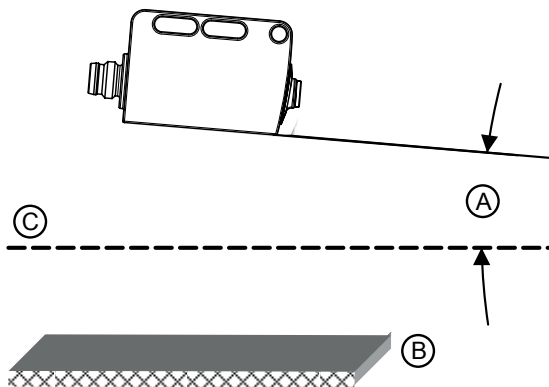

Application notes

Detection of glossy surfaces within the operating range

When detecting glossy surfaces (e.g. metals), the light beam should not hit the object surface at a right angle. A slight inclination is enough to detect the object reliably. The following applies: the smaller the range, the greater the angle of inclination (approx. 5° to 7°).

1

- A Slight inclination $5^\circ \dots 7^\circ$
- B Glossy object surface within the operating range

Avoiding interference from glossy surfaces in the background

If a glossy surface is in the background (distance larger than maximum range), reflections may cause interfering signals. They may be avoided by mounting the device at a slight inclination (see figure).

NOTICE



It is imperative to note the task and the associated inclination of the sensor of approx. $5^\circ \dots 7^\circ$.

2

- A Slight inclination $5^\circ \dots 7^\circ$
- B Glossy surface in the background
- C Maximum range
 - Only move objects in from the right or left side. Avoid moving in objects from the connector side or operating side.
 - Outside of the operating range, the sensor operates as an energetic diffuse reflection sensor. Light objects can still be reliably detected up to the maximum range.
 - The sensors are equipped with effective measures for the maximum avoidance of mutual interference should they be mounted opposite one another. Opposite mounting of multiple sensors of the same type must absolutely be avoided.