

Original operating instructions

MSI-RM2B

Safety Relays



© 2022

Leuze electronic GmbH + Co. KG

In der Braike 1

D-73277 Owen / Germany

Phone: +49 7021 573-0

Fax: +49 7021 573-199

<http://www.leuze.com>

info@leuze.de

1	About this document.	2
1.1	Used symbols and signal words	2
1.2	Checklists	2
2	Safety	3
2.1	Intended use and foreseeable misuse	3
2.1.1	Intended use	3
2.1.2	Foreseeable misuse	4
2.2	Competent persons	4
2.3	Responsibility for safety	4
2.4	Exemption of liability	5
3	Device description	6
3.1	System overview	7
3.2	Display elements	7
4	Functions	8
5	Applications	9
6	Mounting	10
7	Electrical connection	11
7.1	Terminal assignments	11
7.2	Circuit diagram examples	12
8	Starting up the device.	13
8.1	Switching on	13
9	Testing	14
9.1	Before the initial start-up and following modifications	14
9.1.1	Checklist – initial start-up	14
9.2	To be performed periodically by a competent person	15
9.3	To be performed daily by the operating personnel	16
9.3.1	Check list – daily or at change of shift	16
10	Maintenance	17
11	Disposing	18
12	Service and support	19
13	Technical data	20
13.1	General specifications	20
13.2	Interference emission	21
13.3	Dimensions	21
14	Order guide	23

1 About this document

1.1 Used symbols and signal words

Table 1.1: Warning symbols and signal words

	Symbol indicating dangers to persons
NOTE	Signal word for property damage Indicates dangers that may result in property damage if the measures for danger avoidance are not followed.
CAUTION	Signal word for minor injuries Indicates dangers that may result in minor injury if the measures for danger avoidance are not followed.
WARNING	Signal word for serious injury Indicates dangers that may result in severe or fatal injury if the measures for danger avoidance are not followed.
DANGER	Signal word for life-threatening danger Indicates dangers with which serious or fatal injury is imminent if the measures for danger avoidance are not followed.

Table 1.2: Other symbols



	Symbol for tips Text passages with this symbol provide you with further information.
	Symbol for action steps Text passages with this symbol instruct you to perform actions.

Table 1.3: Terms and abbreviations

AOPD	Active Optoelectronic Protective Device Active Opto-electronic Protective Device
EDM	External Device Monitoring
OSSD	Output Signal Switching Device
SSD	Secondary Switching Device
RES	Start/ RE start interlock
PFH ₀	Probability of a dangerous failure per hour Probability of dangerous Failure per Hour
MTTF _d	Mean time to dangerous failure (Mean Time To dangerous Failure)
PL	Performance Level

1.2 Checklists

The checklists (see chapter 9 "Testing") serve as a reference for the machine manufacturer or supplier. They replace neither testing of the complete machine or system prior to the initial start-up nor their periodic testing by a competent person. The checklists contain minimum testing requirements. Depending on the application, other tests may be necessary.

2 Safety

Before using the safety relay, a risk assessment must be performed according to valid standards (e.g. EN ISO 12100, ISO 13849-1, EN/IEC 61508, EN/IEC 62061). The result of the risk assessment determines the required safety level of the safety relay (see table 13.1). For mounting, operating and testing, this document as well as all applicable national and international standards, regulations, rules and directives must be observed. Relevant and supplied documents must be observed and handed to the affected personnel.

☞ Before working with the safety relay, completely read and understand the documents applicable to your task.

In particular, the following national and international legal regulations apply for the start-up, technical inspections and work with safety relays:

- Machinery directive 2006/42/EC
- Low voltage directive 2014/35/EU
- Electromagnetic compatibility 2014/30/EU
- Use of work equipment directive 2009/104/EC
- OSHA 1910 Subpart 0
- Safety regulations
- Accident-prevention regulations and safety rules
- Ordinance on Industrial Safety and Health and employment protection act
- Product safety law (Produktsicherheitsgesetz)

NOTE	
	For safety-related information you may also contact local authorities (e.g., industrial inspectorate, employer's liability insurance association, labor inspectorate, occupational safety and health authority).

2.1 Intended use and foreseeable misuse

⚠ DANGER	
	<p>Electrically live systems pose a risk of electric shock!</p> <p>☞ During all conversions, maintenance work and inspections, make certain that the voltage supply is interrupted and protected against being restarted again.</p> <p>☞ Only have work on the electrical system and electronics performed by a competent person.</p>

2.1.1 Intended use

⚠ WARNING	
	<p>A running machine may result in serious injury!</p> <p>☞ Make certain that the safety relay is correctly connected and that the protective function of the protective device is ensured.</p> <p>☞ Make certain that, during all conversions, maintenance work and inspections, the system is securely shut down and protected against being restarted.</p>

Only if the safety relay is correctly connected and correctly started up is the protective function of the protective device ensured. To prevent misuse and resulting dangers, the following must be observed:

- These operating instructions are included in the documentation of the system on which the protective device is mounted and are available to the operating personnel at all times.
- The safety relay is used as a safety relay in combination with safety sensors or other safety relays for safeguarding danger zones or points of operation in machines and systems.
- The safety relay must only be used after it has been selected in accordance with the respectively applicable instructions and relevant standards, rules and regulations regarding labor protection and safety at work, and after it has been installed, connected, checked and commissioned by a **competent person**.
- The safety relay must only be connected and commissioned in accordance with its specifications (technical data, environmental conditions, etc.).
- The "Reset" acknowledgment button for unlocking the start/restart interlock must be located outside of the danger zone.
- The entire danger zone must be visible from the installation site of the acknowledgment button.
- The safety relay must be selected so that its safety-related capability meets or exceeds the required Performance Level PL ascertained in the risk assessment (see table 13.1).
- The machine or system control must be electrically influenceable so that a switch command sent by the safety relay results in the immediate shutdown of the dangerous movement.
- The construction of the safety relay must not be altered. When manipulating the safety relay, the protective function is no longer guaranteed. Manipulating the safety relay also voids all warranty claims against the manufacturer of the safety relay.
- The safety relay must be tested regularly by a competent person (see chapter 9 "Testing").
- The safety relay must be exchanged after a maximum of 20 years. Repairs or the exchange of wear parts do not extend the mission time.
- The safety relay does not have a safety category or performance level of its own. When used as intended, it can, however, satisfy the prerequisites for achieving the safety category and Performance Level that corresponds to the connected safety sensor or safety relay.
- The connected safety sensors or safety relays must be equipped with OSSDs in cross-connection- and short-circuit-monitored design (EDM). The contactor monitoring function must check the closing of the signal circuit before the OSSDs are switched on and the opening of the same after switch-on has occurred.

2.1.2 Foreseeable misuse

Any use other than that defined under the "Approved purpose" or which goes beyond that use is considered improper use.

Alone, the safety relay is not a complete protective device. It is not suitable for use in the following cases:

- in explosive or easily flammable atmospheres.
- on machines or systems with long stopping times.

2.2 Competent persons

Prerequisites for competent persons:

- They have a suitable technical education.
- They know the rules and regulations for labor protection, safety at work and safety technology and can assess the safety of the machine.
- They know the instructions for the safety relay and the machine.
- They have been instructed by the responsible person on the mounting and operation of the machine and of the safety relay.

2.3 Responsibility for safety

Manufacturer and operating company must ensure that the machine and implemented safety relay function properly and that all affected persons are adequately informed and trained.

The type and content of all imparted information must not lead to unsafe actions by users.

The manufacturer of the machine is responsible for:

- Safe machine construction.
- Safe implementation of the safety relay.
- Imparting all relevant information to the operating company.
- Adhering to all regulations and directives for the safe starting-up of the machine.

The operator of the machine is responsible for:

- Instructing the operating personnel.
- Maintaining the safe operation of the machine.
- Adhering to all regulations and directives for labor protection and safety at work.
- Regular testing by competent persons.

2.4 Exemption of liability

Leuze electronic GmbH + Co. KG is not liable in the following cases:

- Safety relay is not used as intended.
- Safety notices are not adhered to.
- Reasonably foreseeable misuse is not taken into account.
- Mounting and electrical connection are not properly performed.
- Proper function is not tested (see chapter 9 "Testing").
- Changes (e.g., constructional) are made to the safety relay.

3 Device description

The MSI-RM2B relay module is suitable for use as a two-channel sequential circuit for safe protective devices with 2 OSSDs and contactor monitoring (EDM).



Figure 3.1: MSI-RM2B with screw terminals



Figure 3.2: MSI-RM2B with spring-cage terminals

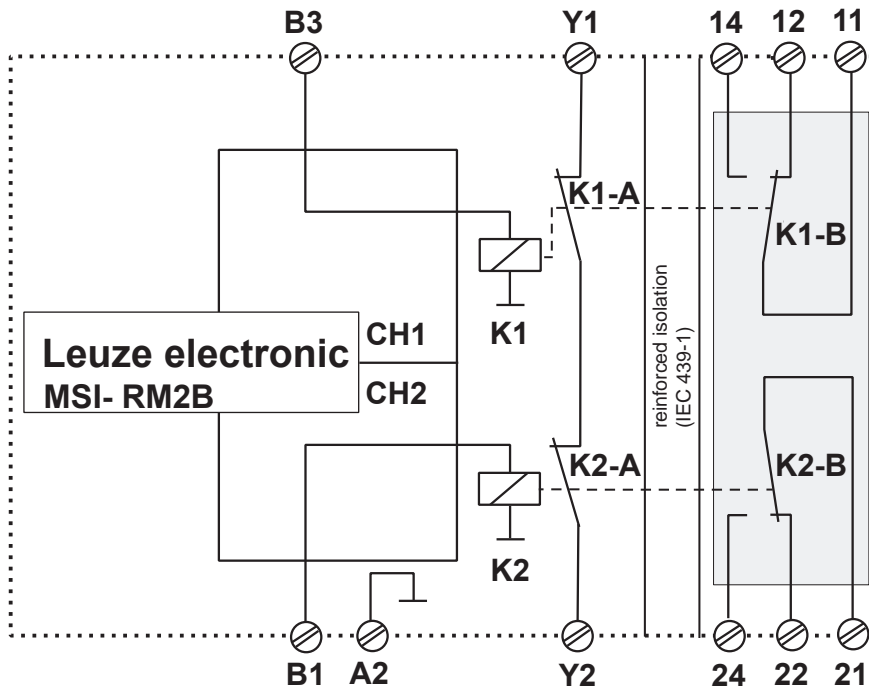

Figure 3.3: Internal circuit diagram of the MSI-RM2B

3.1 System overview

- NC contact as signal circuit for contactor monitoring (EDM)
- Monitoring of external contactors in the signal circuit
- 2 release circuits (changeovers)
- LED displays, K1 and K2
- Operating voltage 24 V DC
- Housing width 17.5 mm
- Removable connection terminal blocks (screw terminals, spring-cage terminals)

3.2 Display elements

The display elements of the safety relay simplify start-up and fault analysis.

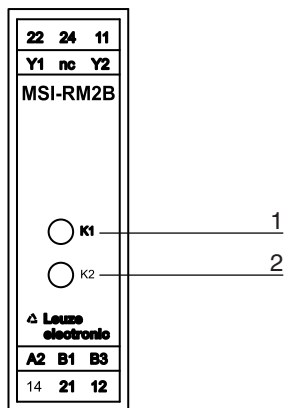

- 1 "K1" LED
- 2 "K2" LED

Figure 3.4: Display elements of the MSI-RM2B

Table 3.1: Meaning of the LEDs

LED	Color	Description
K1	Green	Relay K1 picked up
K2	Green	Relay K2 picked up

4 Functions

The MSI-RM2B safety relay converts the electronic safety-related switching outputs of safety sensors or safety relays into potential-free, positive-guided contacts with signaling path. It can be integrated into the contactor monitoring (EDM) via the signaling path.

5 Applications

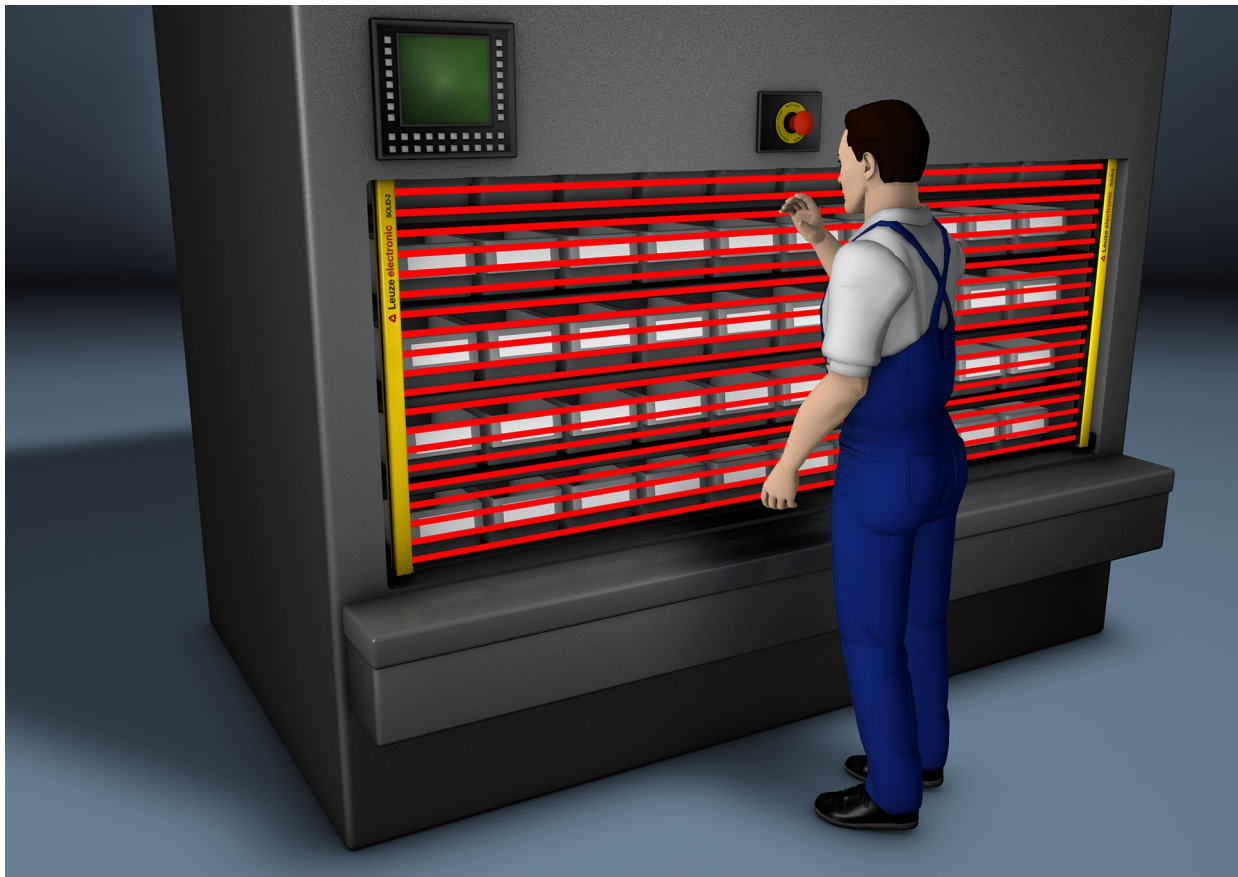



Figure 5.1: Guarding a paternoster shelf with MLC safety light curtain and MSI-RM2B relay module

6 Mounting

 WARNING	
	<p>Improper mounting may result in serious injury!</p> <p>The protective function of the safety relay is only ensured if appropriately and professionally mounted for the respective, intended area of application.</p> <ul style="list-style-type: none">↳ Only allow competent persons to install the safety relay.↳ Observe the relevant standards, regulations and these instructions.

The safety relay is intended for mounting on a DIN rail in the switch cabinet.



Prerequisites for mounting:

- Switch cabinet with appropriate degree of protection (at least IP54).
- Sufficient space on the DIN rail.

↳ Snap the safety relay onto the DIN rail.



The safety relay can be connected to the safety sensors.

7 Electrical connection

 DANGER	
	<p>Risk of death by electric shock!</p> <p>Depending on external wiring, dangerous voltages may be present at the switching outputs.</p> <p>↳ During all work at the electrical system or electronics, make certain that each voltage supply has been interrupted and protected against being restarted.</p>

The following must be observed for the current supply of the safety relay:

- Supply voltage 24 V DC $\pm 20\%$.
- Safe mains separation acc. to EN/IEC 60742 possible.
- A corresponding power supply unit handles interruptions of the supply voltage up to 10 ms in duration acc. to IEC 61496-1:2020.

 WARNING	
	<p>Improper electrical connection may result in serious injury!</p> <p>↳ Only allow competent persons to perform the electrical connection.</p> <p>↳ Make certain that supply and signal lines are laid separately from power lines.</p> <p>↳ Use appropriate spark extinction for contactors in the cabinet.</p> <p>↳ Observe the installation notices and operating instructions of the products that are to be connected via the safety relay (drive motors, brakes, etc.).</p>

The following conditions apply for the electrical connection:



- The safety relay is to be integrated in the control acc. to EN ISO 13849-1.
- No safety-relevant signals are switched via the message outputs.
- There are always two switching contacts integrated in the system switch-off circuit.
- Relay switching contacts are fused/protected externally according to their specifications.

Connecting the signal lines

For reliable and touch-safe contacts, isolate the connection ends as follows:

- Screw terminals: 7 mm
- Spring-cage terminals: 8 mm

7.1 Terminal assignments

 WARNING	
	<p>Selecting the wrong functions may result in serious accidents!</p> <p>↳ Always connect protective sensors to an external safety relay and activate the restart interlock.</p> <p>↳ For access guarding, make certain that the restart interlock cannot be unlocked from within the danger zone but that the danger zone can be viewed from the acknowledgment button (Reset).</p> <p>↳ Select the functions so that the safety relay is used as intended (see chapter 2.1 "Intended use and foreseeable misuse").</p>

Connected to the safety relay are 12 numbered terminals to which the cables for the various functions are connected.

Table 7.1: Terminal assignments

Terminal	MSI-RM2B
22	Relay contact 2 IN, NC
24	Relay contact 2 IN, NO
11	Relay contact 1 OUT
Y1	External device monitoring circuit (EDM)
n.c.	n.c.
Y2	External device monitoring circuit (EDM)
A2	0 V
B1	Sensor input channel 1, 24 V
B3	Sensor input channel 2, 24 V
14	Relay contact 1 IN, NO
21	Relay contact 2 OUT
12	Relay contact 1 IN, NC

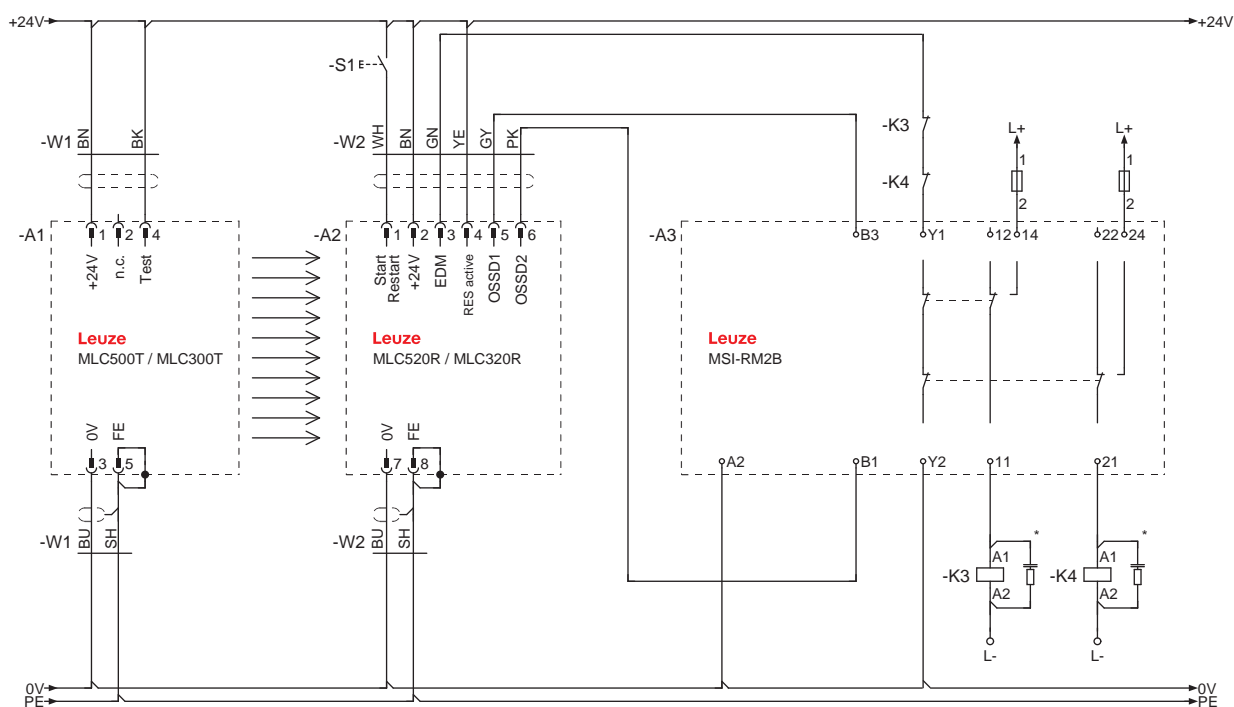

7.2 Circuit diagram examples



* Spark extinction circuit, suitable spark extinction provided

Figure 7.1: MSI-RM2B safety relay with MLC 500 / MLC 300 safety light curtain

8 Starting up the device

 WARNING	
	<p>Improper use of the safety relay may result in serious injury!</p> <ul style="list-style-type: none"> ↪ Make certain that the entire device and the integration of the optoelectronic protective device was inspected by competent and instructed persons. ↪ Make certain that a dangerous process can only be started while the safety devices are switched on.

Prerequisites:

- Protective sensors and safety relay were mounted and connected in accordance with the respective instructions.
- Operating personnel were instructed on proper use.
- Dangerous process was switched off and the system has been protected against being restarted again.

↪ During start-up, test the function of the safety relay (see chapter 9 "Testing").

8.1 Switching on

Requirements for the supply voltage (power supply unit):

- Safe mains separation is ensured (acc. to EN/IEC 60742).
- Changes and interruptions of the supply voltage are handled (acc. to IEC 61496-1:2020).
- The start/restart interlock function of the connected safety sensors or safety relays is activated.

↪ Switch on the current supply.

The safety relay is ready for use.

9 Testing

⚠ WARNING	
	<p>A running machine may result in serious injury!</p> <p>↪ Make certain that, during all conversions, maintenance work and inspections, the system is securely shut down and protected against being restarted.</p>

The safety relays must be exchanged after a maximum of 20 years.

- ↪ Always exchange the entire safety relay.
- ↪ For the tests, observe nationally applicable regulations.
- ↪ Document all tests in a comprehensible manner.

9.1 Before the initial start-up and following modifications

Acc. to IEC/TS 62046 and international regulations (e.g. EU directive 2009/104/EC), tests are to be performed by competent persons in the following situations:

- Prior to the initial start-up
- Following modifications to the machine
- After longer machine downtime
- After retrofitting or reconfiguring the safety device (safety relay and/or protective sensor)

⚠ WARNING	
	<p>Unpredictable machine behavior during initial start-up may result in serious injury!</p> <p>↪ Make certain that there are no people in the danger zone.</p>

- ↪ Test the effectiveness of the shutdown function in all operating modes of the machine acc. to the corresponding checklist (see chapter 9.1.1 "Checklist – initial start-up").
- ↪ Document all tests in a comprehensible manner and include the configuration of the safety relay along with the data for the safety and minimum distances in the documentation.
- ↪ Before they begin work, train the operating personnel on their respective tasks. The training is the responsibility of the operating company.
- ↪ Check whether the safety relay was correctly selected acc. to the locally applicable regulations and directives.
- ↪ Check whether the safety relay is operated acc. to the specified environmental conditions (see chapter 13 "Technical data").
- ↪ Make certain that the safety relay is protected against overcurrent.
- ↪ Perform a visual inspection for damage and test the electrical function (see chapter 9.2 "To be performed periodically by a competent person").

Minimum requirements for the power supply unit:

- Safe mains separation.
- Power-failure bridging for at least 10 ms.

Not until proper function of the optoelectronic safety device and the safety relay is ascertained may they be integrated in the control circuit of the system.

9.1.1 Checklist – initial start-up

Interval: once, prior to the initial start-up and following modification

Tester: competent person

Table 9.1: Checklist – initial start-up

Items on the check list	Yes	No
Were all safety directives and standards relevant to this machine type observed?		
Does the declaration of conformity of the machine include a listing of these documents?		
Does the safety relay satisfy the safety-related capability (PL, SIL, category) as required by the risk assessment?		
Circuit diagram: Are the safety-related switching outputs (OSSDs) integrated in the downstream machine control acc. to the required safety category?		
Are the switching elements (e.g. contactors) with positive-guided contacts that are controlled by the safety relay monitored by an external device monitoring circuit (EDM)?		
Does the electrical wiring match the circuit diagrams?		
Have the required protective measures against electrical shock been effectively implemented?		
Has the maximum stopping time of the machine been remeasured and recorded in the machine documents?		
Is the required safety distance (protective field to the next point of operation) maintained?		
Are all points of operation of the machine accessible only through the protective field? Are all additional protective devices (e.g. safety guards) correctly mounted and protected against tampering?		
Is the command device for triggering the start/restart interlock of the safety relay or the machine mounted in accordance with specifications?		
Are safety relay, connecting cable, plug, protection caps and command devices undamaged and free of any signs of manipulation?		
Has the effectiveness of the protective function been ensured for all operating modes of the machine by means of a function test?		
Is the start/restart button for resetting the safety relay mounted outside of the danger zone in accordance with specifications in such a way that it cannot be reached from within the danger zone? Can the entire danger zone be seen from the place at which the start/restart button is installed?		
Does the interruption of any given beam cause the dangerous movement to stop?		
When the AOPD is separated from its supply voltage, does the dangerous movement stop, and, after the supply voltage has been restored, is it necessary to actuate the start/restart button to reset the machine?		
Is the safety relay/protective sensor effective during the entire dangerous movement of the machine?		
Are the notices for daily testing of the safety sensor legible to the operating personnel and are they located in a highly visible location?		
Is the muting indicator visibly mounted on the entry/exit path?		

📁 Store this checklist with the machine documents.



9.2 To be performed periodically by a competent person



The reliable interaction of safety sensor, safety relay and machine must be periodically tested in order to detect changes to the machine or impermissible tampering with the safety sensor. Testing intervals are determined by nationally applicable regulations (recommendation acc. to IEC/TS 62046: 6 months).

- ↪ Have all tests performed by competent persons.
- ↪ Observe the nationally applicable regulations and the time periods specified therein.

9.3 To be performed daily by the operating personnel

The function of the safety relay must be checked daily or at change of shifts, and at each change of machine operating mode as specified in the corresponding checklist (see chapter 9.3.1 "Check list – daily or at change of shift") so that damages or unauthorized manipulations can be detected.

 WARNING	
	<p>Unpredictable machine behavior during the test may result in serious injury!</p> <p>↪ Make certain that there are no people in the danger zone.</p>

 WARNING	
	<p>Faults during the daily inspection may result in serious injury!</p> <p>If you answer one of the items on the check list (see table 9.2) with "no", the machine must no longer be operated.</p> <p>↪ Have the entire machine inspected by a competent person (see chapter 9.1 "Before the initial start-up and following modifications").</p>

- ↪ Stop the dangerous state.
- ↪ Check safety relay, transmitter, receiver and, if applicable, deflecting mirrors for damage or manipulation.
- ↪ Interrupt the light beam of the protective sensor from a position outside the danger zone and ensure that the machine cannot be started with an interrupted light beam.
- ↪ Start the machine.
- ↪ Ensure that the dangerous state is stopped as soon as a light beam is interrupted.

9.3.1 Check list – daily or at change of shift

Interval: daily or at shift change

Tester: authorized operating personnel or instructed person

Table 9.2: Check list – daily or at change of shift

Items on the check list	Yes	No
Are safety relay, protective sensor, connecting cables, plugs and command devices undamaged and free of any signs of manipulation?		
Are all points of operation at the machine accessible only through one or more protective fields of protective sensors?		
Are all additional protective devices mounted correctly (e.g., safety guard)?		
Does the start/restart interlock prevent the automatic start-up of the machine after the protective sensor/safety relay has been switched on or activated?		
↪ Interrupt a light beam of the protective sensor with a test object during operation. Is the dangerous movement shut down immediately?		

10 Maintenance

The safety relay is maintenance-free.

11 Disposing

↳ For disposal observe the applicable national regulations regarding electronic components.

12 Service and support

Service hotline

You can find the contact information for the hotline in your country on our website www.leuze.com under **Contact & Support**.

Repair service and returns

Defective devices are repaired in our service centers competently and quickly. We offer you an extensive service packet to keep any system downtimes to a minimum. Our service center requires the following information:

- Your customer number
- Product description or part description
- Serial number and batch number
- Reason for requesting support together with a description

Please register the merchandise concerned. Simply register return of the merchandise on our website www.leuze.com under **Contact & Support > Repair Service & Returns**.

To ensure quick and easy processing of your request, we will send you a returns order with the returns address in digital form.

What to do should servicing be required?

NOTE	
	<p>Please use this chapter as a master copy should servicing be required.</p> <p>✉ Enter the contact information and fax this form together with your service order to the fax number given below.</p>

Customer data (please complete)

Device type:	
Serial number:	
Firmware:	
Display messages	
Status of LEDs:	
Error description	
Company:	
Contact person/department:	
Phone (direct dial):	
Fax:	
Street / no.:	
ZIP code / City:	
Country:	

Leuze Service fax number:

+49 7021 573 - 199

13 Technical data

13.1 General specifications

Table 13.1: Safety-relevant technical data

Performance Level (PL) in accordance with EN ISO 13849-1: 2015	PL e
Category in acc. with EN ISO 13849-1:2015	Category 4
SIL in accordance with EN 61508	SIL 3
Type in accordance with IEC 61496-1:2020	Type 4
Mission time (T_M)	20 years
B10 _a at DC13 (inductive load)	10,000,000 switching cycles
B10 _a at AC15 (inductive load)	1,300,000 switching cycles
Mechanical life time	10,000,000 switching cycles

Table 13.2: Electrical data, degree of protection, environment

Supply voltage via OSSDs of the connected AOPD, B1 and B3	+24 V DC \pm 20 %
Power consumption via AOPD	2.5 W
Output contacts	2 changeovers, 1 NC contact (AgNi10 + 5 mm Au)
Switching capacity of the contacts acc. to EN/ IEC 60947-5-1	Y1 and Y2, DC-13: NC contact 24 V / 2 A 11, 12, 14, 21, 22, 24, DC-13: NO contact 24 V / 4 A, NC contact 24 V / 2 A 11, 12, 14, 21, 22, 24, AC-15: NO contact 230 V / 3 A, NC contact 230 V / 2 A
Max. continuous current per current path	3 A
External contact fuse protection per current path	5 A quick-action or 3.15 A delay-action
Control voltage/current on B1, B3	24 V DC / 32 mA, per path
Admissible input line resistance	50 Ω
Permissible wire gauge screw terminals	0.2 ... 2.5 mm ² (AWG 24-12)
Permissible wire gauge spring-cage terminals	0.2 ... 1.5 mm ² (AWG 24-16)
Maximum tightening torque	0.52 Nm
Air clearance and creepage distance	IEC/EN 60730, IEC/EN 60335
Ambient temperature, operation	0 ... +50 °C
Ambient temperature, storage	-25 ... +70 °C
Degree of protection	Housing IP 40 Terminals IP 20
Degree of contamination	2
Dimensions	see chapter 13.3
Weight	Approx. 120 g

Table 13.3: Time behavior

Pickup delay	20 ms
Regression delay, reaction time	10 ms

13.2 Interference emission

The device corresponds to CISPR 11/ EN 55011 Group 1 and Class B.

Groups

- Group 1: All devices that do not belong to Group 2 (lab equipment, devices for industrial process measurement and control)
- Group 2: All devices that intentionally generate HF energy for material processing / modification (microwave and induction ovens, electric welding equipment)

Classes

- Class A: Industrial systems in which the 230V supply network is provided by means of a separate transformer (from medium voltage)
- Class B: Commercial, industrial locations and residential areas that are supplied by the public 230V network (low-voltage network) or are connected to it

13.3 Dimensions

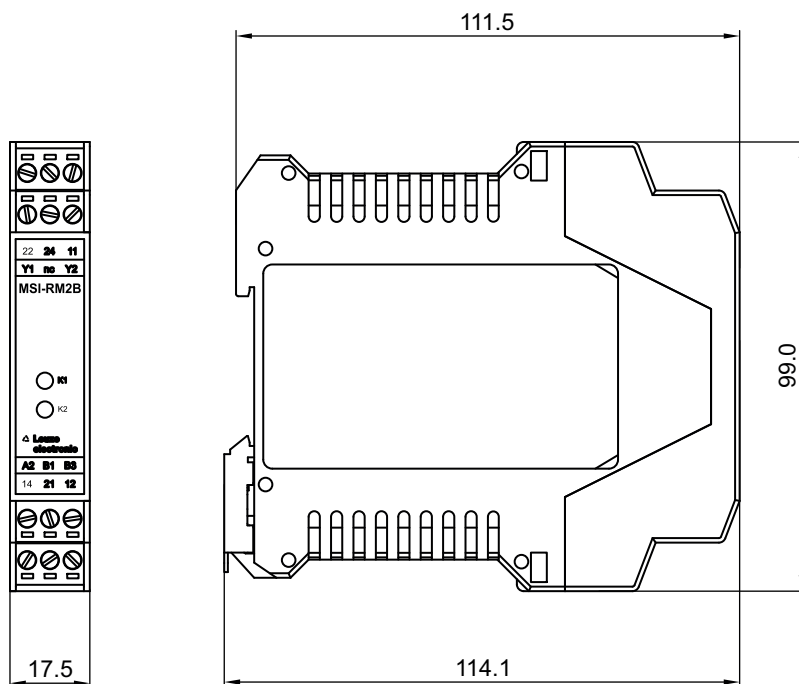

Figure 13.1: Dimensions MSI-RM2B-01

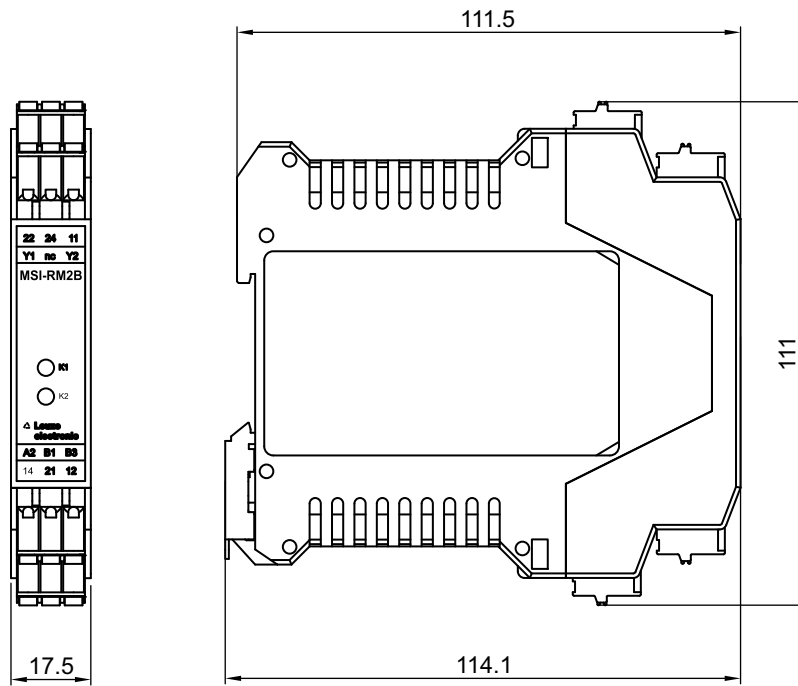

Figure 13.2: Dimensions MSI-RM2B-02

14 Order guide

Table 14.1: MSI-RM2H safety relays

Part no.	Article	Description
547954	MSI-RM2B-01	Safety relay, screw terminals
547955	MSI-RM2B-02	Safety relay, spring-cage terminals