

Leuze

Application Note Rotoscan RS4 – AS-Interface



This application Note is related to the following products:

Product	Article number
RS4-4/A1	580014
RS4-4M/A1	520042
RS4-4E/A1	520086
RS4-6E/A1	520046
RS4-6M/A1	520047

- There is **no** 1:1 replacement available.
- The new safe laserscanner (RSL) has only safe transistor outputs or Profisafe via Profinet!
- The new safe Laserscanner (RSL) has no motion functionality!

RSL with OSSD Outputs	RSL with Profinet	Range Protectionfield
RSL420-M*	RSL420P-M*	4,5 Meter
RSL420-L*	RSL420P-L*	6,25 Meter

*additional Connection Unit (CU) is necessary!

Mounting overview

OLD

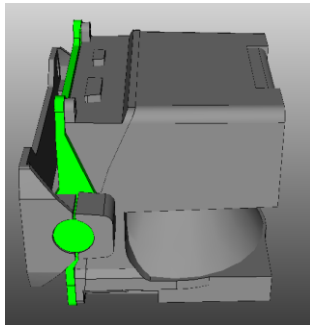

NEW

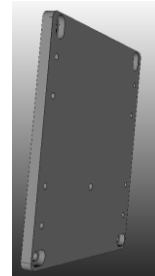

BT800MA



BTU804MA

Please mount the RSL upside down to reach same scanner height!

- Existing protection fields can be implemented in the new Scanner
 - => Only the .rs file is necessary
- Install Sensor Studio **and** Safety Device Collection from our Website:
 - => <https://www.leuze.com/en/INT/contact-support/downloads/software/>
- Implement the Protective fields here:



- Other Scanner functionalities must be configure separately!
- Please go through your old scanner configuration and note following things:
 - Automatic restart or restart prevention (incl. timing)
 - Protective field resolution
 - Protective field reaction time
- You will find every Setting on Sensor Studio again.

Article numbers

Product	Article number	Description
BT800MA	53800137	Adapter plate, RS4 drilling template
BTU804MA	53800136	compatible with RS4 mounting system

– For further article numbers please check the portfolio on our website:

<https://www.leuze.com/en/INT/products/safety/safety-products/safety-laser-scanners/>

Did you know...

...WE KEEP YOU SUPPLIED WORLDWIDE

On-Site service, repairs and device replacement service

- FAST ASSISTANCE DURING START-UP
- FAST HELP WORLDWIDE
- IN THE CASE OF EMERGENCY WE ARE AVAILABLE AROUND THE CLOCK

For emergencies, the Leuze electronic On-Call Service is available to you around the clock at +49 7021 573 – 0.



**For further support
please contact our
service hotline**



Technical Hotline

+49 7021 573 -110

Service.protect@leuze.com

Leuze electronic GmbH + Co. KG

www.leuze.com

