

## Technical data sheet

### Tower light

Part no.: 50155283

TL 105-32S-ROG-BZ-050-FX

#### Contents

- Technical data
- Dimensioned drawings
- Electrical connection
- Diagrams



For illustration purposes only



## Technical data

### Basic data

Series	TL 105
Type of signaling	Optical and acoustic

### Electrical data

#### Performance data

Supply voltage $U_B$	24 V, DC
Current consumption, max.	150 mA

#### Inputs

Number of digital switching inputs	4 Piece(s)
------------------------------------	------------

#### Switching inputs

Type	Digital switching input
Switching voltage high, min.	24 V
Switching voltage low, max.	0 V
Voltage type	DC

#### Digital switching input 1

Assignment	Connection 1, pin 1
Function	Light color (red) through actuation of pin

#### Digital switching input 2

Assignment	Connection 1, pin 2
Function	Acoustic signal (buzzer) via control of pin

#### Digital switching input 3

Assignment	Connection 1, pin 4
Function	Light color (green) through actuation of pin

#### Digital switching input 4

Assignment	Connection 1, pin 5
Function	Light color (orange) through actuation of pin

### Connection

Number of connections	1 Piece(s)
-----------------------	------------

#### Connection 1

Function	Light color via control of pins
	Signal IN
	Voltage supply
Type of connection	Open end
Cable length	500 mm
Number of conductors	5 -wire

### Mechanical data

Design	Cylindrical
Dimension ( $\varnothing$ x L)	50 mm x 190 mm
Thread pitch	1.5 mm
Housing material	Metal
Metal housing	Aluminum
Light area material	Plastic, Polycarbonate
Net weight	310 g
Housing color	Black
Type of fastening, at system	Screw type / vertical
Type of illuminant	LED/24V
Lens modules	3 pieces, ready-made
Signal image	Continuous light
Angle of radiation	-90~+90°
Sequence of the modules (ascending)	red, orange, green

### Environmental data

Ambient temperature, operation	-20 ... 45 °C
Ambient temperature, storage	-40 ... 70 °C

### Certifications

Degree of protection	IP 40
Protection class	III
Approvals	CE

### Acoustic data

Tone type	Continuous tone
Sound pressure	90 dB
Number of tones	1 Piece(s)

### Classification

Customs tariff number	85318070
ECLASS 5.1.4	27371230
ECLASS 8.0	27371230
ECLASS 9.0	27371230
ECLASS 10.0	27371230
ECLASS 11.0	27371230
ECLASS 12.0	27371230
ECLASS 13.0	27371230
ECLASS 14.0	27371230
ECLASS 15.0	27371230
ECLASS 16.0	27371230
ETIM 5.0	EC001042
ETIM 6.0	EC001042
ETIM 7.0	EC001042
ETIM 8.0	EC001042
ETIM 9.0	EC001042
ETIM 10.0	EC001042

# Dimensioned drawings

All dimensions in millimeters

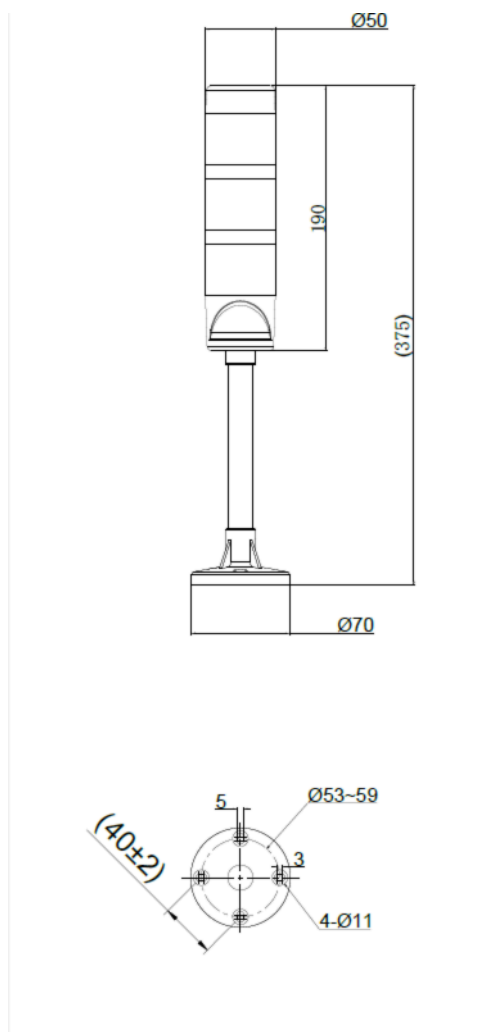

## Electrical connection

### Connection 1

Function	Light color via control of pins Signal IN Voltage supply
Type of connection	Open end
Selection of interface	PNP / NPN switchable
Cable length	500 mm
Cable color	Black
Number of conductors	5 -wire

### Conductor color

### Conductor assignment

Red	Red LED
Yellow	Yellow LED
Green	Green LED
Orange	Buzzer
Black	GND

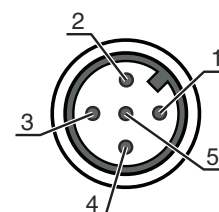

## Diagrams

### Interconnection cable

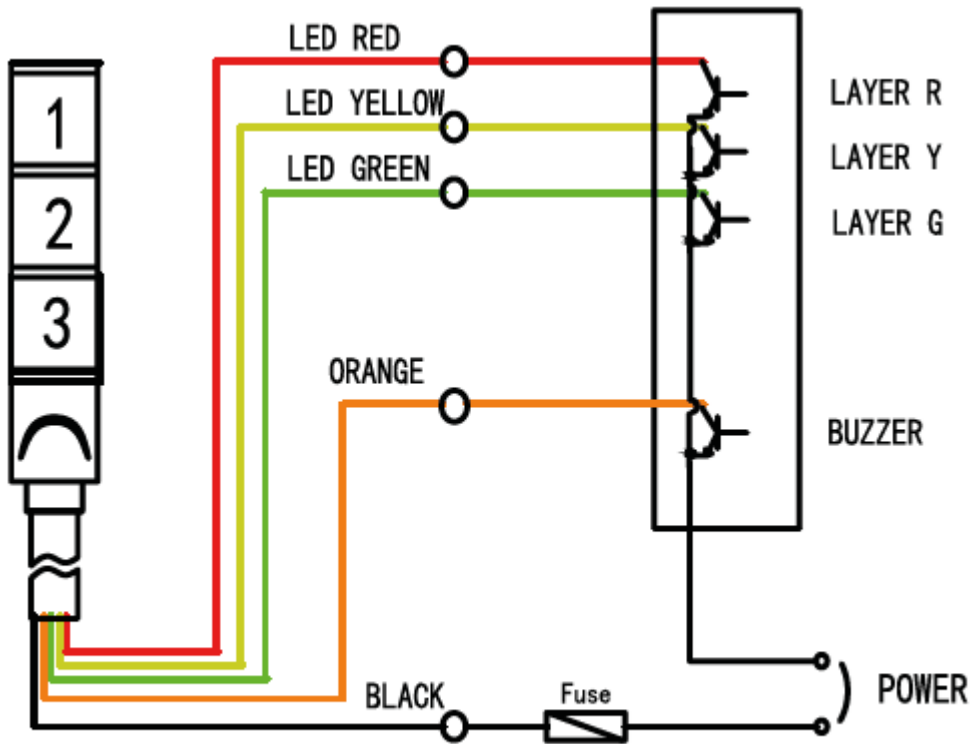

24V DC NPN&PNP